



**THE
64 GATES
TRANSIT
TRACKER
JOURNAL**

www.hdpsychologist.com



ABOUT THE AUTHOR

Hello and Welcome!

I created this guide because I was having a hard time keeping track of the Human Design Gates and my experiences with the transits of the Sun and Moon through the Gates, and I needed a place where I could put all of my notes for easy reference.

I hope this helps you too!

As a Manifesting Generator, I have a LOT of passions and interests, most of which I like to do at the same time!

I'm a psychologist, teacher, and Human Design coach and reader. I have several degrees in the fields of psychology and education and I've been experimenting with how to use Human Design in life, love, education, and business for five years now.

Nicole

Centers & Placement of the 64 Gates on the Human Design Bodygraph

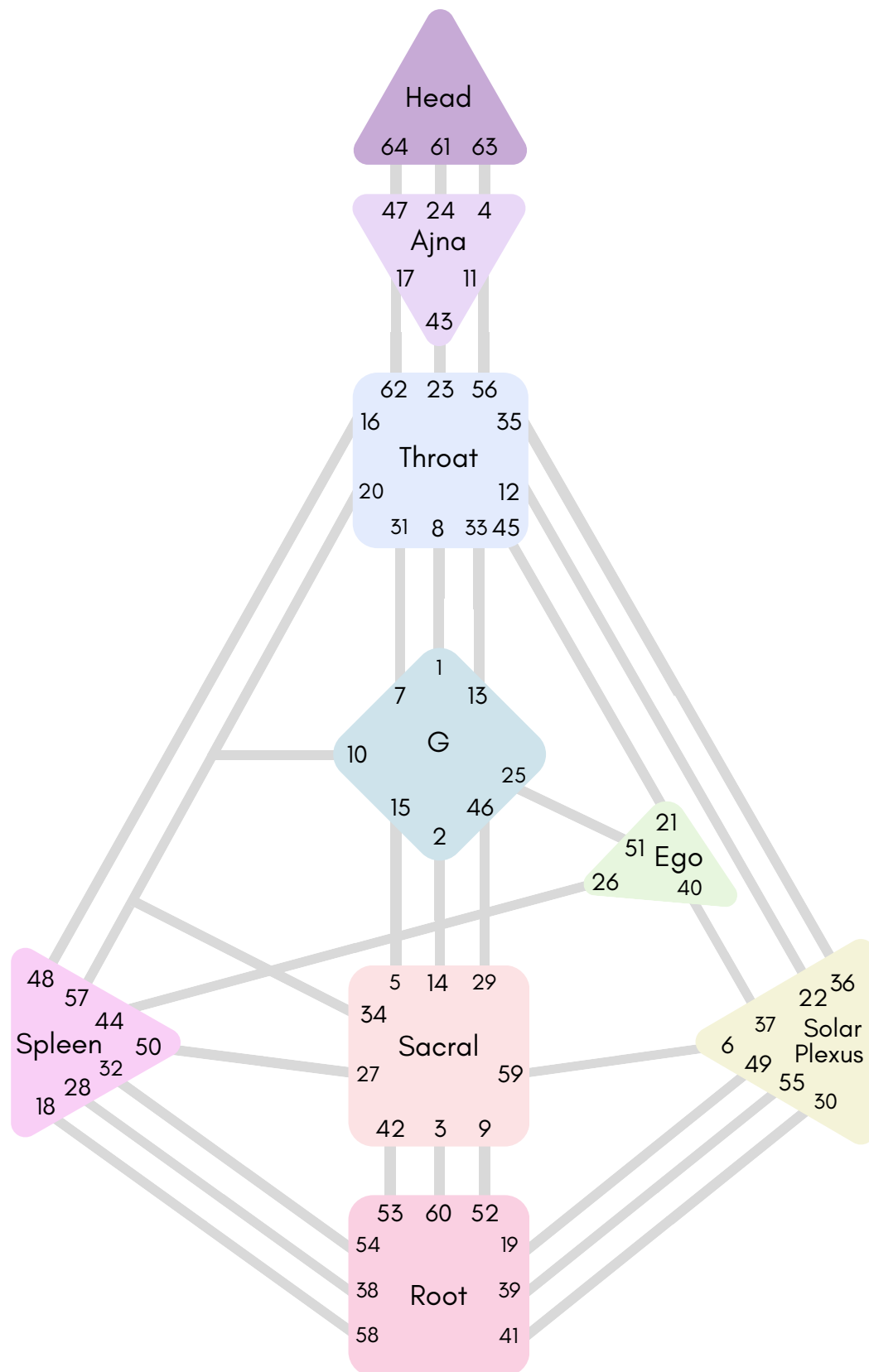

The Traditional Names of the 64 Gates

- | | | |
|----------------------|---------------------|------------------------------|
| 1. Self-Expression | 23. Assimilation | 45. The King or
The Queen |
| 2. Direction of Self | 24. Rationalization | 46. Determination |
| 3. Ordering | 25. Spirit of Self | 47. Realization |
| 4. Formulization | 26. The Egoist | 48. Depth |
| 5. Fixed Patterns | 27. Caring | 49. Principles |
| 6. Friction | 28. The Game Player | 50. Values |
| 7. Role of the Self | 29. Perseverance | 51. Shock |
| 8. Contribution | 30. Feelings | 52. Stillness |
| 9. Focus | 31. Influence | 53. Beginnings |
| 10. Behavior of Self | 32. Continuity | 54. Drive |
| 11. Ideas | 33. Privacy | 55. Spirit |
| 12. Caution | 34. Power | 56. Stimulation |
| 13. The Listener | 35. Change | 57. Intuitive Insight |
| 14. Power Skills | 36. Crisis | 58. Joy/Vitality |
| 15. Extremes | 37. Friendship | 59. Sexuality |
| 16. Skills | 38. The Fighter | 60. Acceptance |
| 17. Opinions | 39. Provocation | 61. Mystery |
| 18. Correction | 40. Aloneness | 62. Details |
| 19. Wanting | 41. Contraction | 63. Doubt |
| 20. The Now | 42. Growth | 64. Confusion |
| 21. Hunter/Huntress | 43. Insight | |
| 22. Openness | 44. Alertness | |

CURRENT TRANSITS CALENDAR

*For an updated-monthly transits
calendar for the Sun and New
Moon/Full Moon,*

**click below to download the
most current transits calendar!**



[CLICK HERE](#)

GATE 1

The Gate of Self-Expression	Scorpio	Creativity, Authenticity, Transformation
-----------------------------	---------	--

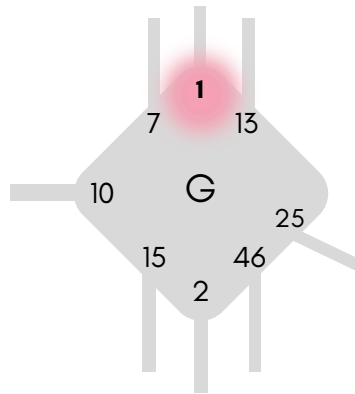

Higher Expressions of Gate 1:

- Honoring the natural ebbs and flows you experience with your own ability to create/be creative

Lower Expressions of Gate 1:

- Feeling like there's something wrong with you when you can't be creative all of the time
- Being extremely hard on yourself during times when you have low or flat energy
- Feeling an intense pressure to create something unique in the world

My Notes:

GATE 2

The Gate of Direction of
the Self

Taurus

Receptivity, Flow,
Abundance

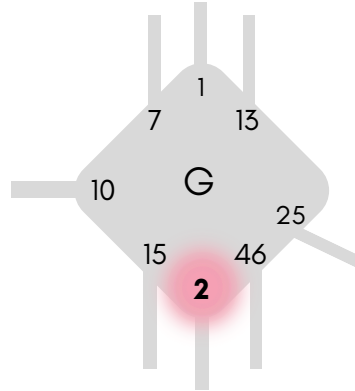

Higher Expressions of Gate 2:

- Intuitive alignment with the Universe's flow and your own flow
- Patiently allowing life to unfold naturally
- An open-hearted approach to life, welcoming opportunities and experiences that resonate with one's true self

Lower Expressions of Gate 2:

- Overwhelm and passivity
- Doubt and uncertainty about your purpose/direction
- Forced actions that can lead to misalignments

My Notes:

GATE 3

The Gate of Ordering	Aries / Taurus	New Beginnings, Creativity, Innovation
----------------------	----------------	---

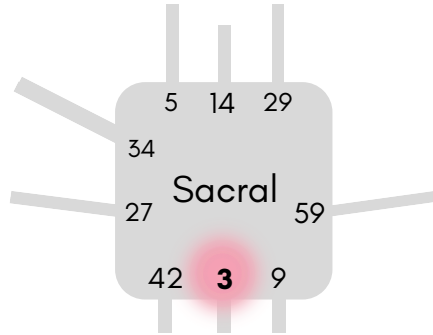

Higher Expressions of Gate 3:

- Innovative leadership
- Resilient adaptation in the face of challenges
- Powerful energy to withstand the stress of being limited
- Being an agent of transformation

Lower Expressions of Gate 3:

- Resistance to change
- Fear of failure
- Melancholic yearning for something new
- Using your resources to bring something new in your life that is not sustainable energetically

My Notes:

GATE 4

The Gate of Formulization	Leo	Discernment, Logic, Inquisitiveness
---------------------------	-----	--

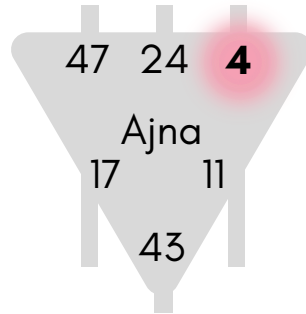

Higher Expressions of Gate 4:

- Intellectual curiosity and insight
- Effective problem-solving
- Ability to approach challenges with a clear, logical mindset
- A willingness to explore various perspectives and consider new ideas

Lower Expressions of Gate 4:

- Overthinking / mental strain
- Excessive doubt in yourself and in the intentions or capabilities of others
- Rigidity in thought
- Frustration of not finding immediate solutions to problems or questions

My Notes:

GATE 5

The Gate of Fixed Patterns	Sagittarius	Natural Rhythms, Trust, Patience
----------------------------	-------------	----------------------------------

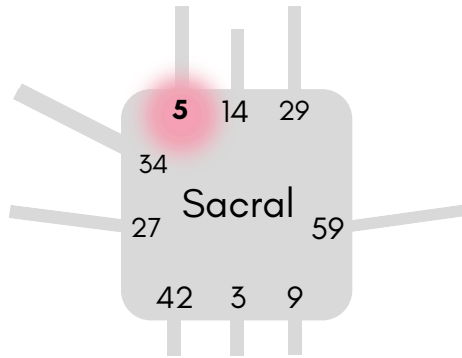

Higher Expressions of Gate 5:

- Deep alignment with the natural order and timing of events
- Finding comfort in routines while also remaining flexible
- Embracing any waiting periods as opportunities for growth and preparation, trusting that the right moments will present themselves with clear indicators for action
- Staying true to your own natural rhythms
- Remaining in your own flow and rhythm

Lower Expressions of Gate 5:

- Impatience and restlessness, leading to premature actions that may not be in sync with natural timing, resulting in less optimal outcomes
- Anxiety over the future
- Overreliance on routines to the point of rigidity
- Trying to push against the natural flow of life, where nothing seems easy
- Having a difficult time "going with the flow"
- Becoming upset when routines get interrupted
- Struggling to maintain habits that help create a stable and sustainable life

My Notes:

GATE 6

The Gate of Friction	Virgo	Conflict Resolution, Emotional Friction, Emotional Maturity
----------------------	-------	---

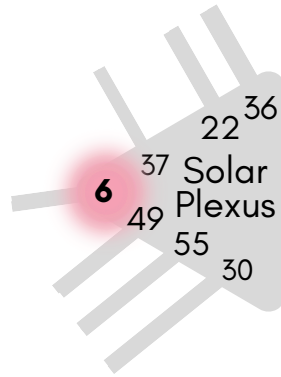

Higher Expressions of Gate 6:

- Emotional wisdom and meaningful relationships
- Deep understanding of your own emotional states and those of the people around them
- Conflict embraced as a path to growth and deeper understanding
- Compassionate mediation of conflicts

Lower Expressions of Gate 6:

- Tendency to react impulsively to emotional triggers, leading to unnecessary conflicts and the escalation of existing ones
- Emotional volatility
- Fear of vulnerability

My Notes:

GATE 7

The Gate of the Role of the Self in Interaction	Leo	Leadership, Logic, Future-Oriented
---	-----	------------------------------------

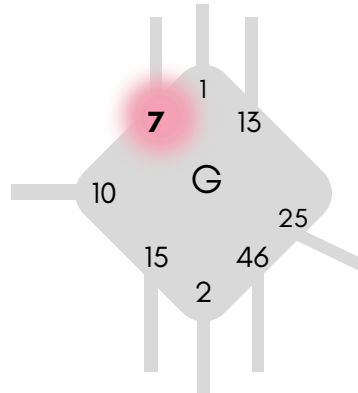

Higher Expressions of Gate 7:

- Inspiring those around you and leading by example
- Creating unity and collective effort rather than dominance or control
- A democratic approach to decision-making, where all voices are heard and valued
- Empowering others to find their unique strengths and roles within the group
- Flexible and adaptive leadership

Lower Expressions of Gate 7:

- Dominating / controlling others
- Ego-driven actions that cause losing sight of the collective vision and the well-being of the group
- Inflexibility in leadership
- Neglecting the needs of others

My Notes:

GATE 8

The Gate of Contribution	Taurus / Gemini	Authentic Expression, Unique Direction, Rebelliousness
--------------------------	-----------------	--

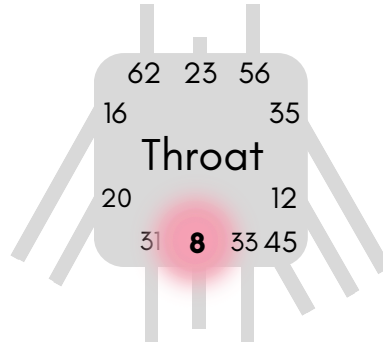

Higher Expressions of Gate 8:

- An internal drive to express one's uniqueness, regardless of how it is perceived by others
- A focus on the joy of creation, without seeking external validation
- Strong self-awareness and confidence in one's creative gifts
- Being a powerful force for inspiring change and innovation
- Communicating ideas and visions from a place of authenticity

Lower Expressions of Gate 8:

- Conformity
- Being overly focused on seeking external validation
- Suppression of one's unique ideas and true self

My Notes:

GATE 9

The Gate of Focus	Sagittarius	Details, Determination, Refinement
-------------------	-------------	------------------------------------

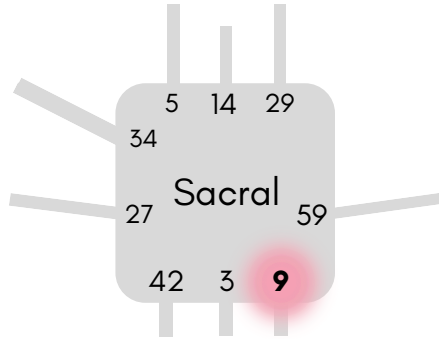

Higher Expressions of Gate 9:

- Utilizing detail-oriented skills to enhance efficiency and effectiveness in projects
- Balancing the focus on details with the ability to prioritize, distinguishing between what is more important/less important

Lower Expressions of Gate 9:

- Getting bogged down in the details to the point of paralysis
- Tendency to fixate on trivialities that may not significantly impact the overall outcome, leading to inefficiency or missed opportunities
- Frustration or impatience with others who may not share your level of detail orientation, potentially leading to misunderstandings or conflicts

My Notes:

GATE 10

The Gate of the Behavior of Self	Sagittarius / Capricorn	Self-love, Identity, Independence
----------------------------------	-------------------------	-----------------------------------

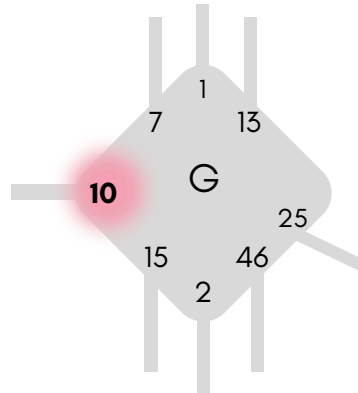

Higher Expressions of Gate 10:

- Practicing consistent self-love and nurturing a positive internal dialogue that reinforces your worth and potential
- Transforming past challenges into sources of strength and empowerment, viewing each obstacle as an opportunity to evolve
- Standing firm in your authenticity, living without apology for who you are, and thereby empowering others to do the same

Lower Expressions of Gate 10:

- Dwelling on past hurts or failures, adopting a victim mentality that hinders personal growth and self-worth
- Harboring negative self-talk and questioning one's value, leading to a cycle of self-doubt and diminished self-love
- Settling for less than what you deserve, whether in relationships, career, or personal goals, due to a lack of self-esteem or fear of asserting your true needs and desires

My Notes:

GATE 11

The Gate of Ideas	Sagittarius	Vessel for Ideas, Concepts, Right Timing
-------------------	-------------	---

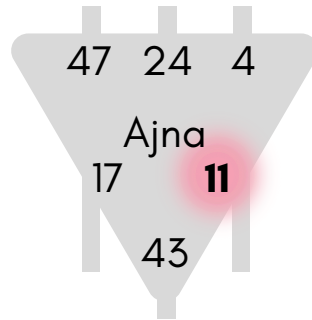

Higher Expressions of Gate 11:

- Innovative thinking / creating novel ideas
- Peacemaking abilities
- Channeling imagination toward creating ideas that enhance social harmony and progress
- Balancing idealism with realism, ensuring that visionary ideas can be effectively implemented and embraced by the community

Lower Expressions of Gate 11:

- Being overly idealistic, to the point where ideas are impractical or disconnected from real-world applications
- Holding back innovative thoughts for fear they won't be accepted or understood by others
- Being overwhelmed by possibilities and ideas, finding it difficult to focus on one thing, jumping from one thought to another without practical application
- An overemphasis on how things could be rather than dealing with how things are, resulting in frustration and inaction

My Notes:

GATE 12

The Gate of Caution	Gemini	Discrimination, Emotional Communication, Creative Power
---------------------	--------	---

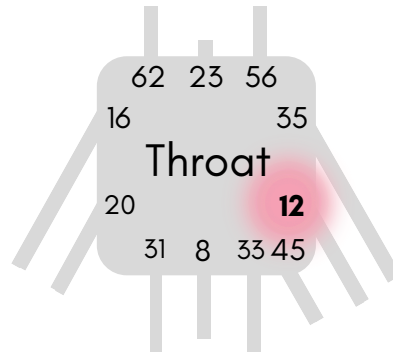

Higher Expressions of Gate 12:

- Deep reflection and consideration before taking action or expressing thoughts
- Utilizing caution as a strength, allowing for thorough assessment and informed decision-making that considers potential outcomes and consequences
- Balancing the tendency towards hesitation with the ability to dream big
- Choosing to speak with intention and purpose

Lower Expressions of Gate 12:

- Excessive caution that leads to missed opportunities or an inability to take necessary risks for growth and progress
- Procrastination or inaction due to an overwhelming sense of hesitancy and fear of potential pitfalls, stifling personal and professional development

My Notes:

GATE 13

The Gate of the Listener	Aquarius	Empathy, Storytelling, Listening, Learning
--------------------------	----------	---

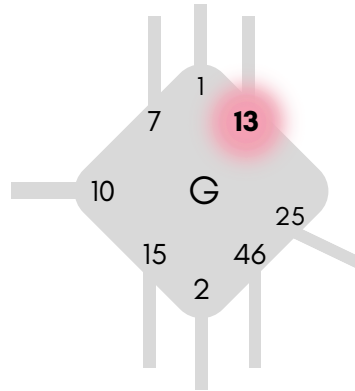

Higher Expressions of Gate 13:

- Empathetic listening
- Confidentiality and trust
- Finding wisdom in stories to help guide and enlighten others
- Emotional intelligence

Lower Expressions of Gate 13:

- Being overwhelmed with your emotions and the emotions of other people
- Gossiping and misusing stories
- Loss of your own personal narrative (losing touch with your own story)
- Difficulty detaching from the emotional weight of other peoples' stories

My Notes:

GATE 14

The Gate of Power Skills	Scorpio / Sagittarius	Resource Management, Prosperity, Abundance, Expansion
--------------------------	-----------------------	---

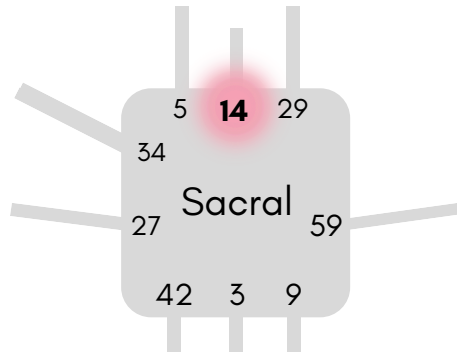

Higher Expressions of Gate 14:

- Ability to attract and manage wealth effectively
- Feeling empowered and in control of your destiny and resources
- Generosity toward others
- Confident and competent management of resources, viewing wealth as not just a personal asset but a tool for broader positive impact

Lower Expressions of Gate 14:

- Mismanagement of resources or opportunities due to a lack of alignment with true passions or a disregard for the broader impact of one's actions
- Overwhelm or anxiety in the face of financial responsibilities
- Excessive focus on accumulating wealth and possessions, leading to a life that values material success over emotional or spiritual fulfillment
- A need to dominate or control others, potentially leading to conflicts and strained relationships.
- Fear of scarcity

My Notes:

GATE 15

The Gate of Extremes	Gemini	Extremes, Rhythms, Flow, Compassion, Magnetism
----------------------	--------	--

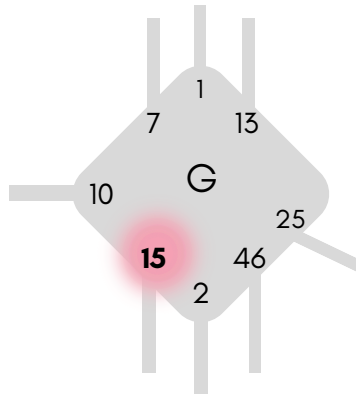

Higher Expressions of Gate 15:

- Maintaining your own rhythms and flow
- Bringing people together, fostering a sense of community and shared purpose
- Having healthy boundaries, ensuring that you can provide support for others without compromising your own well-being
- Embodying the essence of universal love and humanitarianism

Lower Expressions of Gate 15:

- Difficulty in setting boundaries, which may result in feeling overburdened by the responsibility of being a support system for many
- Discomfort or resistance in situations where personal freedom feels compromised, potentially leading to conflicts or a sense of entrapment
- Difficulty in managing the highs and lows of life, leading to feelings of overwhelm or inconsistency in your energy and engagement with life
- A resistance to or difficulty in maintaining regular routines, which can affect personal productivity and stability

My Notes:

GATE 16

The Gate of Skills	Gemini	Enthusiasm, Skills, Mastery
--------------------	--------	-----------------------------

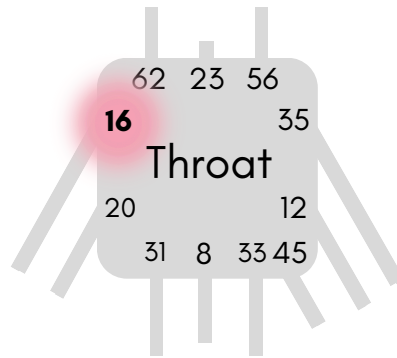

Higher Expressions of Gate 16:

- Genuine enthusiastic expression
- Ability to adapt to new situations and embrace various interests with open arms, while still committing to mastery.
- Dedication to mastering the skills that truly resonate with your core

Lower Expressions of Gate 16:

- A scattering of energies across too many interests, resulting in a lack of depth in any particular area, feelings of unfulfillment, or the sense that one's talents are not being fully realized
- Overenthusiasm leading to overcommitment/burnout
- Fear of Missing Out (FOMO), preventing a deep commitment to any single path or skill, hindering the process of mastery and personal development
- Difficulty in focusing

My Notes:

GATE 17

The Gate of Opinions	Aries	Strong Opinions, Innovative Thinking
----------------------	-------	---

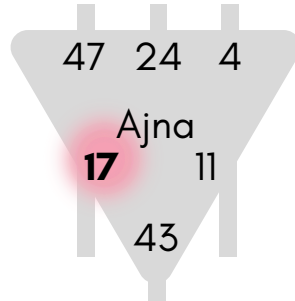

Higher Expressions of Gate 17:

- Flexibility in thinking
- Self-assurance and confidence in one's opinions (without the need for constant external validation)
- Balanced communication/Harmonious balance between speaking and listening
- Constructive debating/Valuing the process of sharing and refining ideas together

Lower Expressions of Gate 17:

- Rigidity in opinions
- Basing one's self-worth on external validation of opinions
- Dominating conversations, where the desire to express opinions overshadows the ability to listen
- Conflict orientation, i.e. having a propensity for arguments and conflicts, particularly when your opinions are challenged or not accepted by others

My Notes:

GATE 18

The Gate of Correction	Libra	Correction, Improvement, Refinement
------------------------	-------	-------------------------------------

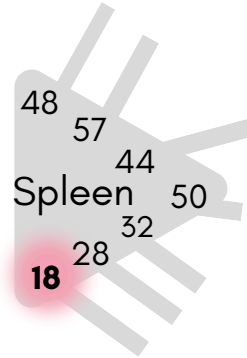

Higher Expressions of Gate 18:

- Offering insights and suggestions to others in a manner that is empowering and supportive, focusing on solutions rather than problems
- Applying the energy of correction towards personal growth and self-awareness, recognizing one's own areas for development without self-judgment
- Utilizing discernment to identify areas where societal or community improvement is needed and contributing positively towards these changes

Lower Expressions of Gate 18:

- A tendency to focus predominantly on flaws or imperfections, often overlooking the good or the progress already made
- Offering corrections or improvements without invitation, which may not be well-received or appropriate in all situations
- Perfectionism

My Notes:

GATE 19

The Gate of Wanting	Aquarius	Sensitivity, Intuition, Empathy
---------------------	----------	------------------------------------

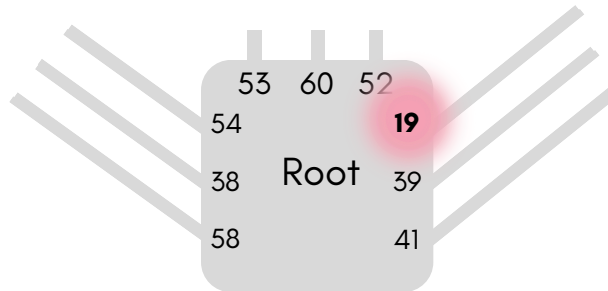

Higher Expressions of Gate 19:

- The purest form of empathy and understanding
- Primal need for community, belonging, and emotional connections
- Easily understanding and relating to the emotions of those around you
- Creating and nurturing bonds between people in your community
- Allowing your intuition to guide your interactions so you can respond effectively to the emotional and physical needs of the people and animals around you

Lower Expressions of Gate 19:

- Emotional over-sensitivity
- A tendency to take on the emotions of others
- Feelings of vulnerability or feelings of being overwhelmed, especially in heavily populated social settings
- Mood swings
- Emotional instability
- An excessive need for emotional validation and support from others

My Notes:

GATE 20

The Gate of the Now	Gemini	Present Moment, Patience, Authenticity
---------------------	--------	---

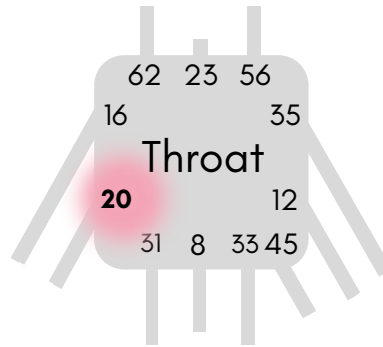

Higher Expressions of Gate 20:

- Cultivating a deep sense of presence in the moment
- Embracing the practice of mindfulness, allowing for a heightened awareness and appreciation of life's simple pleasures
- Inspiring those around you to engage more fully with the present moment, thereby fostering a collective sense of peace and groundedness

Lower Expressions of Gate 20:

- Struggling with past memories or future worries, which can cloud the clarity and peace found in present-moment awareness
- Difficulty in finding stillness or feeling disconnected from the immediate reality, leading to restlessness or disengagement

My Notes:

GATE 21

The Gate of the Hunter/ Huntress	Aries	Control, Leadership, Resource Management
-------------------------------------	-------	---

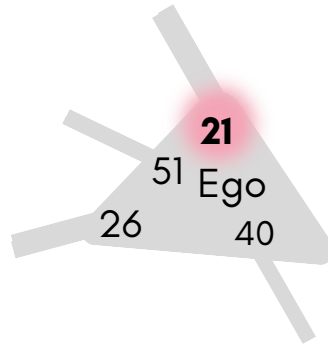

Higher Expressions of Gate 21:

- Effective leadership marked by a balanced approach to control, focusing on the greater good
- Managing resources (time, money, energy) effectively and fairly, ensuring that everyone benefits from decisions that are made
- Empowerment of people by encouraging independence and self-reliance, fostering a sense of shared responsibility and teamwork
- Openness to change and new ideas

Lower Expressions of Gate 21:

- Overbearing control, micromanagement, and an inability to trust others' abilities
- Rigidity, insisting on only one way of doing things and being resistant to change
- Possessiveness over resources, people, or situations, often stemming from a fear of losing control
- Conflict/power struggles, in personal relationships and professional environments

My Notes:

GATE 22

The Gate of Openness	Pisces	Artistic Genius, Social Grace, Resilience
----------------------	--------	---

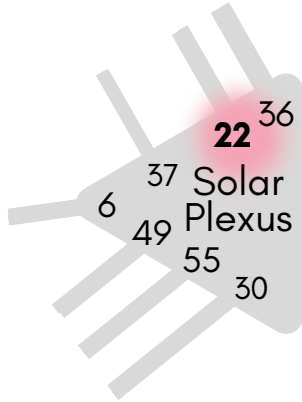

Higher Expressions of Gate 22:

- Empathetic understanding of others' emotions without being overwhelmed by them
- The gift of artistic expression, where you channel your emotional depth into creative pursuits
- Ability to navigate social situations with grace and charm
- Emotional resilience, the ability to handle emotional fluctuations in yourself and others with ease

Lower Expressions of Gate 22:

- Emotional overwhelm
- Being excessively influenced by others' emotions
- Social anxiety/acute sensitivity to social atmospheres
- Artistic/creative blockage
- Difficulty in communicating emotions effectively

My Notes:

GATE 23

The Gate of Assimilation	Taurus	Communication, Clarity, Innovation
--------------------------	--------	---------------------------------------

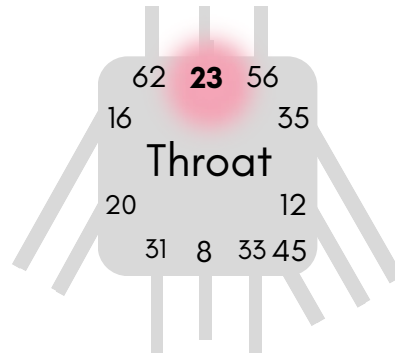

Higher Expressions of Gate 23:

- An ability to convey complex ideas in a way that is easy for others to understand.
- Innovative thinking, bringing forward new ideas that can lead to significant changes or improvements in society
- Using communication as a tool to inspire positive change in others
- Knowing when the time is right to share ideas for maximum impact

Lower Expressions of Gate 23:

- Feeling misunderstood or ahead of your time, leading to withdrawal from sharing ideas
- Trying to force ideas onto others before they are ready to receive them
- Diluting your ideas too much in an attempt to be understood, losing the essence of the message
- Becoming overly critical of yourself or others when there is a lack of understanding or acceptance of your ideas

My Notes:

GATE 24

The Gate of Rationalization	Taurus	Silence, Deep Thinking, Insight
-----------------------------	--------	---------------------------------

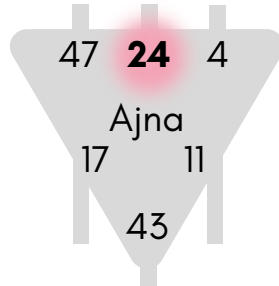

Higher Expressions of Gate 24:

- Refinement of existing ideas
- Clear, insightful thinking
- The ability to process complex ideas and reach profound conclusions
- Innovative problem-solving
- Ability to navigate through mental challenges without being overwhelmed by the cyclical nature of thoughts

Lower Expressions of Gate 24:

- Being stuck in repetitive cycles of thinking, unable to move forward or find resolution
- Over-rationalization of emotions and experiences, leading to a disconnect from your intuition or feelings
- Resistance to change, where you prefer the comfort of familiar but unproductive thought patterns

My Notes:

GATE 25

The Gate of the Spirit of the Self	Pisces	Universal Love, Altruism, Spiritual Depth
------------------------------------	--------	---

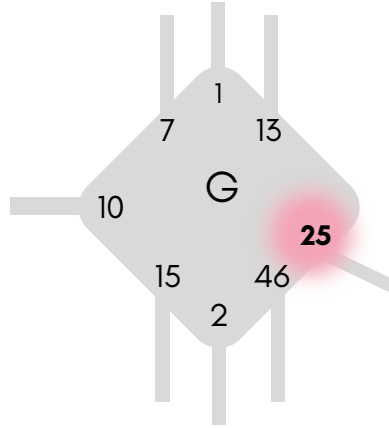

Higher Expressions of Gate 25:

- Universal, unconditional love
- Selfless service
- A healing, calming presence
- An innocent and pure approach to life
- Spiritual connection/feeling of oneness with the Universe

Lower Expressions of Gate 25:

- A tendency to over-sacrifice one's own needs for others, which may lead to burnout and resentment
- A sense of disconnection or isolation from others
- Loss of self-identity
- Naivety or a lack of discernment in relationships and situations
- Martyrdom, where individuals constantly sacrifice themselves, sometimes unnecessarily, for the sake of others

My Notes:

GATE 26

The Gate of the Egoist	Sagittarius	Truth, Integrity, Salesmanship, Pride
------------------------	-------------	--

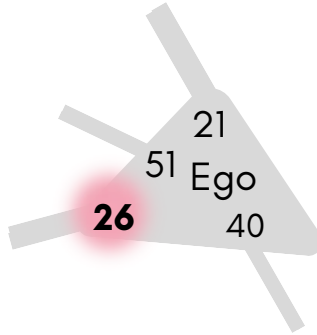

Higher Expressions of Gate 26:

- Ethical persuasion, guiding others towards positive choices and beneficial outcomes
- Defending/promoting the welfare of others
- Resilient motivation to persevere through difficulties and pursue goals with vigor

Lower Expressions of Gate 26:

- Using persuasion for selfish or unethical purposes
- Being manipulative, using cunning to bend others to your will without regard for their well-being or ethical considerations
- Overwhelming dominance, bulldozing over others' opinions and desires, focusing only on selfish needs and wants
- Ruthless ambition, compromising values to achieve material or social success

My Notes:

GATE 27

The Gate of Caring	Taurus	Nurturing, Responsibility, Care-Taking
--------------------	--------	---

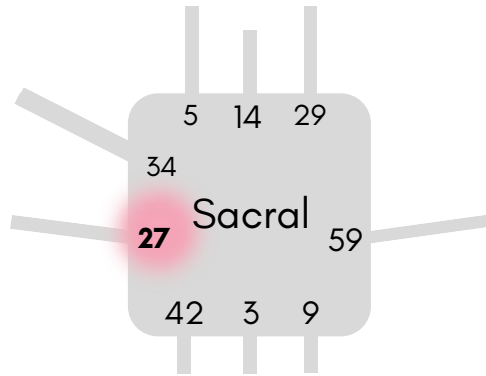

Higher Expressions of Gate 27:

- Exhibiting a deep, empathetic understanding of others' needs, providing care that empowers and supports without overwhelming
- Healthy self-care/making sure your own needs are met
- Contributing to the well-being of the community or family in a balanced manner, recognizing the collective's needs without neglecting personal boundaries
- Nurturing others in a way that encourages and empowers others to be self-sufficient and strong

Lower Expressions of Gate 27:

- Overbearing care, including smothering or controlling behavior under the guise of care, which can stifle the growth and independence of others
- Neglect of self through over-focus on others' needs
- Martyrdom - sacrificing oneself excessively and unnecessarily for others.
- Manipulative nurturing, using nurturing and care as a means to control or manipulate others
- Encouraging dependency rather than supporting others to be self-reliant and empowered

My Notes:

GATE 28

The Gate of the Game Player	Scorpio	Adventure, Challenge, Risk
--------------------------------	---------	-------------------------------

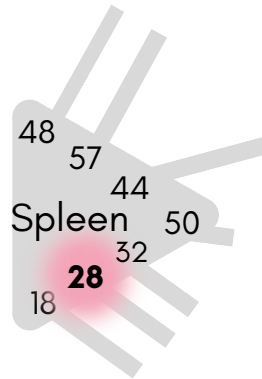

Higher Expressions of Gate 28:

- Finding the silver lining in difficult situations, transforming obstacles into stepping stones towards personal growth and fulfillment
- Purposeful risk-taking, where risks are taken with a clear intention and understanding of their potential to lead to greater self-awareness and fulfillment in life
- The understanding that struggles are not merely hardships but essential elements of life, offering unique lessons and opportunities for personal development
- Finding joy not just in achieving goals but in the process of pursuing them

Lower Expressions of Gate 28:

- Being overwhelmed by the fear of a meaningless life
- Reckless risk-taking, without consideration of their purpose or potential consequences
- Despair in the face of challenges
- A belief that nothing matters

My Notes:

GATE 29

The Gate of Perseverance	Leo / Virgo	Commitment, Determination, Devotion
--------------------------	-------------	--

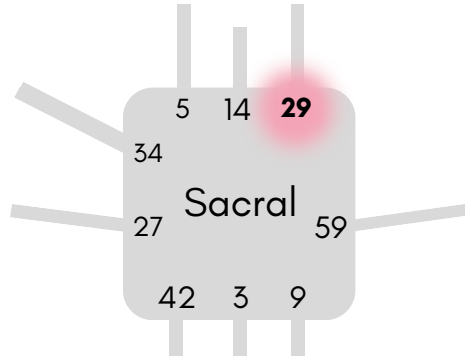

Higher Expressions of Gate 29:

- The ability to make wise choices about what you commit to, where what you say yes to aligns with your true desires and life path
- Sustainable enthusiasm, action, and energy throughout your commitments
- Maintaining the perfect balance between saying "yes" and knowing when to say "no"

Lower Expressions of Gate 29:

- Overcommitment, the tendency to say "yes" too often to activities or relationships that do not serve your higher purpose
- Difficulty in saying no, leading to resentment and depletion of energy.
- Persistence in commitments that are no longer beneficial

My Notes:

GATE 30

The Gate of Feelings	Aquarius / Pisces	Passion, Desire, Emotion
----------------------	-------------------	--------------------------

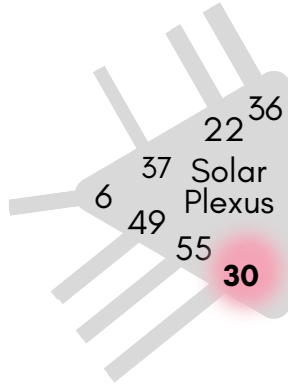

Higher Expressions of Gate 30:

- Having a mature understanding of desires
- Recognizing the transient nature of emotions and the importance of not being impulsively driven by them
- Channeling intense emotions into creative or productive endeavors
- Emotional resilience/the ability to navigate life's ups and downs with a balanced perspective
- Fostering environments where feelings are acknowledged and respected

Lower Expressions of Gate 30:

- Emotional turbulence/being caught in a whirlwind of intense desires
- Impulsivity and being obsessed with unattainable desires
- Emotional instability in relationships
- Difficulty in fulfill your desires

My Notes:

GATE 31

The Gate of Influence	Leo	Influence, Future, Collective Leadership
-----------------------	-----	---

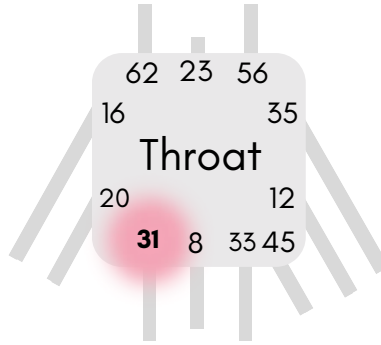

Higher Expressions of Gate:

- Democratic leadership characterized by empathy and unity
- Communication that inspires action and change
- Service-oriented leadership/commitment to serving the collective good

Lower Expressions of Gate:

- Manipulative communication tactics
- Authoritative leadership, with individuals insisting on their way as the only way, stifling dissent and collaboration
- Leadership driven by ego rather than by the desire to serve

My Notes:

GATE 32

The Gate of Continuity	Libra	Instincts, Intuition, Endurance
------------------------	-------	------------------------------------

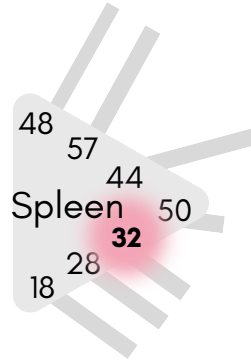

Higher Expressions of Gate:

- Being adept at navigating change, using deep-seated fears of failure as catalysts for innovation rather than obstacles
- Deep trust in your intuition
- Embracing change as an essential part of life
- Discernment in where and with whom you invest your time and resources

Lower Expressions of Gate:

- Fear of the unknown, which can become paralyzing
- Resistance to change, leading to stagnation
- Tendency to have poor judgment in investments—whether emotional, financial, or intellectual—that are not aligned with your true path

My Notes:

GATE 33

The Gate of Privacy	Leo	Contemplation, Solitude, Wisdom
---------------------	-----	------------------------------------

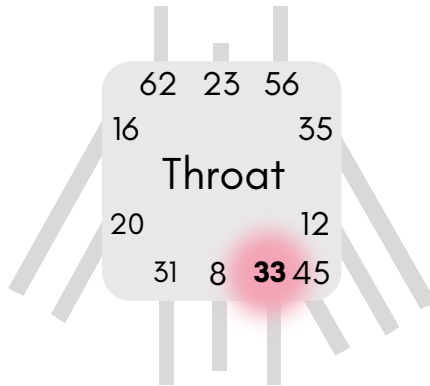

Higher Expressions of Gate:

- Gaining wisdom through solitude and reflection
- Sharing wisdom with others in a way that is impactful and transformative
- Embracing solitude/withdrawal as a deliberate choice for personal growth and clarity

Lower Expressions of Gate:

- Isolation that stems not from a healthy need for reflection but from a fear of vulnerability or rejection
- Loneliness and a disconnection from others
- Miscommunication or withholding valuable insights due to timing misjudgments or a lack of confidence in your voice

My Notes:

GATE 34

The Gate of Power	Sagittarius	Power, Action, Self-Reliance
-------------------	-------------	------------------------------

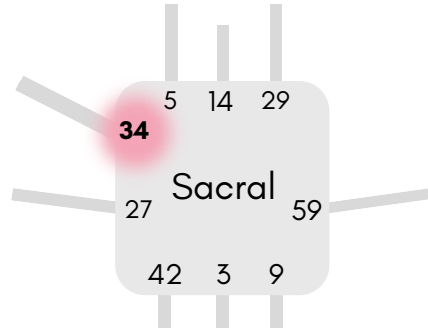

Higher Expressions of Gate:

- Attuning yourself to using your own personal power in a way that is aligned with your Strategy and Authority
- Actions driven by alignment with your inner truth and purpose
- Recognition of your power and your strengths, trusting your instincts, and the ability to act independently toward your personal goals
- The power inherent in this Gate is used not only for personal advancement but also to empower and uplift others

Lower Expressions of Gate:

- Actions taken without alignment to your inner truth or Higher self, which can lead to exhaustion or fruitlessness
- Overreliance on yourself, leading to isolation or a refusal to collaborate with others
- Misusing your power/power being used manipulatively or aggressively

My Notes:

GATE 35

The Gate of Change	Gemini	The Quest for Meaning, Adventure, Self-Discovery
--------------------	--------	--

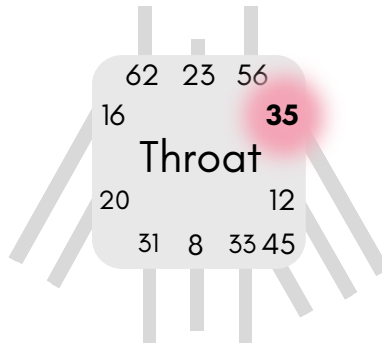

Higher Expressions of Gate:

- Embracing change, not just for the sake of novelty but for the profound growth and understanding that can come from it
- Extracting wisdom through experience
- Navigating life's inevitable changes with grace and resilience
- Constructive communication, where experiences and insights are articulated so as to enlighten others

Lower Expressions of Gate:

- Restlessness and dissatisfaction with the status quo, leading to a constant but unfulfilled quest for new experiences
- Incessant need for change that stems from a place of dissatisfaction
- Lack of depth—skimming the surface of experiences without engaging deeply enough to extract their true value
- Challenges in communicating your experiences and insights effectively, potentially leading to misunderstandings or a sense of isolation

My Notes:

GATE 36

The Gate of Crisis	Pisces	Sensitivity, Emotional Intensity, Creative Problem-Solving
--------------------	--------	--

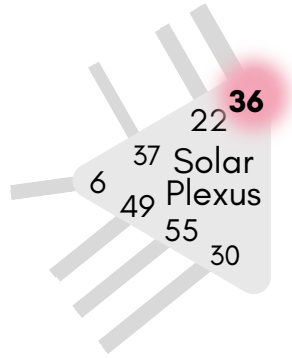

Higher Expressions of Gate:

- Deep understanding of emotions and ability to navigate them with grace and wisdom
- Ability to face life's challenges without being overwhelmed
- Viewing crises as catalysts for growth
- Heightened sense of empathy
- Ability to think creatively and find innovative solutions in the face of adversity

Lower Expressions of Gate:

- Emotional instability and overwhelm
- A tendency to create or get drawn into unnecessary crises, often as a subconscious way of seeking emotional stimulation
- Acting on the spur of the moment without considering the consequences, driven by intense emotional states
- Difficulty in learning from experiences, leading to repeated patterns of emotional distress.

My Notes:

GATE 37

The Gate of Friendship	Pisces	Emotional Intelligence, Family & Community
------------------------	--------	---

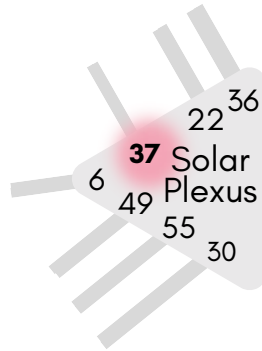

Higher Expressions of Gate:

- Being a peacekeeper
- Fostering emotional support and understanding, creating an environment where everyone feels valued and heard
- Strong emotional intelligence
- Being adept at managing your emotions and navigating complex emotional landscapes within your relationships, promoting mutual understanding and respect.
- Harmonious exchanges with others

Lower Expressions of Gate:

- Emotional imbalances/moodiness/an inability to manage your emotional responses effectively
- Emotional manipulation
- Disconnection from your family or community
- Difficulties in communication, especially in emotional contexts
- Struggle with give-and-take, resulting in one-sided relationships, where the balance of support, emotional or otherwise, is skewed

My Notes:

GATE 38

The Gate of the Fighter	Cancer	Opposition, Resilience, Struggle
-------------------------	--------	----------------------------------

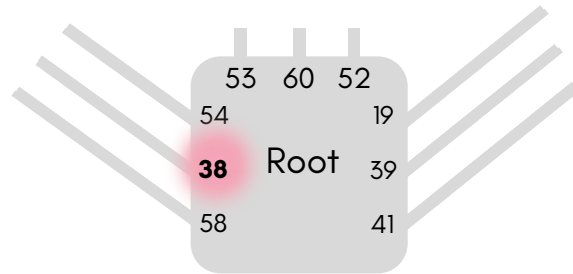

Higher Expressions of Gate:

- Fighting for meaningful causes and standing up for what you believe in, driven by a moral or ethical imperative
- Resilience and endurance in the face of challenges
- Using opposition as a way to empower yourself and others

Lower Expressions of Gate:

- Senseless rebellion or opposition without a cause
- Conflicts that are driven by a desire to fight rather than a need to address genuine issues, resulting in wasted energy and potential burnout
- Pessimism and isolation due to continual struggles
- Stubbornness and unwillingness to compromise, even when flexibility could lead to better outcomes

My Notes:

GATE 39

The Gate of Provocation	Cancer	Provocation, Excess, Dynamism
-------------------------	--------	----------------------------------

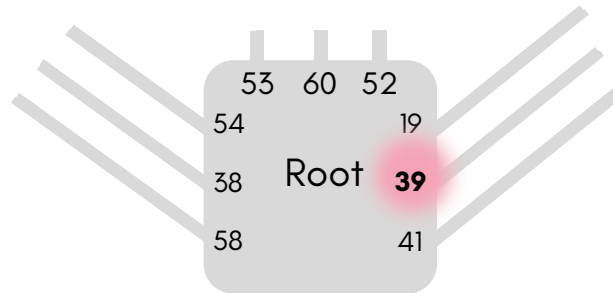

Higher Expressions of Gate:

- Provoking change in an empathetic manner through a deep understanding of your emotional landscape and the emotional landscape of others
- Ability to see beyond the surface, so as to inspire others to confront and transcend their limitations
- Challenging the status quo to opens up new possibilities and pathways that may have been previously unconsidered
- Empowerment of others by encouraging them to embrace their authentic selves and pursue their true desires, leading to greater fulfillment and happiness

Lower Expressions of Gate:

- Little awareness and control over emotional energy, leading to unintentional conflicts with others
- Emotional volatility
- Lack of empathy or understanding about the impact that your words and actions can have on others
- An eagerness to provoke change or awakenings in others without considering their readiness or feelings
- Excesses of various kinds

My Notes:

GATE 40

The Gate of Aloneness	Virgo	Independence, Self-Reliance, Boundaries
-----------------------	-------	---

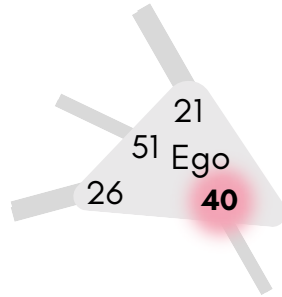

Higher Expressions of Gate:

- Self-reliance
- Strength in solitude
- Healthy independence
- Balancing your obligations to others with your need for personal space
- Ability to communicate your need for space and solitude in ways that are understood and respected by others

Lower Expressions of Gate:

- Isolation and loneliness
- An overwhelming sense of duty, where you feel enslaved by your commitments
- Difficulty in communicating needs for independence without offending or hurting others

My Notes:

GATE 41

The Gate of Contraction

Aquarius

Fantasy, Imagination,
Hopes & Dreams

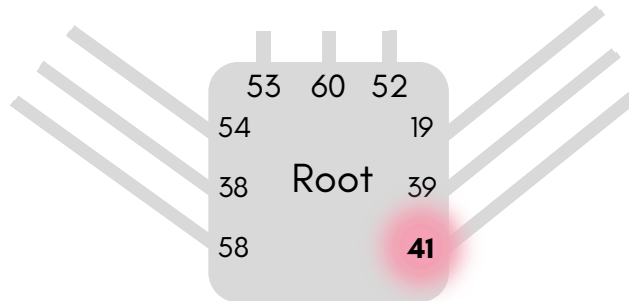

Higher Expressions of Gate:

- Endless innovation and hope
- Ability to manifest your dreams and aspirations
- Imagining what is possible, but where you are also able let go of expectations
- Gratitude for what you have already created in life
- Creativity, enthusiasm, and visionary thinking
- Daring to dream big, with the tenacity to make those dreams a reality

Lower Expressions of Gate:

- A sense of restlessness
- Unquenchable thirst for something new, often leading to dissatisfaction with the present
- Feelings of incompleteness or an incessant desire for change
- Being so caught up in "what could be" that you may miss the beauty and opportunities that are around you in the moment

My Notes:

GATE 42

The Gate of Growth	Aries	Endings, Transitions, Renewal
--------------------	-------	----------------------------------

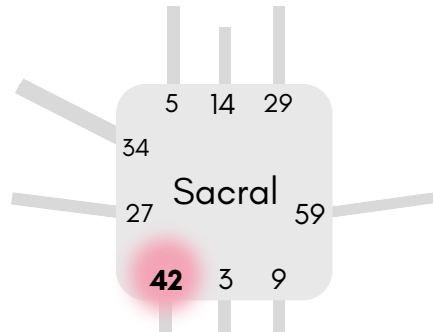

Higher Expressions of Gate:

- Clear understanding of when and how to end a cycle
- Embracing new beginnings and openness to new experiences
- Feeling of being excited about the possibilities that follow after the conclusion of something
- Heightened sense of intuition and wisdom guiding decisions about endings and transitions

Lower Expressions of Gate:

- A tendency to cling to situations, relationships, or projects past their natural expiration date, often driven by fear or emotional attachment
- Struggle with recognizing when it's time to let go, leading to prolonged periods of stagnation or feeling unfulfilled

My Notes:

GATE 43

The Gate of Insight	Scorpio	Intuitive Insights, Non-Conformist, Inner Ear
---------------------	---------	--

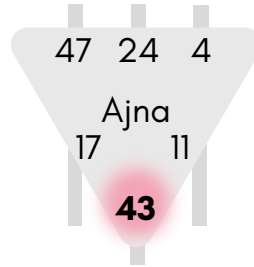

Higher Expressions of Gate:

- Mental acuity
- Ability to listen to and trust your unique inner voice
- Innovative thinking
- Effectively communicating your insights at the right time

Lower Expressions of Gate:

- Fear of rejection
- Impatience and frustration when others do not immediately understand or accept your visionary ideas
- Miscommunication if insights are delivered without regard for timing or audience readiness
- Inability to hear your unique voice

My Notes:

GATE 44

The Gate of Alertness	Scorpio	Intuitive Decision-Making, Survival Instincts, Memory
-----------------------	---------	--

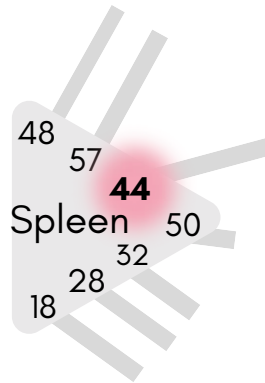

Higher Expressions of Gate:

- Ability to recognize patterns to make proactive and informed decisions.
- Strong connection to instinctual knowledge
- Ability to make quick and effective decisions, often guided by a gut feeling
- Protective insight for yourself and others due to awareness of potential pitfalls based on past experiences
- Ability to trust your instincts and not being afraid to act on them, even if they go against conventional wisdom

Lower Expressions of Gate:

- Paralyzing fear that past negative experiences will repeat themselves
- Anxiety over situations that resemble past negative experiences, even if the current circumstances are different
- Expecting the worst based on past outcomes

My Notes:

GATE 45

The Gate of the King/Queen	Gemini	Authority, Wealth, Distribution
----------------------------	--------	---------------------------------

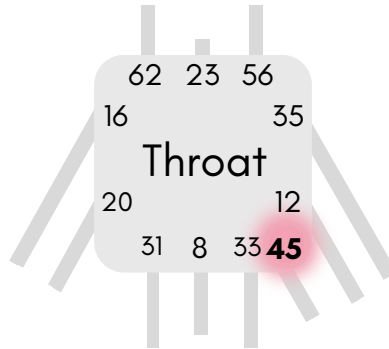

Higher Expressions of Gate:

- Enlightened leader who understands the profound responsibility of managing resources ethically, wisely, and for the collective good
- Deep sense of stewardship
- Being a caretaker of the collective's wealth, ensuring that resources are distributed in a way that supports the well-being and growth of all
- Generosity and open-heartedness
- Forward-thinking and innovative leadership, with the ability to inspire and mobilize communities toward a common goal

Lower Expressions of Gate:

- A tendency to control resources and hoard wealth and opportunities out of fear or greed
- Self-serving leadership, focused more on personal power and recognition than on the welfare of the community
- Rigid, authoritarian decision-making processes, where input from others is disregarded

My Notes:

GATE 46

The Gate of Determination	Virgo	Love of the Body, Synchronicity, Serendipity
---------------------------	-------	--

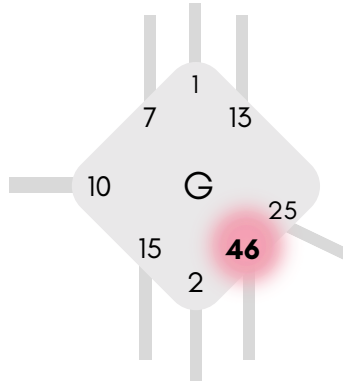

Higher Expressions of Gate:

- A deep, intrinsic joy derived from simply being alive and experiencing life through your body
- Recognition and appreciation of the body's abilities, leading to care and respect for it
- Ability to attract beneficial circumstances and people simply by being in the present moment
- Being in the right place at the right time

Lower Expressions of Gate:

- Feeling disconnected from your body
- Neglecting your physical health
- A sense of being out of place or in the wrong place
- Ignoring your physical needs
- Difficulty feeling anchored in the present moment

My Notes:

GATE 47

The Gate of Realization	Virgo	A-Ha Moments, Mental Exploration, Divine Timing
-------------------------	-------	---

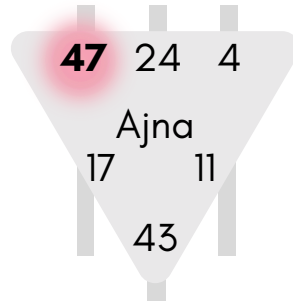

Higher Expressions of Gate:

- Ability to derive deep, meaningful insights from complex situations
- Understanding that insights will come at the right time, and there is no need to force clarity
- Ability to think about problems or puzzles in ways that are productive rather than debilitating
- Sharing insights with others, helping them to find their path to clarity and understanding

Lower Expressions of Gate:

- Feeling bombarded by thoughts, leading to confusion
- Getting lost in your own thoughts without a clear direction
- Frustration due to a perceived lack of answers or clarity
- A tendency to ruminate on problems without reaching any resolution
- Feeling misunderstood due to being unable to articulate your inner thoughts

My Notes:

GATE 48

The Gate of Depth	Libra	Resourceful Creativity, Wisdom, Embodiment
-------------------	-------	---

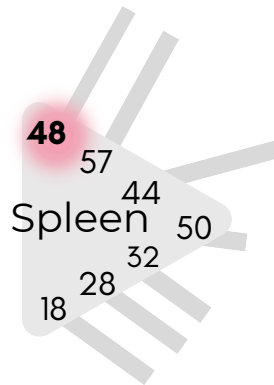

Higher Expressions of Gate:

- Drive to deepen your understanding and proficiency in specific areas of interest
- Relentless pursuit of knowledge
- Ability to apply knowledge practically and effectively in various situations, offering invaluable insights when needed
- Confidence in your intuitive insights, where you allow yourself to be guided by an instinctual understanding that what you feel intuitively
- Generosity in sharing knowledge, without fear of being seen as inadequate

Lower Expressions of Gate:

- Fear of inadequacy/deep-seated fear of not knowing enough or not being good enough
- Perfectionism, where the quest for complete and thorough understanding becomes a hindrance
- Procrastination due to the fear of making a mistake or not being fully prepared
- Overwhelm and anxiety due to the vast amount of information you perceive you need to learn
- Hoarding knowledge, where you become so focused on accumulating information that you lose sight of its practical application or the benefits of sharing it with others

My Notes:

GATE 49

The Gate of Principles	Aquarius	Revolution, Transformation, Principles
------------------------	----------	--

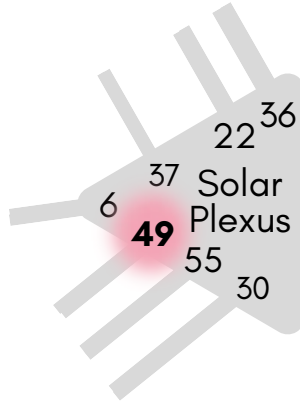

Higher Expressions of Gate:

- Profound drive toward meaningful, ethical change
- Deep empathy for others
- Driven by a strong moral compass to initiate change
- Ability to harness the emotions of yourself and others for constructive transformation
- Ability to navigate your own emotional landscape and recognize when it's time to let go of the old to make way for the new

Lower Expressions of Gate:

- Emotional turbulence and stubborn resistance to change
- Being reactionary instead of revolutionary, driven more by personal angst than by a desire for the greater good
- Being trapped in cycles of emotional highs and lows, making decisions based on momentary feelings rather than from following a consistent moral compass
- Fear of change

My Notes:

GATE 50

The Gate of Values	Libra/Scorpio	Ethical Responsibility, Morality, Duty
--------------------	---------------	---

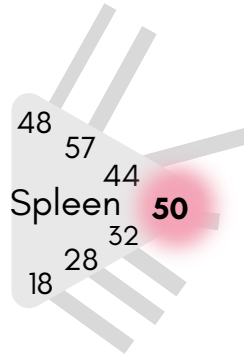

Higher Expressions of Gate:

- Driven by a profound sense of duty to protect and nurture others
- Deep empathy towards others, intuitively sensing what others need for emotional and physical security
- Strong adherence to ethical codes and moral integrity
- Advocating for fairness and justice, inspiring others to live up to ethical standards
- Actively preserving cultural heritage and traditions that promote unity and collective identity

Lower Expressions of Gate:

- Feeling excessively burdened by responsibilities
- Fear of punishment or negative consequences for not adhering to social, familial, or ethical norms
- Rigid morality, leading to judgmental attitudes or a lack of forgiveness
- Taking on too much responsibility for others' well-being, neglecting your own needs in the process

My Notes:

GATE 51

The Gate of Shock	Aries	Sudden Changes, Transformation, Unexpected Events
-------------------	-------	---

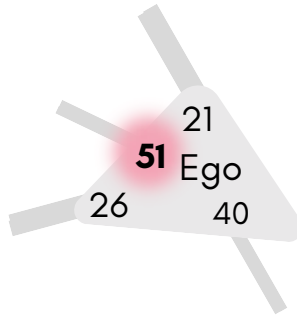

Higher Expressions of Gate:

- Embodying the energy of enlightenment
- Spiritual awakenings through unexpected life events that, while initially shocking, lead to profound inner growth and enlightenment
- Courage and fearlessness to face the unknown with bravery, trusting in the journey, and embracing change
- Leading by example in embracing change and transformation

Lower Expressions of Gate:

- Disruption and chaos that seem to have no purpose or direction
- A sense of being perpetually off-balance
- Competitiveness that borders on conflict
- A sense of constant upheaval
- An ego-driven desire to be the best, sometimes at the expense of others or one's own well-being
- Resistance to change, resulting in a cycle of stagnation

My Notes:

GATE 52

The Gate of Stillness	Cancer	Stillness, Concentration, Meditation
-----------------------	--------	---

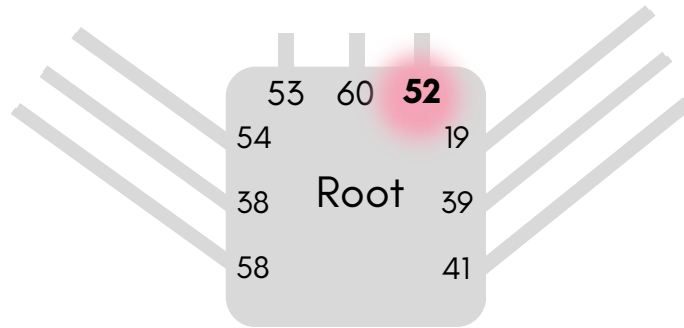

Higher Expressions of Gate:

- Serenity and stability, like the serene summit of a mountain, where the chaos of the world below seems distant, and clarity abounds
- Being a master of maintaining inner calm, regardless of external circumstances
- Understanding that true wisdom comes from a place of stillness, where the mind is clear, and the soul is attentive
- The capacity to gain profound insights and understandings from a place of stillness
- Actions taken deliberately, informed by deep contemplation

Lower Expressions of Gate:

- Stagnation/inertia, like a mountain that, while majestic, blocks the path forward
- An excessive focus on contemplation, resulting in indecision and a failure to act when necessary
- Isolation/disconnection from the world and others

My Notes:

GATE 53

The Gate of Beginnings	Cancer	Initiation, Pressure, Expansion
------------------------	--------	---------------------------------

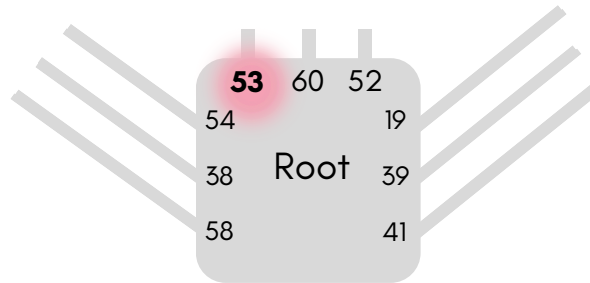

Higher Expressions of Gate:

- Innovative thinking and creativity, where you see possibilities where others see challenges
- Embracing the fluid nature of beginnings
- Ability to adapt to changes and new circumstances, making the most of emerging opportunities
- Optimism and enthusiasm for new ventures
- Thoughtful planning and consideration of the steps required for successful outcomes

Lower Expressions of Gate:

- Impulsiveness/starting new projects or jumping into new situations without adequate planning, leading to unfinished initiatives and dissatisfaction
- Fear of change or an inability to let go of the past
- Resistance to seeing projects through to the end, leading to a pattern of starting many things but finishing few

My Notes:

GATE 54

The Gate of Drive	Capricorn	Pressure to Act & Ascend, Ambition, Determination
-------------------	-----------	--

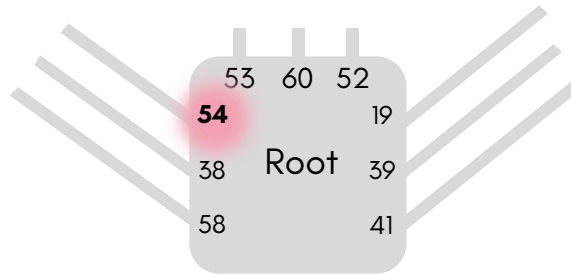

Higher Expressions of Gate:

- Pursuing goals with integrity, where the means are as important as the ends
- Balanced ambitions, where spiritual and emotional dimensions are just as important as material success
- Using position and power to assist others in their ascent, fostering a community spirit and collective upliftment

Lower Expressions of Gate:

- Unchecked ambition, leading to behaviors driven by greed, manipulation, or a ruthless pursuit of success
- Using others for personal gain
- Overemphasis on status and material achievements
- Ignoring emotional and spiritual needs

My Notes:

GATE 55

The Gate of Spirit	Pisces	Emotional Waves, Deep Feelings, Spiritual Insights
--------------------	--------	--

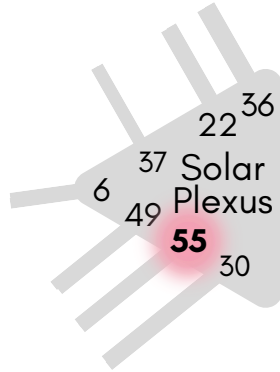

Higher Expressions of Gate:

- Emotional wisdom to ride any emotional waves with grace, understanding that feelings are transient and not always reflective of true reality
- A recognition that true abundance comes from within, leading to a sense of fullness and satisfaction that is independent of external conditions
- Deep spiritual connection
- Ability to channel intense emotional energy into creative pursuits

Lower Expressions of Gate:

- Emotional overwhelm and intense emotional swings
- Fear of scarcity and a focus on what's lacking rather than what's available
- Feeling like your sense of abundance is heavily tied to external factors, such as relationships, wealth, or status
- Difficulty communicating emotions

My Notes:

GATE 56

The Gate of Stimulation

Cancer/Leo

Storytelling, Imagination,
Expression

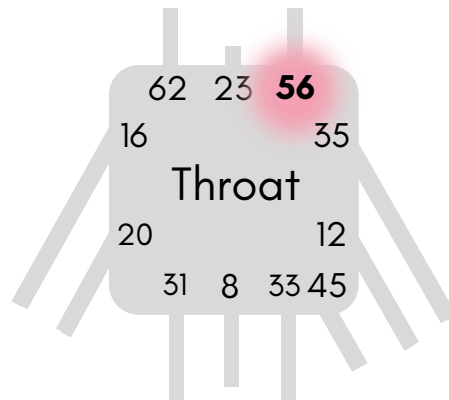

Higher Expressions of Gate:

- Using storytelling skills to inspire and move others
- Ability to weave complex ideas into accessible narratives that can motivate, teach, and connect emotionally with people
- Open-minded exploration of cultures, ideas, and philosophies
- Using your idealistic visions to drive positive changes and pursue ventures that have a meaningful impact on society
- Empathetic expression

Lower Expressions of Gate:

- Desire for constant stimulation, resulting in a lack of focus and jumping from one idea or project to the next
- A pattern of unfulfilled intentions and persistent restlessness
- Embellished narratives or unrealistic expectations
- Manipulating narratives to fit personal biases or agendas

My Notes:

GATE 57

The Gate of Intuitive Insight	Libra	Intuitive Hearing, Inner Knowing, Instinct
-------------------------------	-------	--

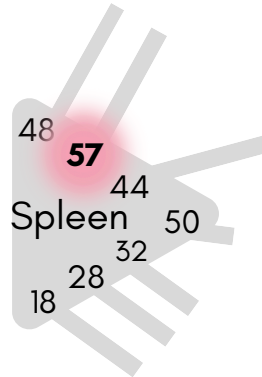

Higher Expressions of Gate:

- Clear, often uncanny ability to perceive the truth in a situation, foresee potential outcomes, and navigate life with confidence in your inner guidance
- The sensitivity to understand others at a deep emotional level
- Using instincts to protect yourself and others from harm, where you anticipate problems before they arise and take preventative action
- A balanced sense of caution that aids in decision-making without being hindered by fear or anxiety

Lower Expressions of Gate:

- Paralyzing fear of potential negative outcomes, causing inaction or constant anxiety
- A tendency to over-rely on your instincts, which can sometimes turn into suspicion towards others' intentions, leading to isolation or conflict
- Hypersensitivity to the environment or other people's emotions
- Obsessive worrying

My Notes:

GATE 58

The Gate of Vitality	Capricorn	Joy, Vitality, Improvement
----------------------	-----------	-------------------------------

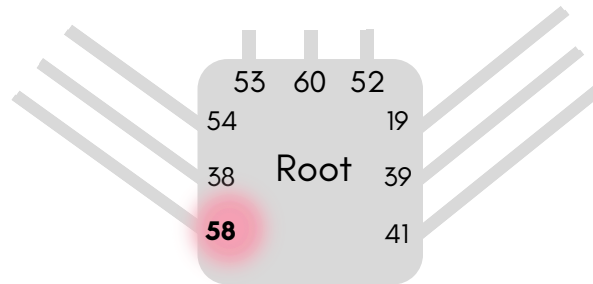

Higher Expressions of Gate:

- Deep-seated joy
- Ability to identify what needs enhancement but do so in a way that uplifts rather than criticizes
- Authentic zest for life
- The desire for improvement is balanced with an appreciation for the way things are

Lower Expressions of Gate:

- Perpetual dissatisfaction where nothing ever seems good enough
- Compulsive need for improvement, rarely finding joy in accomplishments
- Focusing too intensely on what could be better, resulting in a less fulfilled life

My Notes:

GATE 59

The Gate of Sexuality	Virgo	Intimacy, Sexuality, Togetherness
-----------------------	-------	--------------------------------------

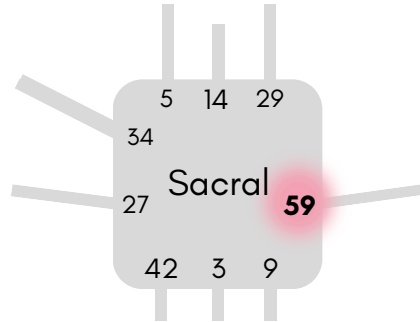

Higher Expressions of Gate:

- Being adept at forming meaningful, soulful connections
- Harmonious relationships that overcome differences and find common ground
- Transformation through intimate relationships
- Inclusivity and acceptance

Lower Expressions of Gate:

- Fear of not being accepted or loved, leading to either an avoidance of intimacy or a desperate need for it
- Disregarding personal boundaries from a desire for closeness, leading to codependency
- Poor communication and misunderstandings, leading to conflicts and strained relationships
- Resistance to the transformative aspects of relationships, leading to stagnation and missed opportunities for growth

My Notes:

GATE 60

The Gate of Acceptance	Capricorn/Aquarius	Limitations, Evolution, Transformative Pressure
------------------------	--------------------	---

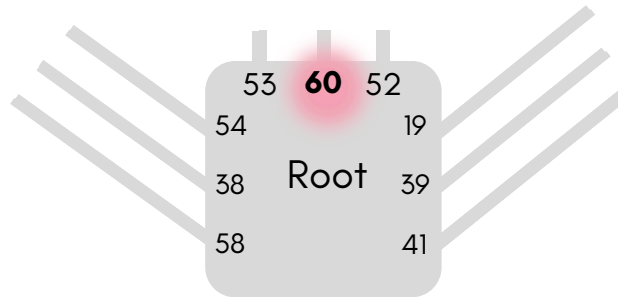

Higher Expressions of Gate:

- Seeing constraints as catalysts for growth, creativity, innovation, and the development of resilience
- Embracing limitations as a way to find unique pathways to achieve your goals
- Recognizing that meaningful change takes time and that patience is crucial when navigating challenges

Lower Expressions of Gate:

- Being overwhelmed by limitations and constraints
- Being fixated on obstacles
- Resistance to change/tendency to cling to the familiar, even when it's no longer serving, due to fear of the unknown or perceived risks involved in stepping beyond established boundaries
- Pessimism/Viewing limitations as permanent fixtures, leading to a defeatist attitude towards challenges and a reluctance to pursue novel solutions
- Impatience/A desire for immediate results, which can lead to rash decisions or actions

My Notes:

GATE 61

The Gate of Mystery	Capricorn	Inner Truth, Pursuit of the Unknown, Mental Pressure
---------------------	-----------	--

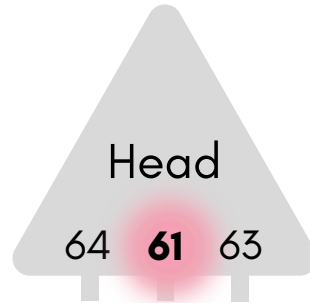

Higher Expressions of Gate:

- Wisdom, intuition, and a profound connection to universal truths
- Intuitive knowledge/just 'knowing' things without knowing how or why
- Ability to ponder deep questions about life, existence, and the universe with a clear-minded approach
- Spiritual connection
- Inspiring others through thoughts and insights

Lower Expressions of Gate:

- Obsessive quest for answers
- Persistent thinking about existential questions without finding peace or answers
- Mental strain, where the mind struggles to switch off
- Delusional beliefs
- Isolation due to thoughts being consumed by unsolvable puzzles or being misunderstood by others

My Notes:

GATE 62

The Gate of Details	Cancer	Precision, Details, Communication
---------------------	--------	-----------------------------------

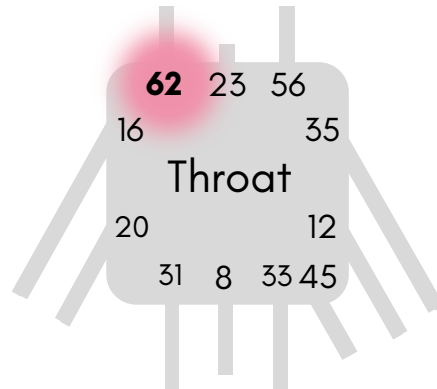

Higher Expressions of Gate:

- Precision in communication, fostering a clear and effective exchange of ideas
- Ability to articulate complex concepts in an accessible manner
- Ability to use the power of details to enhance understanding
- Connection through communication
- Innovative solutions and breakthroughs through details

Lower Expressions of Gate:

- Analysis paralysis from being overly focused on details
- Overthinking, where the fear of imperfection or misunderstanding prevents effective communication
- Miscommunication when the desire for precision leads to overly complex explanations that confuse rather than clarify
- Isolation due to prioritizing details over the essence of connection

My Notes:

GATE 63

The Gate of Doubt	Pisces	Logic, Skepticism, Questions
-------------------	--------	---------------------------------

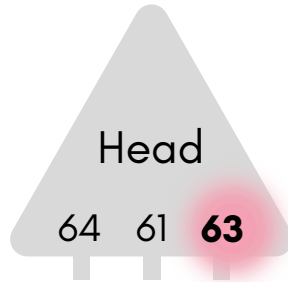

Higher Expressions of Gate:

- Constructive questioning that leads to deeper understanding and insights
- Ability to analyze situations logically
- Advancement of collective knowledge
- Balanced skepticism
- Mental resilience, leading to the ability to navigate uncertainty with a more grounded and calm approach

Lower Expressions of Gate:

- Excessive doubt and skepticism that hinders decision-making
- Constant questioning and the need for proof, leading to mental exhaustion and anxiety
- Cynicism/a jaded outlook on life
- Isolation due to incessant questioning and doubt

My Notes:

GATE 64

The Gate of Confusion	Virgo	Pressure to Make Sense of the Past, Clarity, Creative Breakthroughs
-----------------------	-------	---

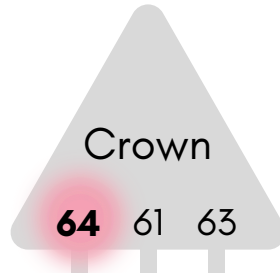

Higher Expressions of Gate:

- Ability to embrace the chaotic nature of thoughts and find patterns and meanings not initially apparent
- Ability to connect disparate ideas in innovative ways, leading to creative breakthroughs
- Clarity from reflection, instead of being overwhelmed by memories or ideas
- Ability to be comfortable with uncertainty and open to possibilities without needing immediate resolution

Lower Expressions of Gate:

- Confusion/mental fog
- Feeling lost in a sea of unconnected thoughts and memories, unable to find a way to sort through them meaningfully
- Mental paralysis, decision fatigue, inability to focus on what is important
- Anxiety over the unknown
- Dwelling on the past, stuck in a loop of what-ifs and should-haves

My Notes:



***Thank you so
much for your
purchase!***

**For more Human Design
tips, follow us on
Instagram! ➡**