

KITCHEN PAVILION

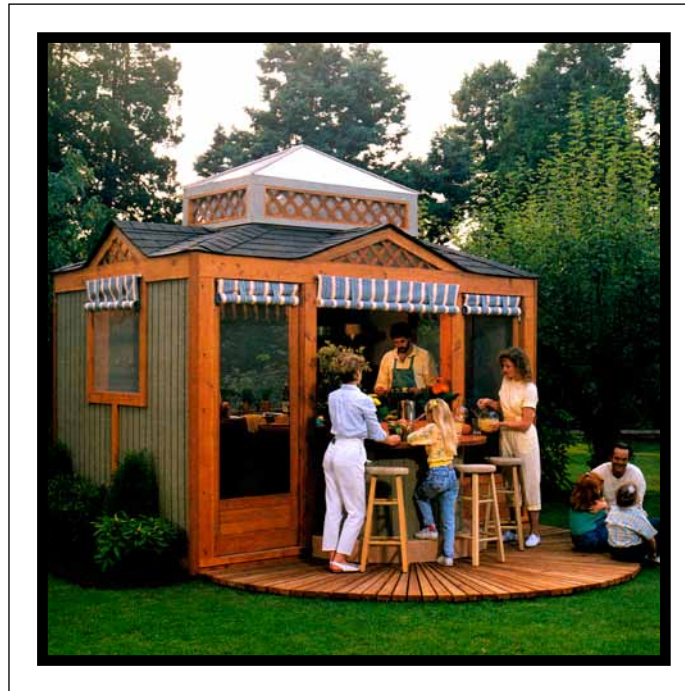

KITCHEN PAVILION

The kitchen pavilion, with its smooth tile floor, paneled interior and high cupola roof, is the perfect backyard room addition. It is designed to hold everything a gourmet cook needs: a refrigerator, cupboards, shelves, a sink and over 14 feet of counter space for extensive food preparation. This 8- x 12-foot do-it-yourself kitchen unit is sheathed in APA Texture 1-11 plywood siding, and fully trimmed for a professional, finished appearance. An attractive semi-circular, 6- x 12-ft Redwood deck, featuring an outdoor bar, expands both the size and efficiency of the pavilion.

For people who love to cook, the kitchen pavilion provides all the conveniences of an indoor kitchen, without the cramped, stuffy feeling of cooking inside. All windows and doors are screened for exceptional air circulation, with a removable front window option for easy serving capability. This project is recommended for advanced do-it-yourselfers. Experienced builders can creatively add or subtract features to customize the kitchen.

MATERIALS LIST

FLOOR CONSTRUCTION

QUANTITY	MATERIAL	APPLICATION
5 pieces	4-inch x 6-inch x 8-ft treated lumber	floor base
124 lin. ft	2x4 treated lumber	floor framing
3 sheets	3/4-inch x 4-ft x 8-ft tongue-&-groove APA Rated Sturd-I-Floor	floor
As needed	16d galv. nails	floor framing
As needed	8d ring- or screw-shank nails	floor

WALL CONSTRUCTION

QUANTITY	MATERIAL	APPLICATION
660 lin. ft	2x4 (8-ft, 10-ft, & 12-ft)	wall & roof framing
7 sheets	5/8-inch or 19/32-inch x 4-ft x 8-ft APA 303 Siding (T1-11)	outside walls
7 sheets	3/8-inch x 4-ft x 8-ft APA 303 Siding (rough sawn)	inside walls
As needed	16d galv. nails	wall framing
As needed	8d nonstaining box, siding or casing nails	outside walls
As needed	6d galv. box nails	inside walls

ROOF CONSTRUCTION

QUANTITY	MATERIAL	APPLICATION
6 sheets	1/2-inch x 4-ft x 8-ft APA Rated Sheathing	roof & bar tile base
4 sheets	3/8-inch x 4-ft x 8-ft APA 303 Siding (rough sawn)	inside roof
3 rolls	4- x 6-ft screen	windows, vents, cupola
1	removable screen (opt.)	front window
2 pieces	2-inch x 2-inch x 10-ft flashing	outside main roof/cupola joints, on top of roofing
2 squares	roofing	
1 roll	15 lb. roofing felt	
2 pieces	1/8-inch clear plastic 30-inch x 72-inch	cupola
2 pieces	1/8-inch clear plastic 48-inch x 48-inch	cupola
2 pieces	4x8 lattice work	lattice
As needed	16d galv. nails	roof framing
As needed	6d box nails	roof sheathing
As needed	roofing nails	

TRIM

(some lengths are nominal, some need to be ripped)

QUANTITY	MATERIAL	APPLICATION
98 lin. ft	3/4- x 4-5/8-inch	window & door wrap
32 lin. ft	3x3 corner	outside corners
48 lin. ft	1x8	top of outside walls
16 lin. ft	3/4- x 5-1/8-inch	outside door trim next to corners
169 lin. ft	1x4	outside windows, botom of outside walls, inside windows, & outside cuplola & lattice
32 lin. ft	3/4- x 4-3/8-inch	outside & inside between doors & front windows
16 lin. ft	3/4- x 4-1/2-inch	inside wall/roof joint at building ends
24 lin. ft	3/4- x 5-inch	inside wall/roof joint at building front & back
50 lin. ft	1/4- x 3/4-inch screen molding	inside cupola joints
70 lin. ft	1- x 1-inch corner trim	outside, on top of platic & inside at top of roof joints
114 lin. ft	3/4- x 1-3/4-inch pine (ripping from larger pieces of trim)	inside door & cupola lattice
As needed	6d or 8d galv. finish nails	all trim

MISCELLANEOUS

QUANTITY	MATERIAL	APPLICATION
150 sq. ft	6- x 6-inch floor tile (opt.)	floor & bar foot rest
2	32- x 81-inch screen doors	
2 pair	4-inch double acting door hinges	screen door
As needed	staples (& gun)	screen

CONSTRUCTING DECK AND BAR

QUANTITY	MATERIAL	APPLICATION
1 sheet	5/8-inch x 4-ft x 8-ft APA 303 Siding (T1-11)	curved bar front
200 lin. ft	2x4 common Redwood	deck
35 lin. ft	2x4 treated lumber	framing under deck
As needed	timbers or blocks	under deck
60 lin. ft	2x4 clear Redwood	bar top
As needed	10d nonstaining galv. nails	nailing deck from behind
As needed	12d galv. or casing nails	nailing deck from front

CABINET AND SHELVES

Construct the following:

QUANTITY	MATERIAL	APPLICATION
1	60- (W) x 36- (H) x 24-inch (D)	cabinet assembly under front window
1	36- (W) x 36- (H) x 24-inch (D)	left back corner cabinet
2	1-1/2- (W) x 36- (H) x 24-inch (D)	partition next to sink for refrigerator
2	13- (W) x 45-1/2- (H) x 12-inch (D)	upper cabinets
4	24- (W) x 3/4- (H) x 12-inch (D)	adjustable shelves
1	24- x 60-inch	front counter top
1	24- x 136-1/2-inch	back counter top

Use these materials:

QUANTITY	MATERIAL	APPLICATION
6 sheets	3/4-inch A-C plywood	cabinets, partitions, shelves, counter tops, bar top & bottom, & drawer faces
1 sheet	1/4-inch x 4-ft x 8-ft A-C plywood	drawer bottoms & cabinet backs
1 sheet	1/2-inch x 4-ft x 8-ft A-B plywood	drawer sides
6 sets	20-inch drawer guides	
10	handles (pulls)	drawers & cabinets
As needed	screws	cabinets to wall connection

FINISHING

QUANTITY	MATERIAL	APPLICATION
As needed	paint or stain	outside walls, inside walls, & trim
As needed	deck seal	deck
As needed	exterior varnish	bar top

PROJECT NOTES

Before You Start Building:

Read the entire set of building directions and study the diagrams before you start building. Build one section of the kitchen pavilion at a time; as you build, you may need to adjust your measurements slightly to compensate for misalignment. And do not throw away plywood or lumber scraps; you will need them later.

Check your local building codes to make sure you can construct the kitchen pavilion without a building permit.

Be sensible; take safety precautions. When using power tools, wear safety goggles to protect your eyes from splinters and dust. Always follow the tool manufacturer's recommendations.

Preparing the Site and Foundation:

Select a suitable site for your kitchen pavilion. Make sure the area is level, then lay down your foundation. A gravel foundation is easiest; just dig out 3 inches of soil, replace with gravel, level and pack. You may also use a concrete slab or concrete blocks.

Floor Construction:

Lay treated 4x6s flat on the gravel foundation, 36 inches on center. Then place treated 2x4s on edge, 16 inches on center, perpendicular to and on top of the 4x6s. Use two 2x4s, nailed together, on the long outside framing edges. Before

nailing, check again to ensure that your foundation is level by setting a straight 2x4x12' across all the 4x6s.

Cover the floor framing with 3/4-inch APA STURD-I-FLOOR tongue-and-groove panels, making sure the long dimension runs perpendicular to the 2x4s. Do not push the T&G edges together completely; leave a 1/8-inch space at all edge joints to allow for panel expansion. Use 8d ring- or screw-shank nails every 6 inches along panel edges and every 12 inches at intermediate supports. If you intend to cover the floor with tile, consult the tile manufacturer for additional nailing schedule.

When you have completed the floor, read ahead. You may want to construct the walls, roof and deck on this flat, smooth surface.

Wall Construction:

Construct wall frames on a flat surface, such as a workshop floor or the pavilion floor. Lay out end walls first; they will be identical, except at the doors. See Figure 5 on page 11 for door detail. Space vertical framing 16 inches on center. Add additional framing for windows as shown (see Figures 2, 3 and 4 on page 10).

You can apply 5/8-inch APA T1-11 siding to each wall frame after you construct it (while it is still laying on a flat surface), or you can apply the siding to the frames after you have constructed and erected all four walls. Do not, however, apply siding to the top of the front wall

frame until *after* the roof is installed. Nail siding every 6 inches on panel edges and every 12 inches on intermediate supports, using 8d nonstaining box, siding or casing nails. Be sure to cut out spaces for windows and doors before cutting and nailing the siding to the frames. Make sure the laps are correctly positioned. Siding should extend 3-1/2 inches past the top of each wall frame. This will eventually allow you to secure the roof to the walls.

To erect walls, set one end wall in place and brace it with 2x4s. Nail it to the floor with 16d galvanized nails, angled so they penetrate the outboard joist. Set the back wall, then other end wall in place, nailing to the floor joists and to each other. Lastly, set the front in, nailing it to the floor and ends. Remember, you will use the rippings from the walls to fill in the spaces above the windows, along the sides of the doors, and on the lower half of the front and back windows, so be sure the plywood edge laps are positioned correctly.

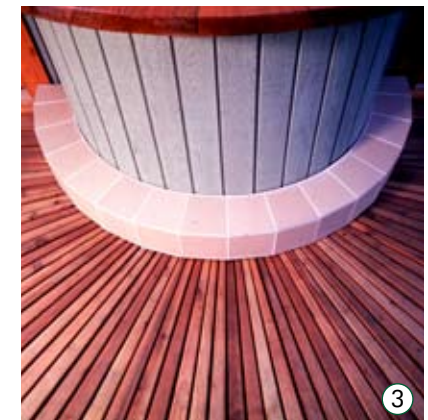
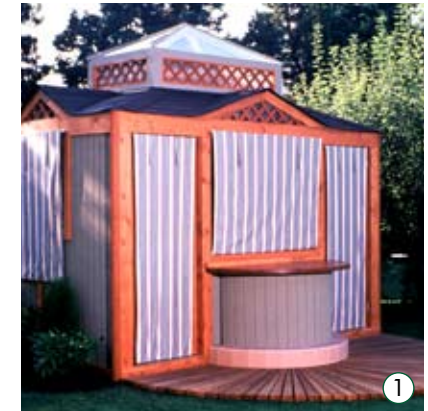

Top to Bottom: 1. Decorative roll-up shades add color and privacy to the kitchen pavilion. 2. The interior space measures 96 square feet, enough for two or more people to help with food preparations. 3. Redwood decking and a tiled bar footrest are just one of many options to complete the finished look.

Roof Construction:

The roof is constructed in two sections – the main roof and the cupola. Pre-assemble both parts on a flat, level surface before installing on the pavilion.

STEP 1. CONSTRUCT THE MAIN ROOF.

Before you begin, you may need to slightly adjust the angles of the 2x4 roof rafters (see Figure 8, pieces A through I on page 12). Cut these pieces a little long the first time, then double check the measurements, as lumber can vary slightly. Double frame the outside edges of the main roof, making sure it's square. Construct three 71- x 45-inch rectangle frames; one will be the center of the main roof, and two will frame the cupola. To achieve a center roof height of 16 inches, set the center frame of the main roof on 16-inch blocks, then nail rafters to connect the outside and center portions of the main roof (see Figure 8). Corner rafters A, B and G are notched to fit over the outside frame. Nail those first, then construct vents (C and D), nailing them together at the ridge, then to the frame. Then nail ridges, valleys, and supports (H, I, E and F). Measure, cut and fit roof sheathing, but do not nail yet.

With the help of some friends, lift roof frame onto walls. Nail to wall framing and siding. Now install the rest of the 5/8-inch T1-11 siding on the outside, along the window and door openings.

STEP 2. CONSTRUCT THE CUPOLA. To construct the cupola, notch 2x4s, insert and nail to upper and lower framing and to other 2x4 supports. The notched 2x4s at

each corner will extend 2 inches below the lower portion of the cupola (see Figure 11 on page 13); this will enable you to later slip the cupola over the main roof and nail securely. Nail framing members (Js first, then cut Ks to fit) to complete the cupola peak. Set cupola on main roof and nail. You may want to cover the cupola with a tarp until you can complete it.

Apply 1/2-inch sheathing to outside of main roof (see Figure 12). Nail panel pieces in the following sequence: all 3s first, then 1s, then 2s and 4s. Space 6d box nails every 6 inches at edges and at intermediate supports.



APA's Kitchen Pavilion is an ideal backyard upgrade combining a full kitchen and entertainment focal point into one do-it-yourself project.

Finishing Walls and Roof:

(See Figures 16, 17 and 18 on pages 15-16)

(Complete in the following sequence)

1. Apply 3/8-inch APA 303 Plywood Siding to inside walls. Lay out and check dimensions before cutting. Do not forget to position half laps correctly. Cut openings for windows and doors before applying siding.

2. Paint outside and inside walls. For later convenience, you may also want to paint the trim pieces.

Calculate how much material you will need for the trim; odd-sized trim pieces can sometimes be ripped from larger pieces, with some left over for the shorter (1-3/4-inch) trim requirements.

3. Apply window and door wrap.

4. Staple screens on the outside of back and end wall window openings. You may want to install a removable screen for the front window, so you can pass things from the kitchen directly to the outside bar.

5. Apply corner trim to all four outside corners (see Figure 13 on page 14).

6. Apply 1x8 trim along the top of the outside walls.

7. Apply 1x4 trim along the bottom of the outside walls.

8. Apply outside door and window trim (see Figure 14 on page 14).

9. Finish outside of main roof: Nail or staple roofing paper to sheathing. Then lay down roofing, starting from the bottom edges, fitting and nailing as you go. Consult roofing manufacturer for specific application recommendations. The roofing will extend 1- to 1-1/2-inch over the edge of the wall trim.

10. Apply screens to main roof and cupola in-vents from the inside of the pavilion. Staple in place.

11. Line the inside of the main roof with 3/8-inch APA rough-sawn plywood. Cut, locate and nail pieces in the following order: M, L, P, N and O (see Figure 15 on page 15). Be sure the half laps on M and L pieces fit together; cut one pair at a time. Nail with six penny casing, box or finish nails. Use scrap 3/8-inch rough-sawn plywood for inside cupola, top and bottom trim.

12. Paint the 3/8-inch plywood inside the roof.

13. Apply 4-1/2-inch and 5-inch trim to inside wall/roof joint.

14. Trim around inside windows (except back window) and doors.

15. Trim inside vertical corners on the main roof and cupola.

16. Apply 1x1 trim to inside horizontal cupola/main roof joints.

17. Apply 1x4 trim to sides and top of cupola and lattice screens.

18. Apply 2x2 flashing to outside main roof/cupola corner joints.

19. Apply 2-inch trim to lower outside part of cupola over flashing.

20. Stain lattice work and apply to cupola and main roof vents from outside the pavilion (see Figures 19 and 20 on page 17).

21. Install 3/4- x 1-3/4-inch stops around lattice on cupola, and apply trim around lattice on main roof vents.

22. Paint cupola.

23. Cut clear sheet plastic for cupola skylight (see Figure 21 on page 17). Drill the plastic where it meets the cupola frame, then secure with stainless steel screws. Trim outside cupola plastic joints with 1x1 corner pieces.

Install Tile Floor:

Follow tile manufacturer's recommendations for proper installation. You do not need to fully tile the floor; you can leave spaces under counters and cupboards untiled.

Install Screen Doors:

(follow manufacturer's recommendations).

Cover Windows and Doors with Drapes:

(optional).

Constructing the Deck:

Rip Redwood deck pieces on a table saw, using a 3/4-inch plywood jig as a guide (see Figure 22 on page 17). Use treated 4x6s or gravel as a base. Construct the deck on a flat, clean surface, such as the floor of the pavilion before the walls are installed. Lay all deck pieces face down and lay treated 2x4 framing over them. Nail, angling nails so they do not penetrate the surface. Use at least two nails in each framing board for a stable, solid deck. If you nail from the front, use 12d galvanized casing nails, angling nails so they do not extend beyond the framing. Allow a 5/8-inch space between the Redwood pieces around the outside edge, and 1/16 inches inside, approximately 16 inches from the center point. Use exterior deck seal on the Redwood to ensure a long-lasting durable finish.

Constructing Bar:

Construct the 2x4 frame, using lumber and 3/4-inch plywood. Cut the 5/8-inch T1-11 to a length of 34-1/2 inches. Saw-kerf 1/2-inch grooves along the inside of the 5/8-inch APA T1-11 siding piece, making sure not to kerf in the same location as a groove (see Figure 30 on page 19 for close-up detail). Bend the siding to fit the plywood bar frame, nailing siding to vertical supports and to the plywood base as you bend. Nail from center outward. Construct and apply bar top, then set bar base on the Redwood deck. Or attach to deck and front wall with fasteners. To construct the tile footrest around the bottom of the bar, nail 5-inch 2x6 blocks to 1/2-inch sheathing top and bottom pieces (see Figure 31 on page 19 for block placement). Bend a 1/4-inch plywood ripping for the front of the footrest; secure. Glue shims onto 1/4-inch plywood so the tile can be glued to the front of the footrest in three places (see Figure 32 on page 19). Apply tile to the front and top, using exterior glue. Top tile will be 1/4-inch short; fill in extra space with grout. Be sure to follow tile manufacturer's recommendations.

If you do not wish to use tile, you may cover the bar footrest with wood. Use kerfed, banded T1-11 plywood around the front and band-saw 2x12s to fit the top of the footrest, leaving a slight overhang.

Counter and Cabinets:

(against back and front walls)

Cut partitions and face frames for 36- and 60-inch cabinets. Face frames can be 1x2s or 3/4-inch plywood rippings. Dado partitions at shelves only, then lay partitions on edge and glue and nail shelves. Use finish nails on ends and six penny box nails inside. Dowel and glue all face frames to cabinets. Apply drawer hardware, then apply cabinet backs and 1/4-inch A-C in back of the drawers. Sand and paint or apply plastic laminate, then position cabinets in their proper locations. Custom cut the hole for your sink, adding plastic laminate to top and edges of counter if desired. Cut hole for grill, if desired. Our electric grill is shown in the photo. If you use a propane gas grill instead, enlarge the side windows so that at least 50 percent of the building is open. (This is required by the National Fire Prevention Association Code.) Screw on counter top from underneath at partition cleats.

Constructing Drawers:

Rip and cut to length 1/2-inch APA A-B plywood for drawer sides, fronts and backs. Cut 1/4-inch APA A-C plywood for drawer bottoms. Nail the sides, front and back together first, then the bottom. Sand, then apply your choice of drawer finish and hardware.

Corner Shelves:

Cut shelves and corner back pieces. Apply plastic laminate before assembling, if desired, or paint after assembling. Rip face frames, then nail together end and back pieces. Nail shelves in their appropriate positions (see Figure 40 on page 21). Apply face frames. Drill holes in assembly for adjustable shelves, then line up the shelves and drill holes in the wall so shelves will be straight. Screw assembly to back wall.

To finish the kitchen pavilion, trim around back window, ripping pieces to size (approximately 3/4- x1-inch).



The Kitchen Pavilion offers more than 14 feet of counter space.

PANEL LAYOUTS

(unless otherwise specified, cut one of each panel layout)

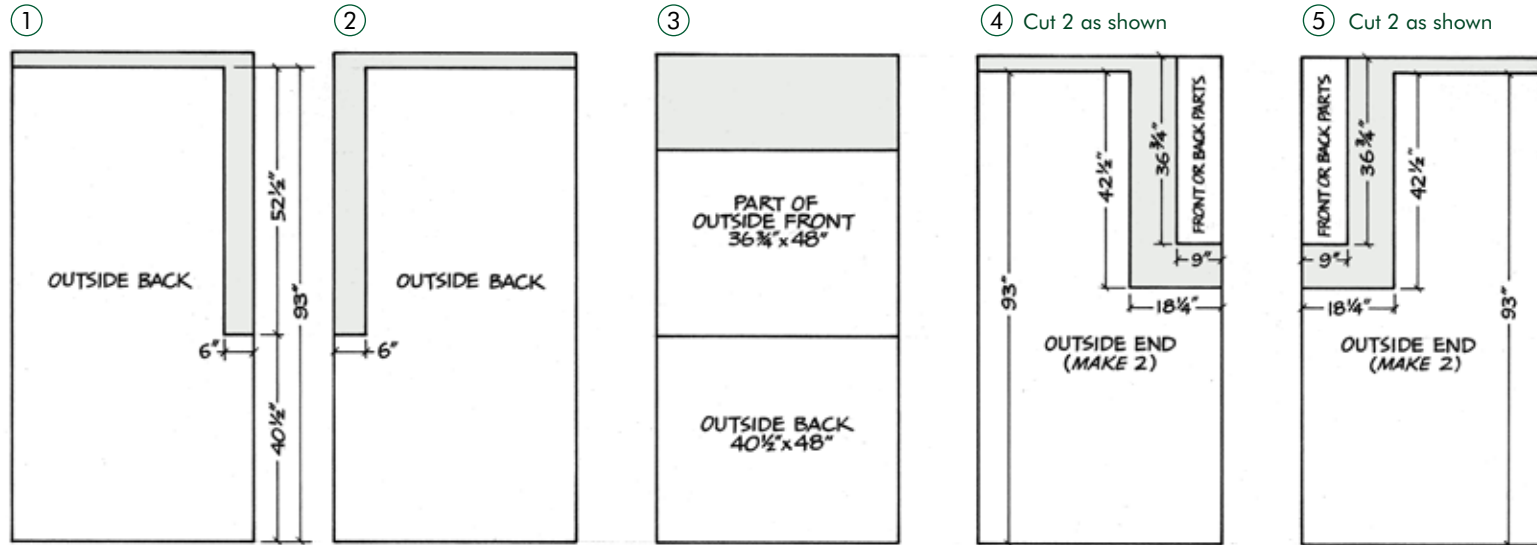

Panels 1-5: 5/8" APA 303 Siding (T1-11)

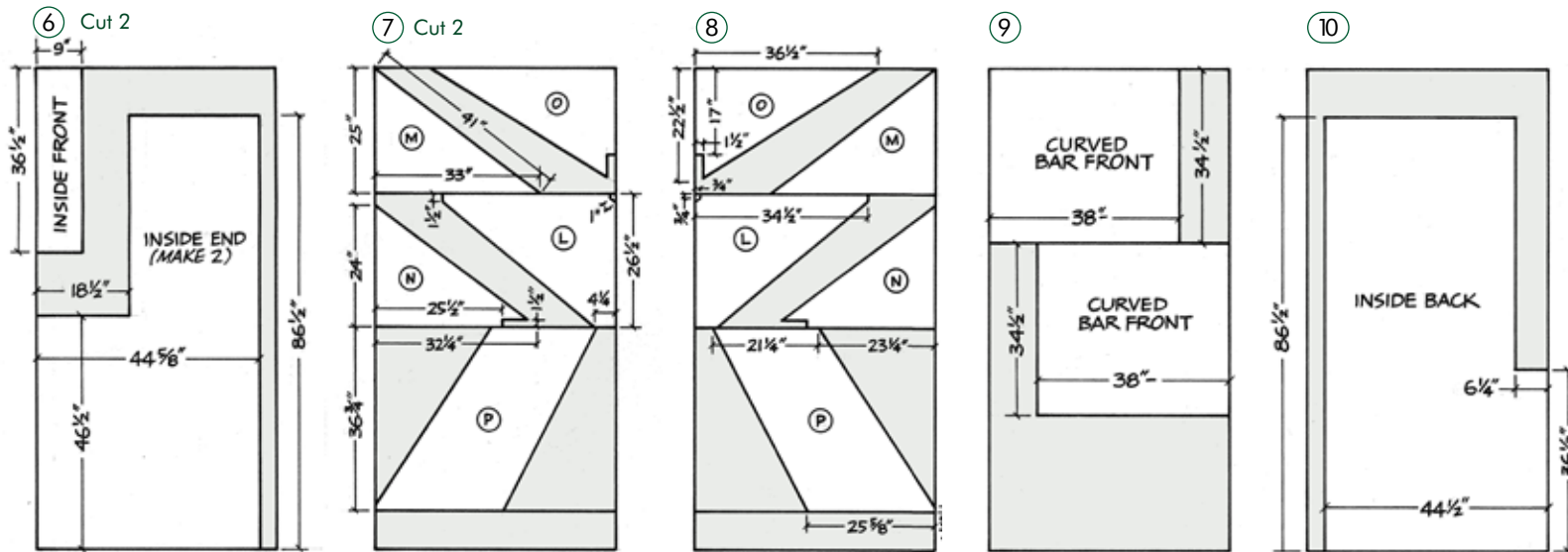

Panels 6-8: 3/8" APA 303 Siding (rough sawn)

Panel 9: APA 303 Siding (T1-11)

Panels 10-13: 3/8" APA 303 Siding (Rough sawn)

PANEL LAYOUTS

(unless otherwise specified, cut one of each panel layout)

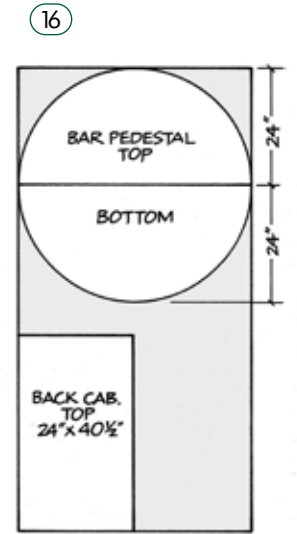
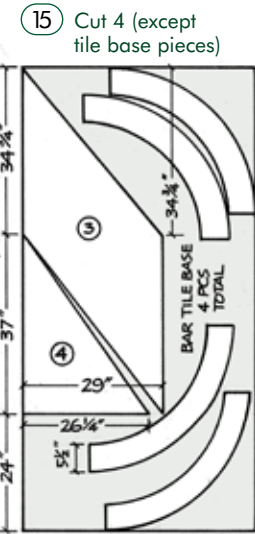
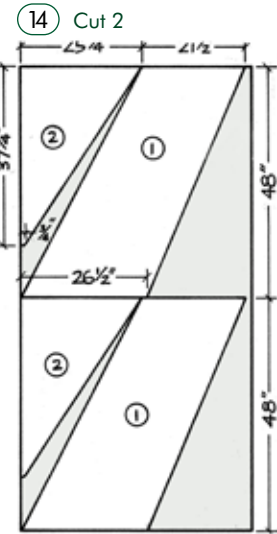
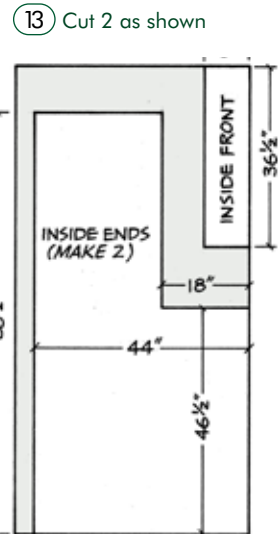
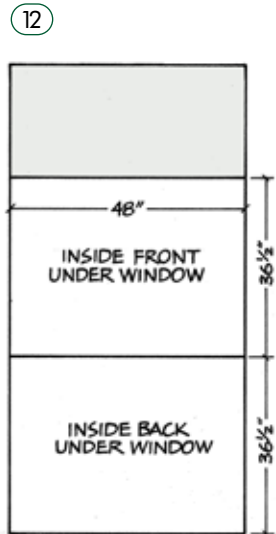
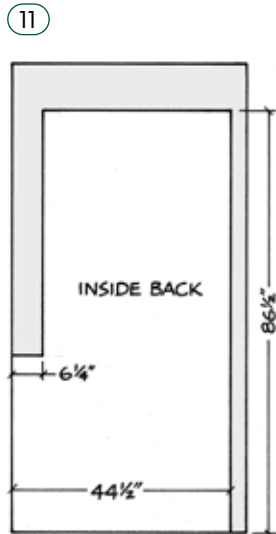

Panels 14-15: 1/2" APA Rated sheathing

Panel 16: 3/4" APA A-C Plywood

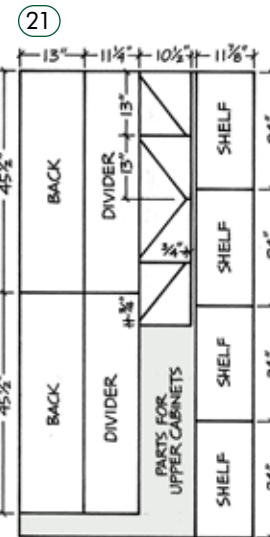
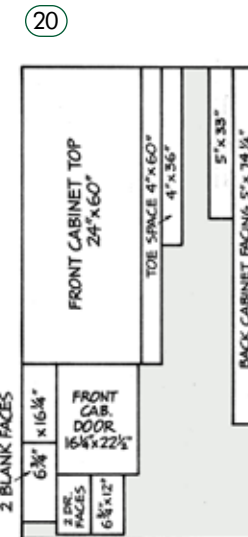
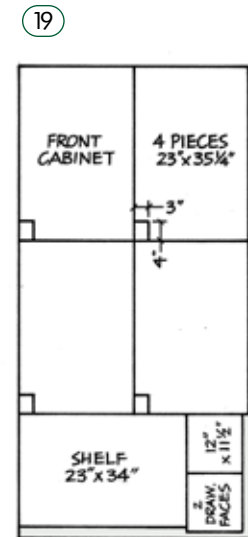
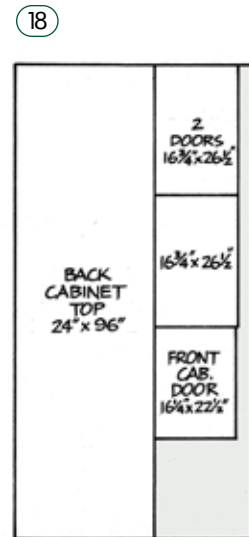
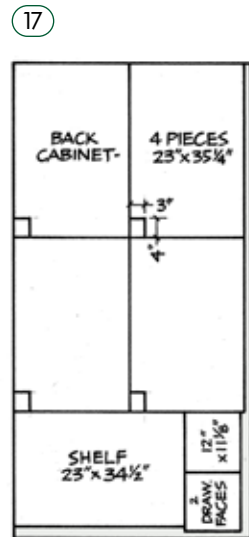

Panels 17-21: 3/4" APA A-C Plywood

Not Shown:

3 sheets of 3/4" APA Rated Sturd-I-Floor.

1 sheet of 1/4" APA A-C Plywood for drawer bottoms and cabinet backs.

1 sheet of 1/2" APA A-B Plywood for drawer sides.

FIGURE 1
Floor Construction

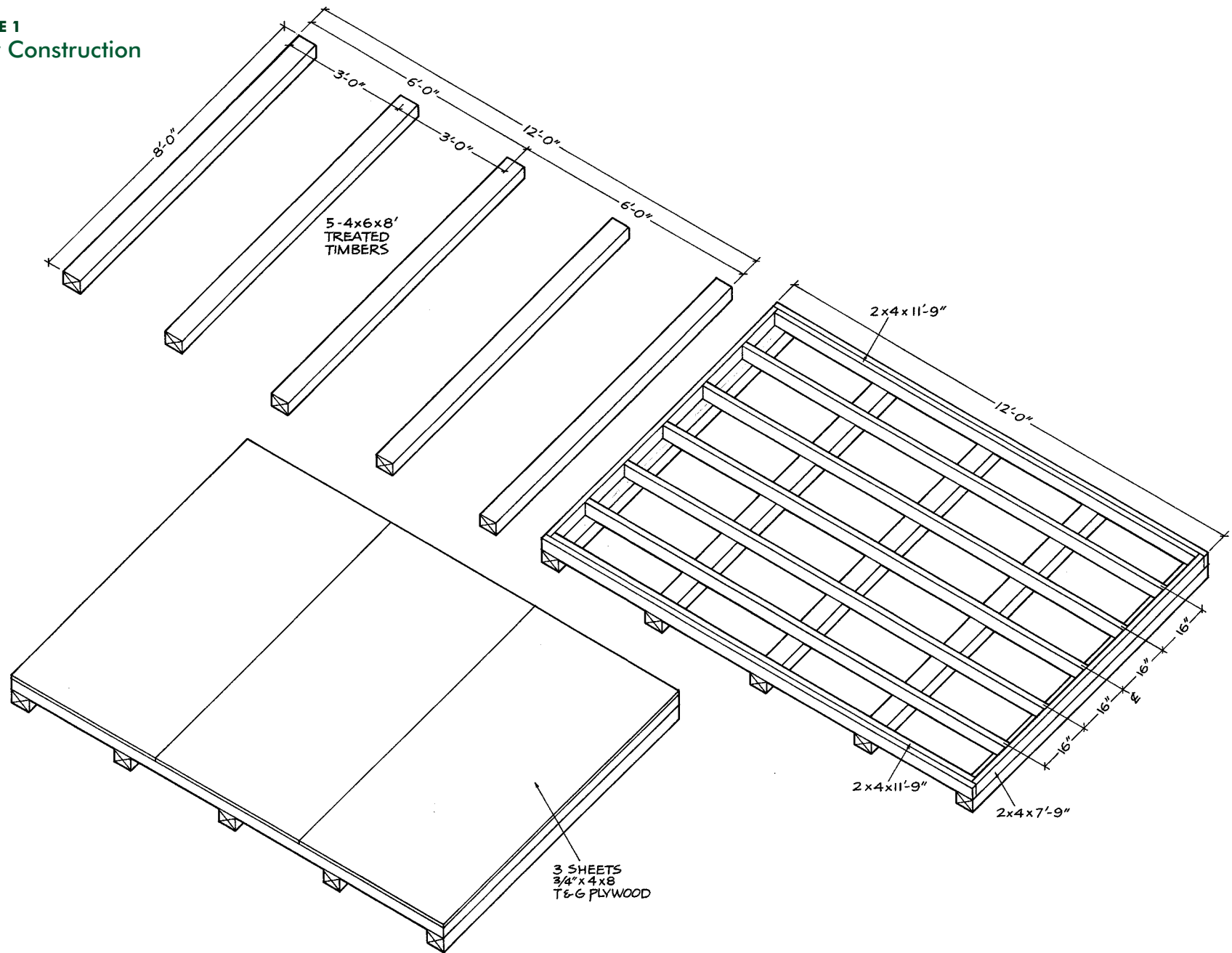

FIGURE 2
Wall Framing, Back

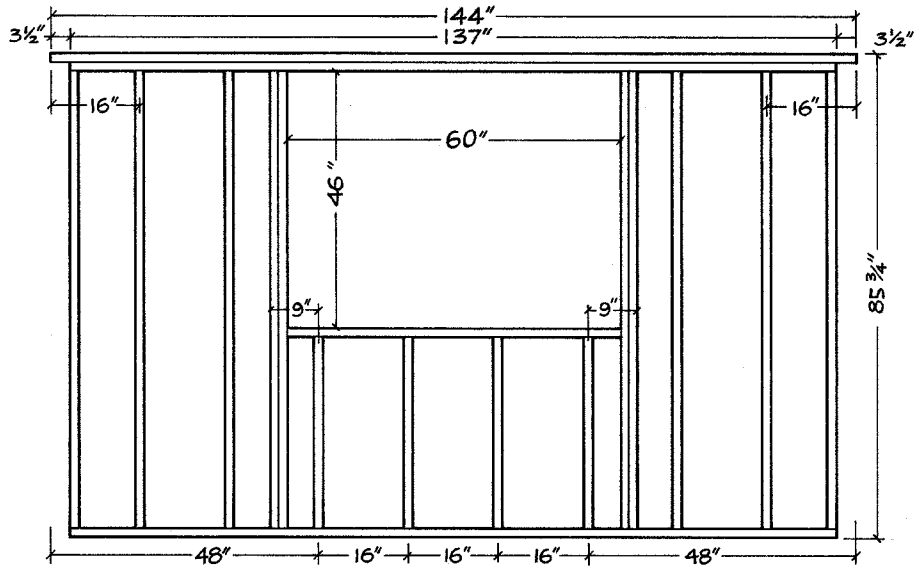

FIGURE 3
Wall Framing, Front

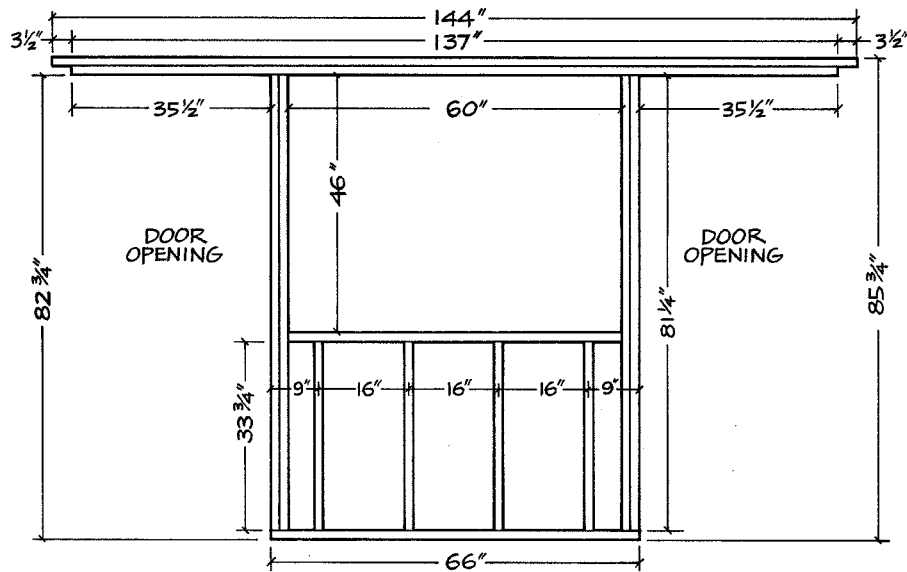

FIGURE 4
Wall Framing, Ends

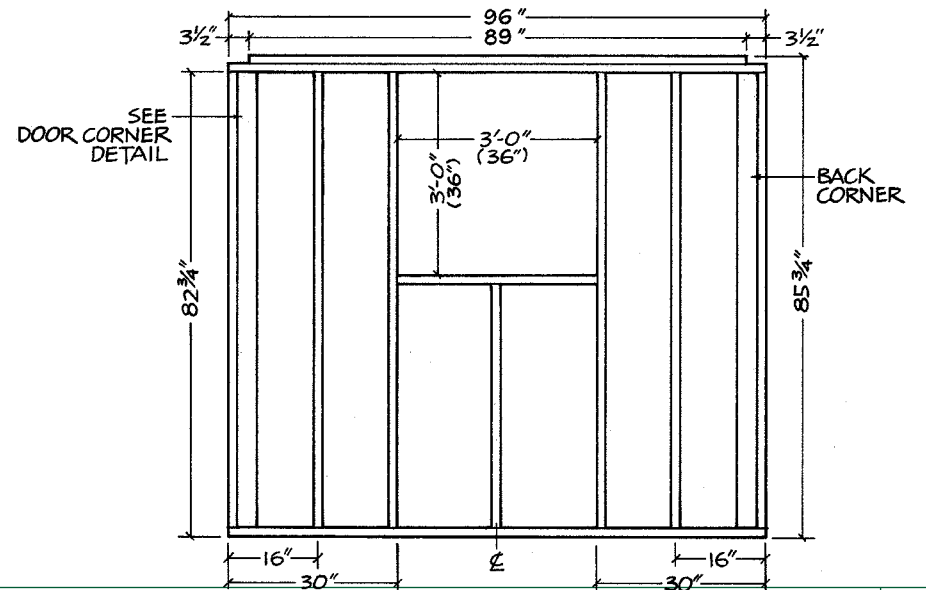

FIGURE 5
Door Corner Detail

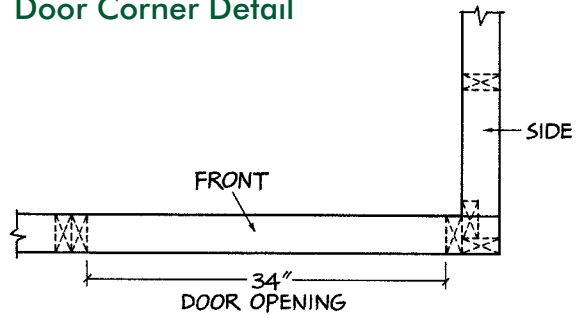

FIGURE 6
Back Corner Detail

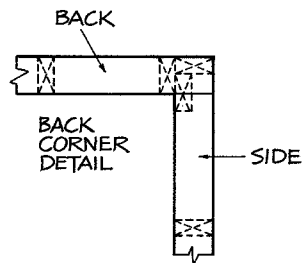

FIGURE 7
Wall, Erected

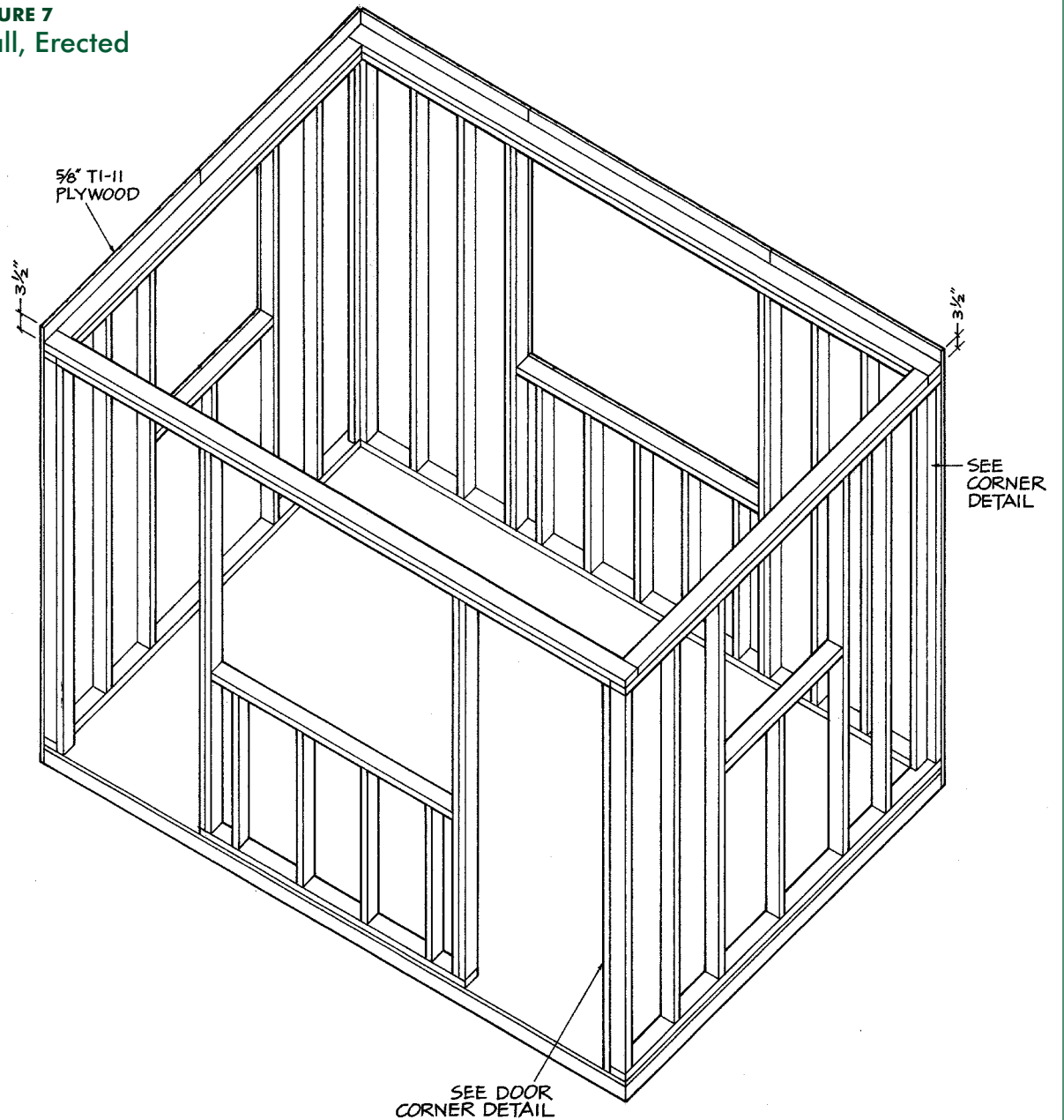

FIGURE 8
Main Roof Framing

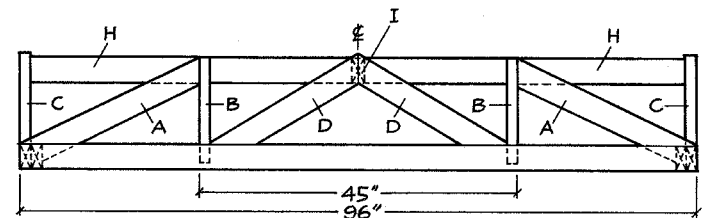
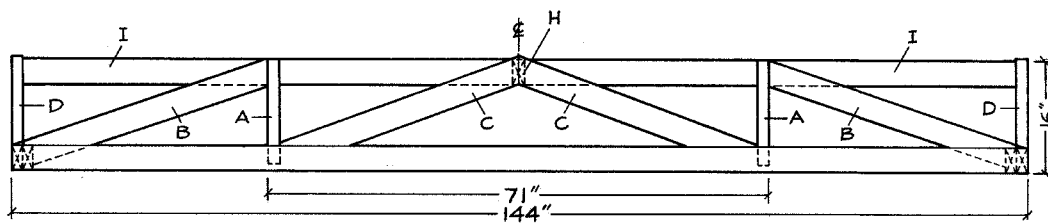
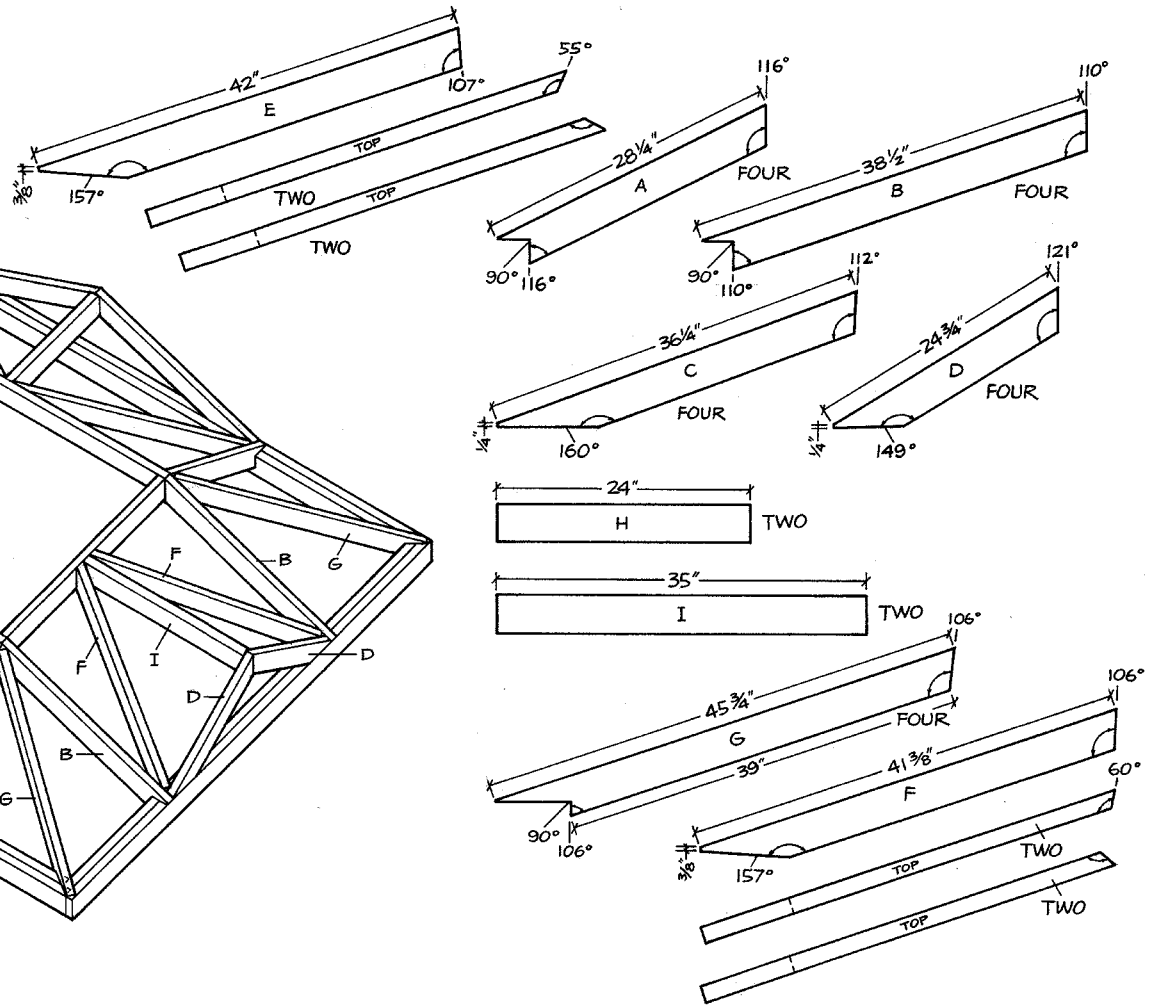
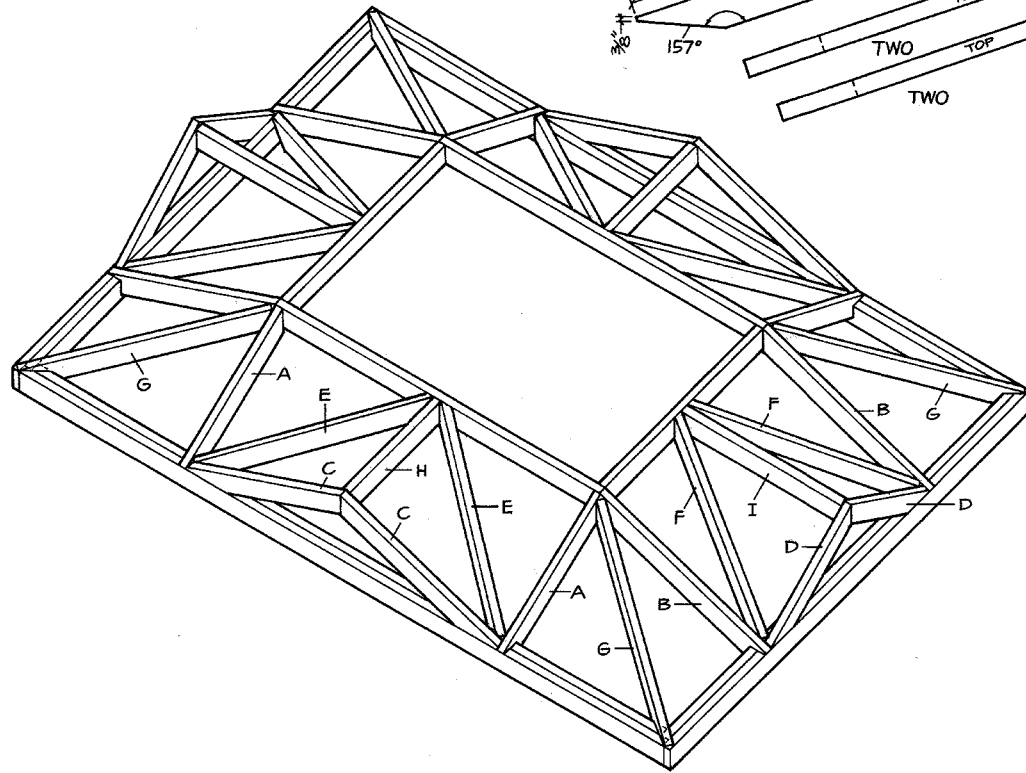

FIGURE 9
Cupola Framing

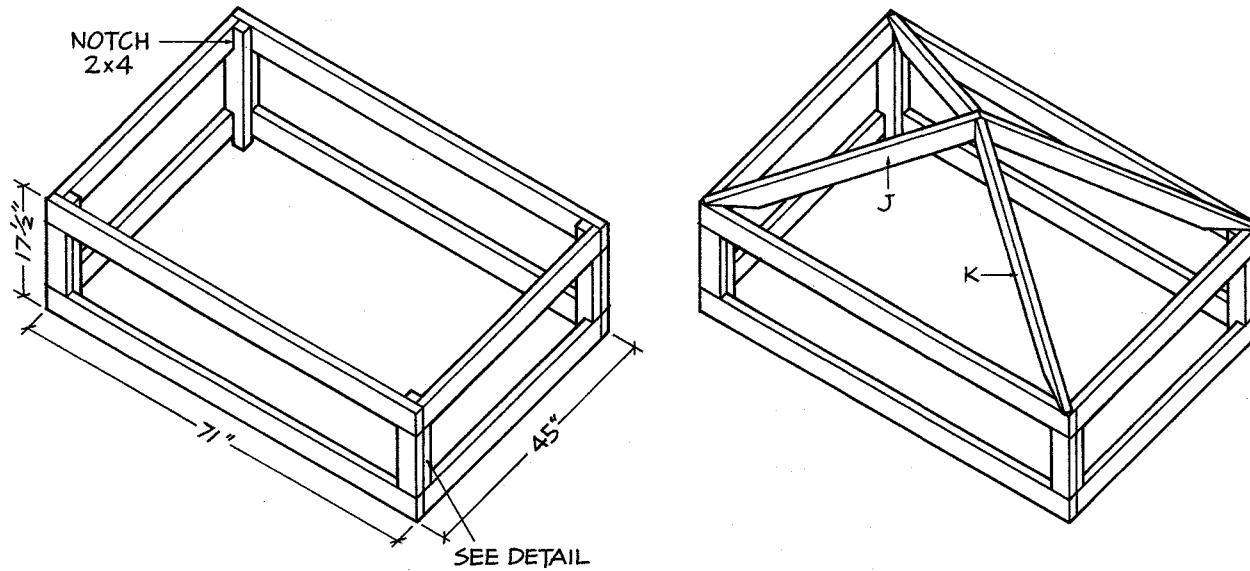

FIGURE 10
Cupola Corner Detail, Top View

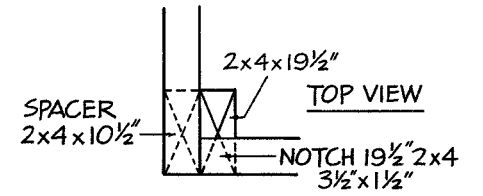

FIGURE 11
Cupola Corner Detail, Side View

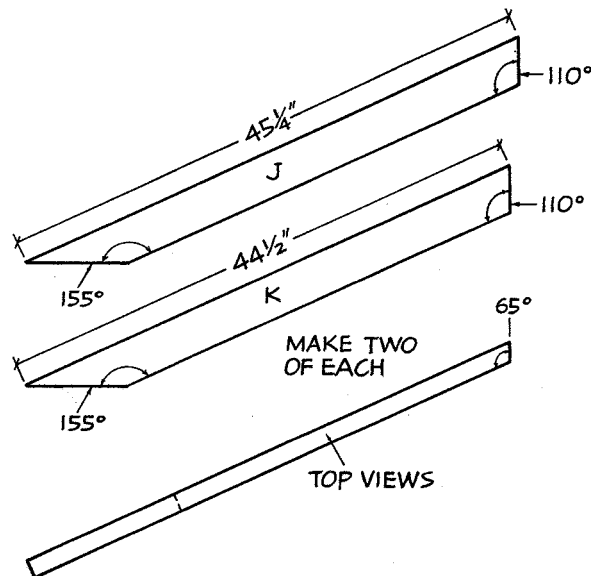
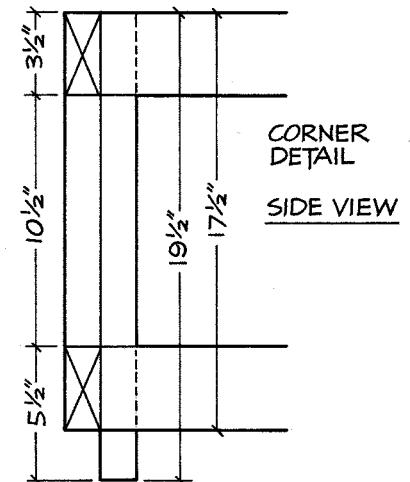

FIGURE 12
1/2" Roof Panels, Outside

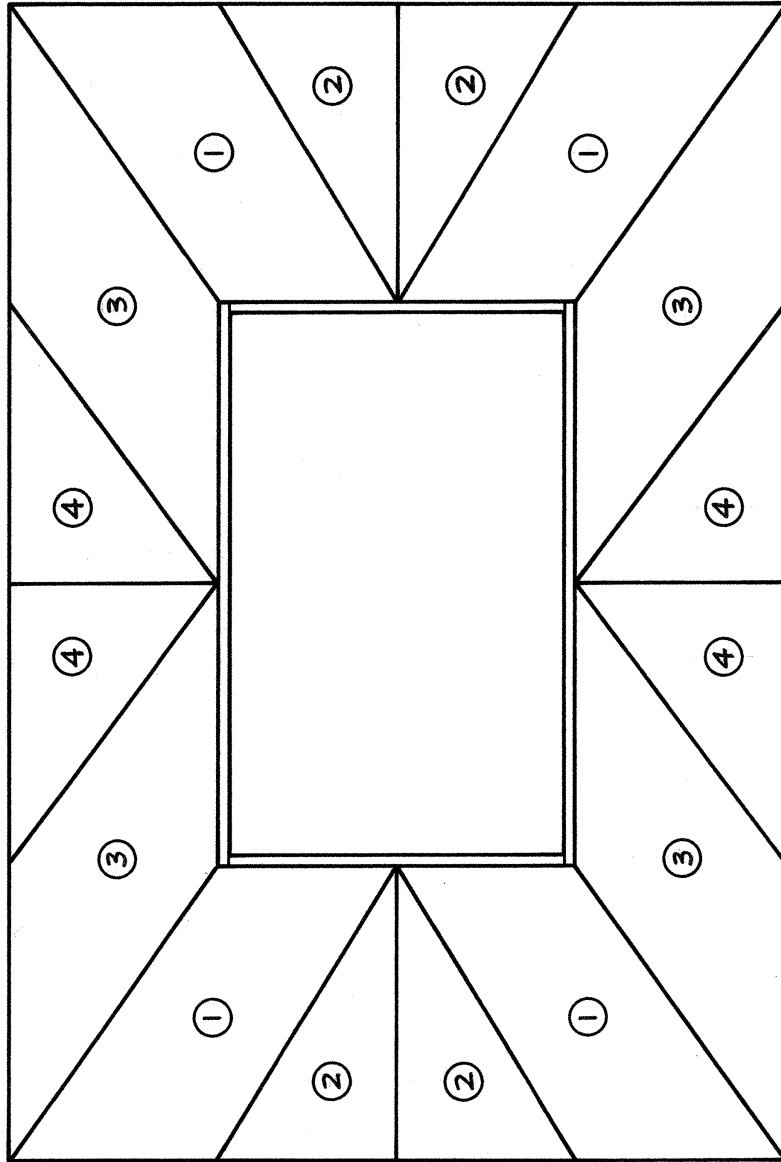

FIGURE 13
Corner Trim Detail, Outside

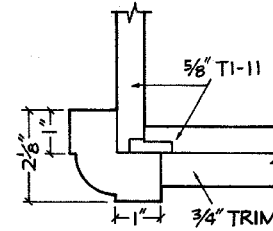

FIGURE 14
Window Trim Detail, End

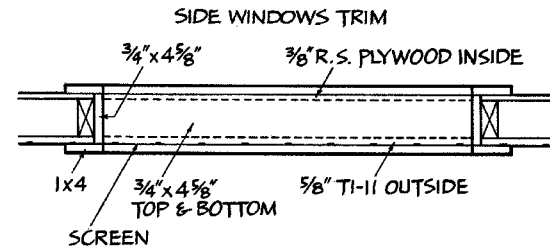

FIGURE 15
3/8" Roof Panels, Inside

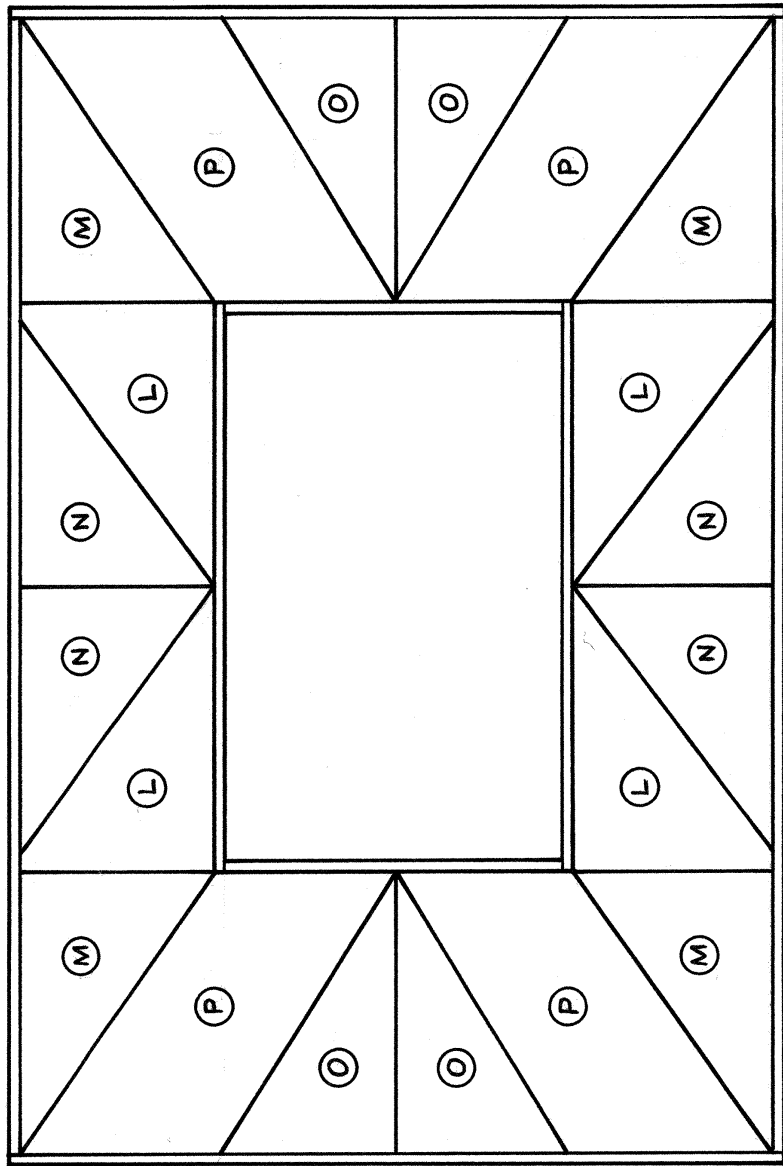

FIGURE 16
Constructed Kitchen, Front View

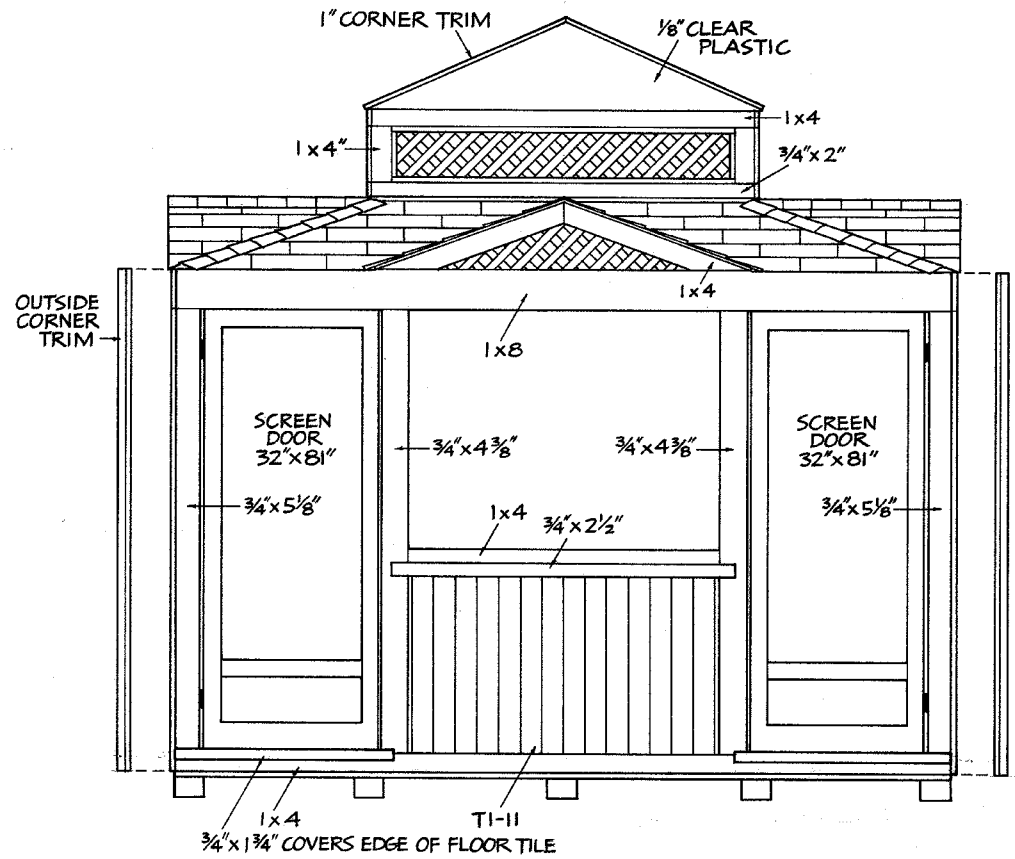

FIGURE 17
Kitchen, End View

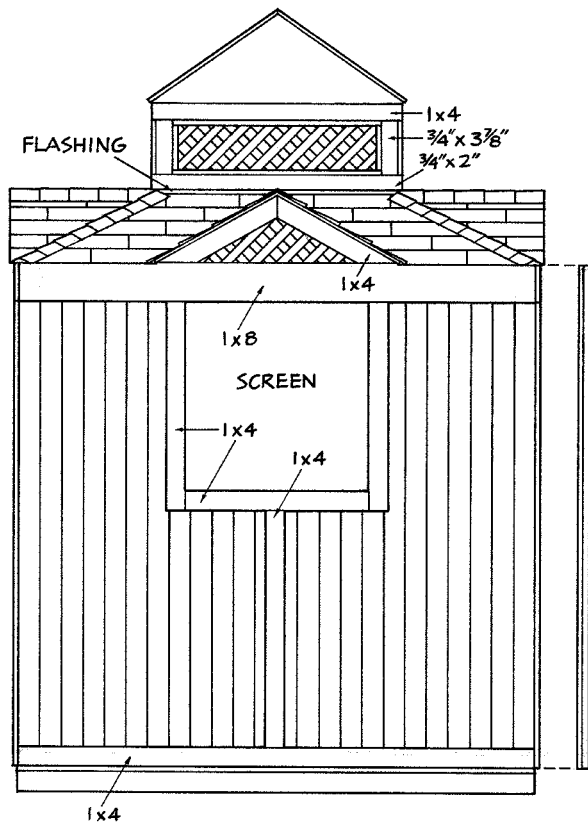

FIGURE 18
Kitchen, Back View

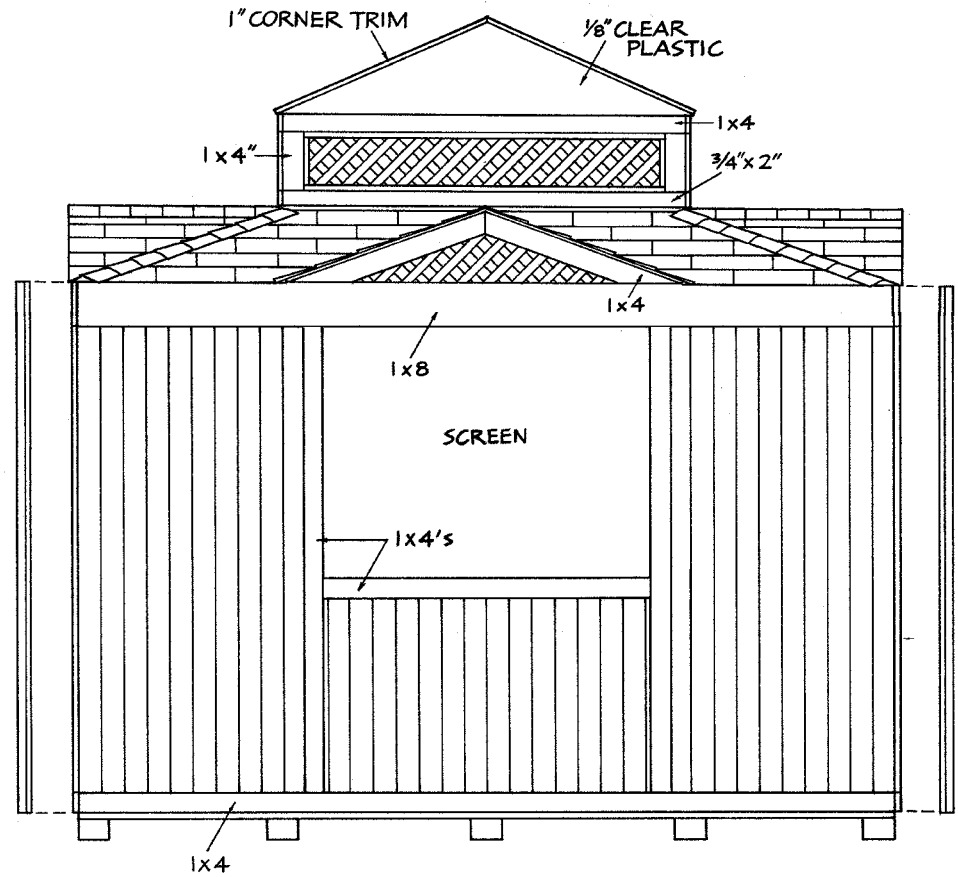

FIGURE 19
Cupola with Screen, Lattice and Trim

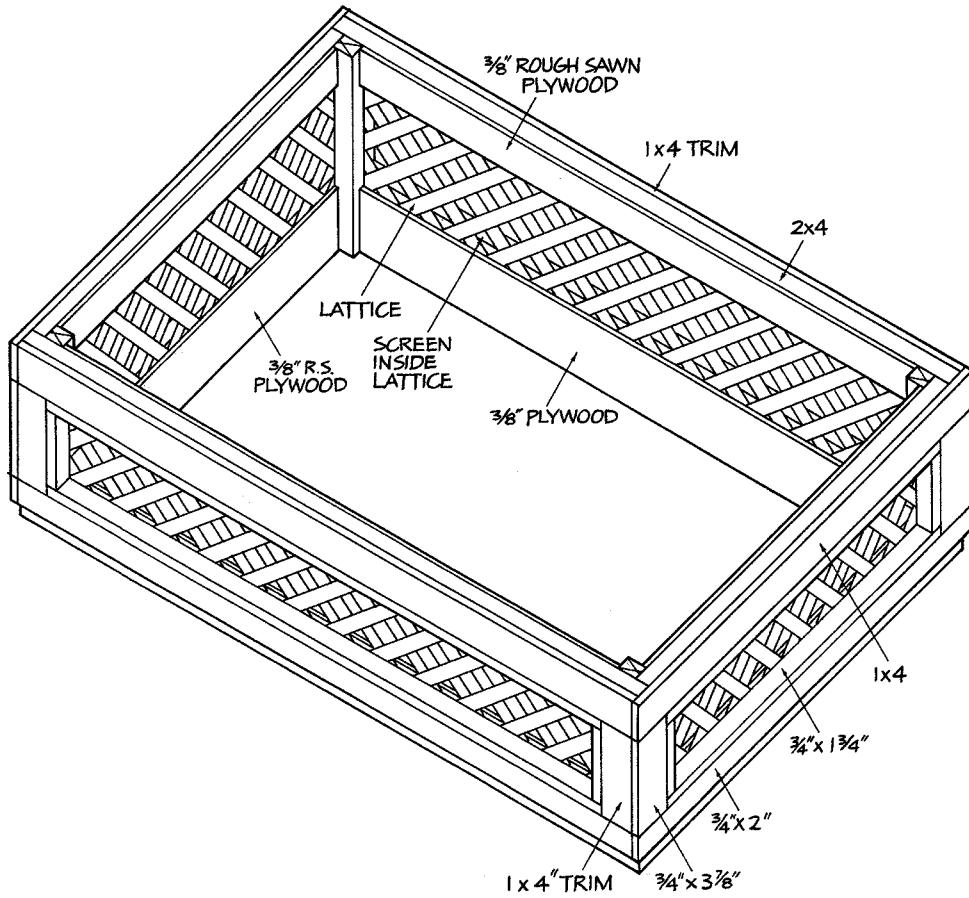

FIGURE 20
Lattice Detail

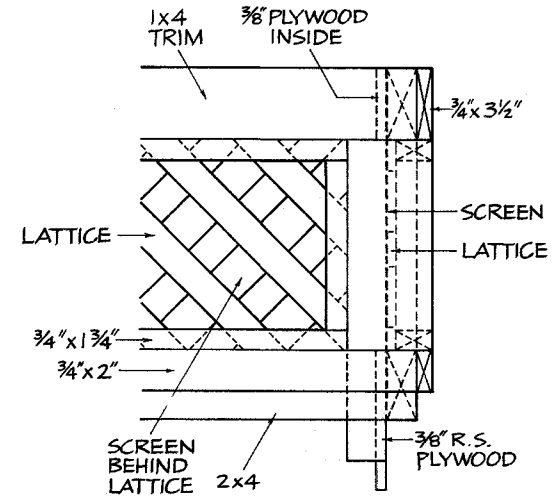

FIGURE 21
Clear Sheet Plastic, Cupola Skylight

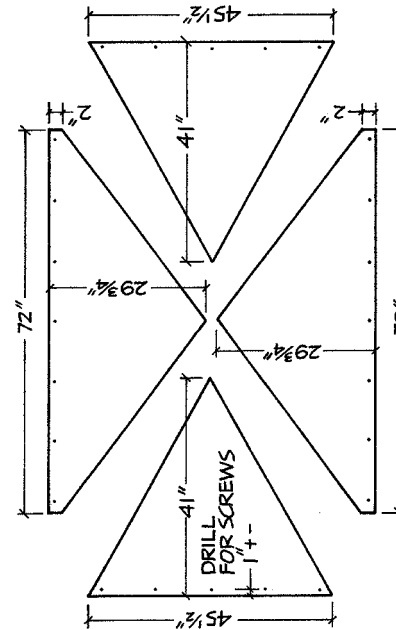

FIGURE 22
Plywood Jig for Deck

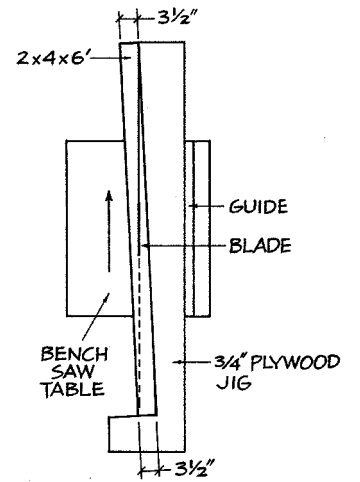

FIGURE 23
Deck Framing

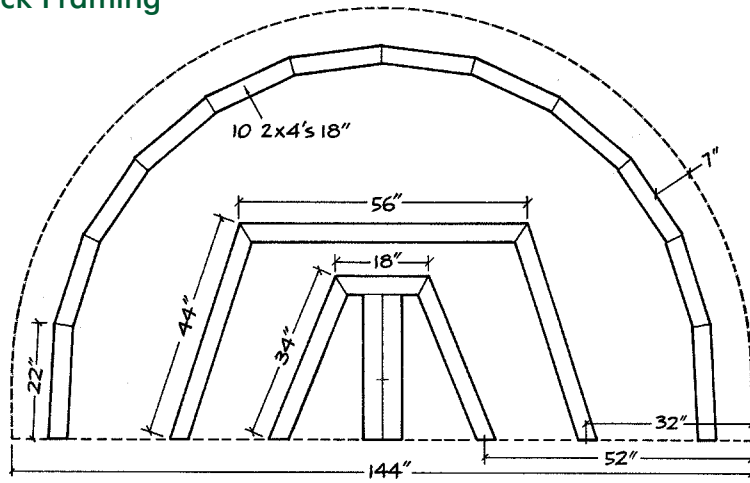

FIGURE 24
Decking

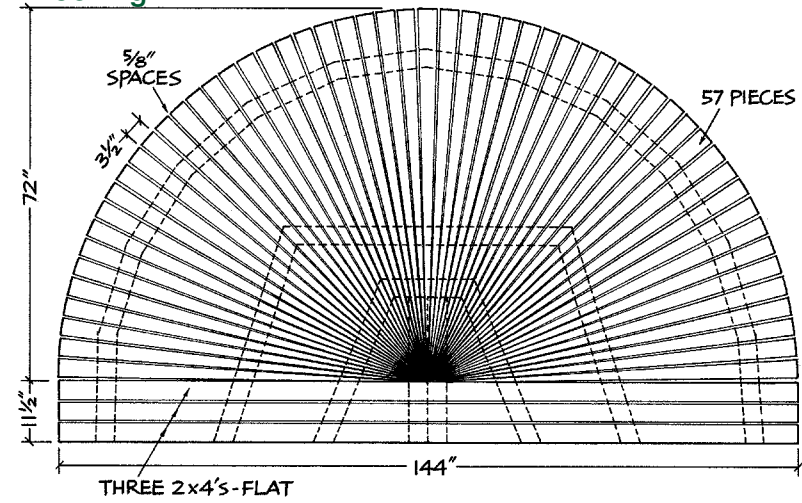

FIGURE 25
Bar Framing

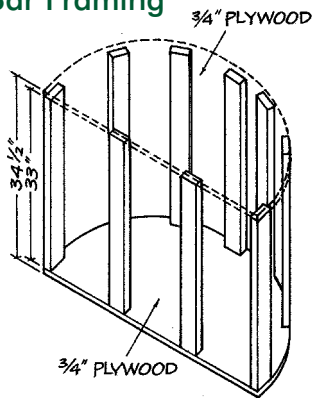

FIGURE 27
Bar Siding

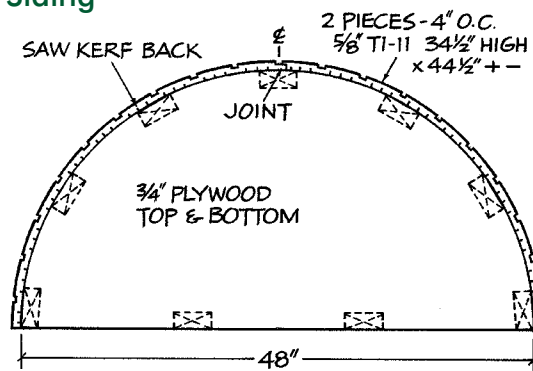

FIGURE 26
Bar Framing, Top View

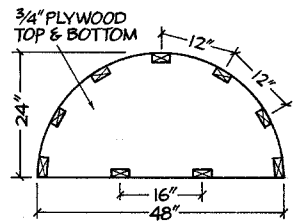

FIGURE 28
Bar Top

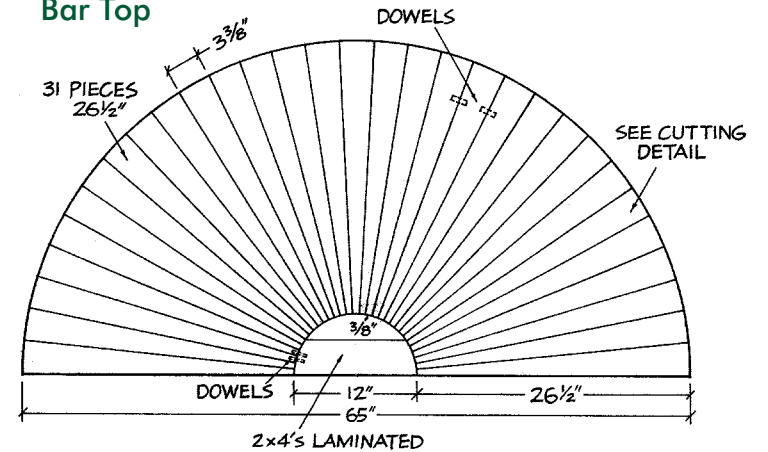

FIGURE 29
Bar Top Detail

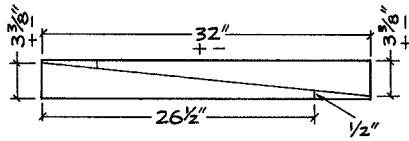

FIGURE 30
Bar Siding, Saw Kerf

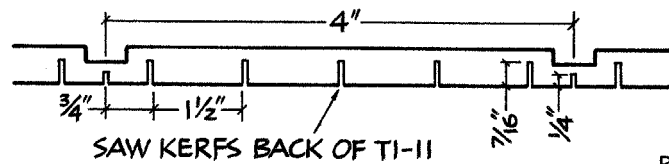

FIGURE 31
Bar Tile Base

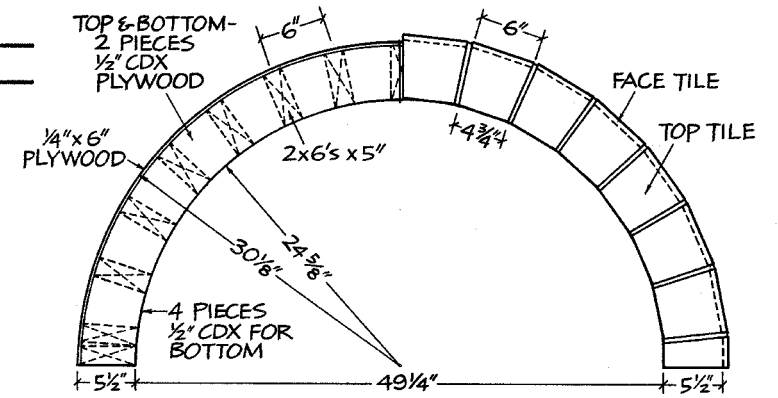

FIGURE 32
Bar Tile Base / Shim Detail

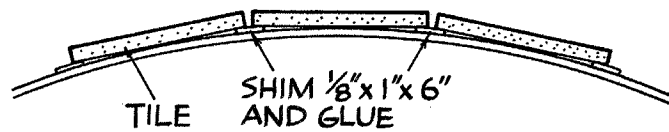

FIGURE 34
Back Cabinet / Counter with Sink

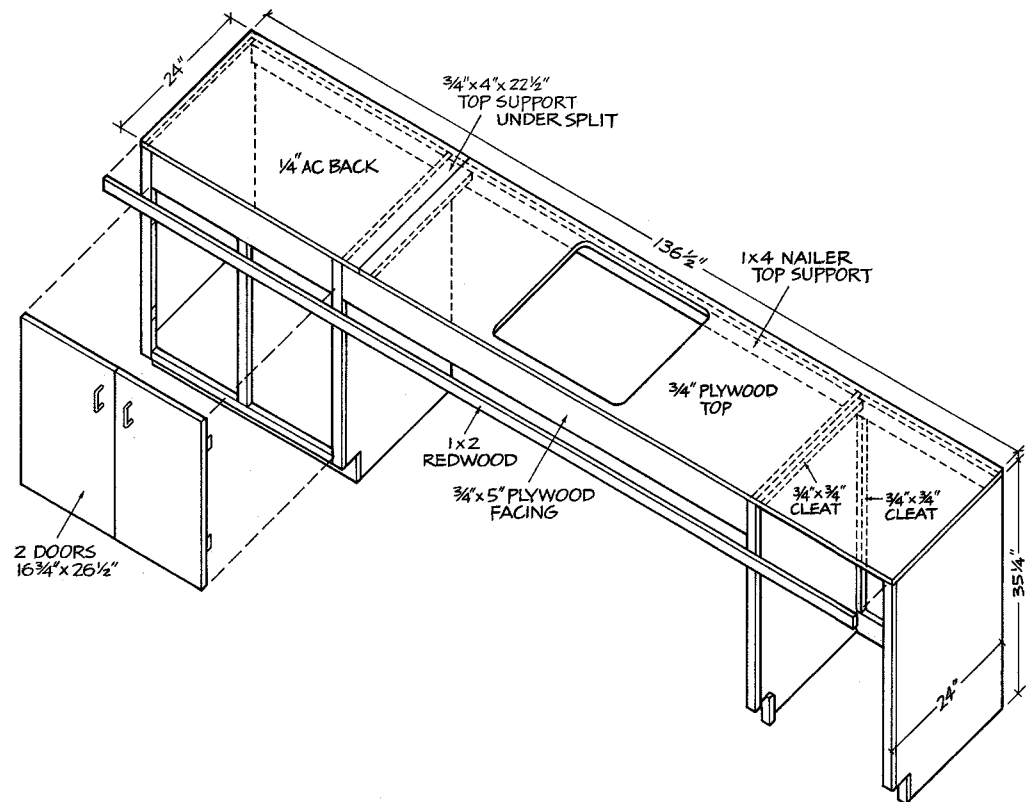

FIGURE 33
Bar Tile Base Detail

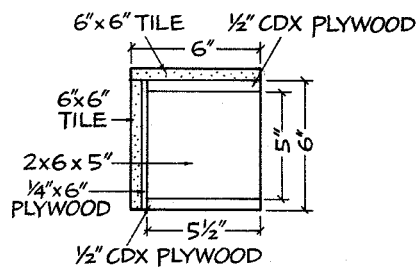

FIGURE 35
Back Cabinet / Counter, Front View

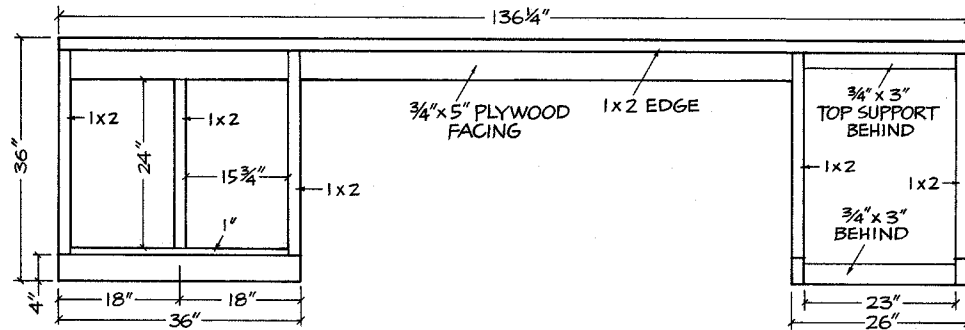

FIGURE 36
Front Cabinet with Grill

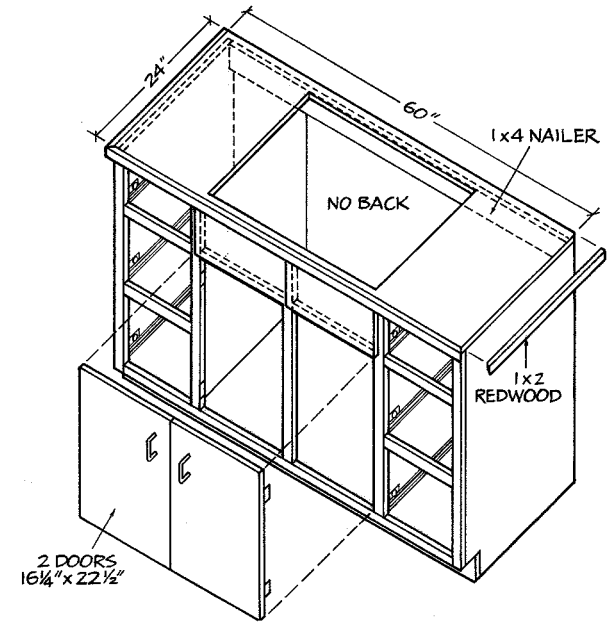

FIGURE 37
Front Cabinet, Front View

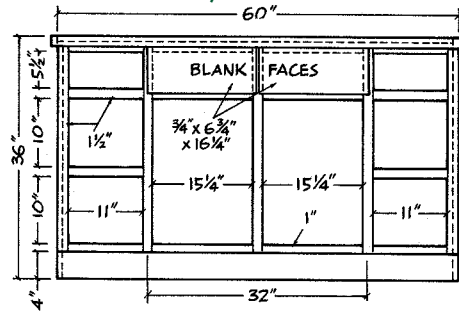

FIGURE 38
Drawers

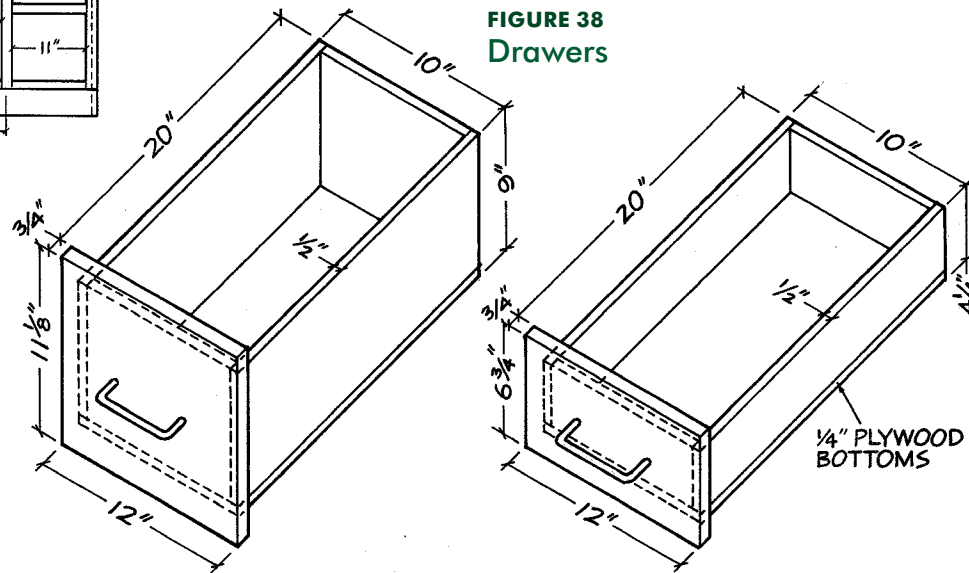

FIGURE 39
Adjustable Shelf

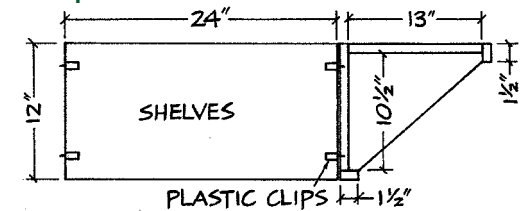

FIGURE 40
Corner Shelves

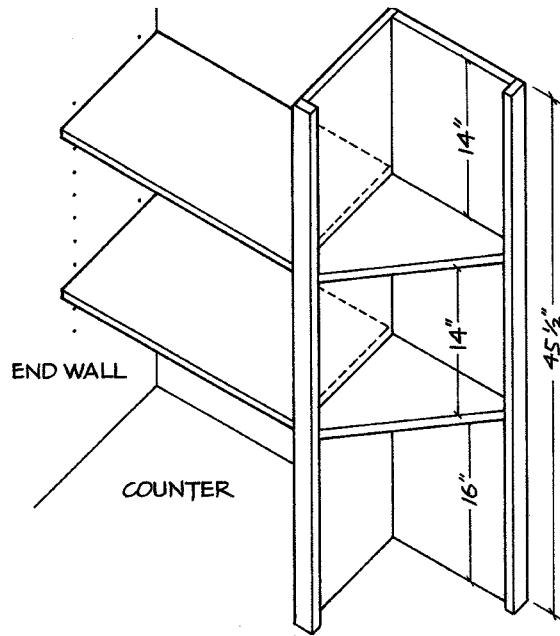
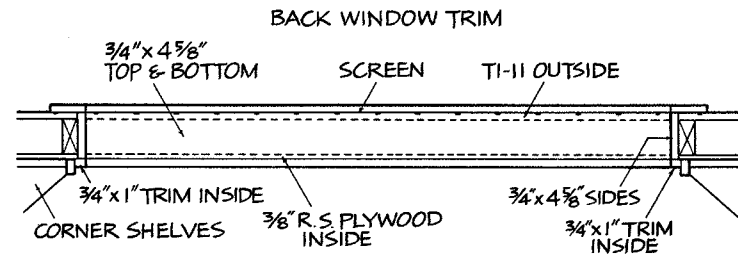

FIGURE 41
Back Window Trim Detail



BUILDING HINTS

These general hints will help you achieve the best possible results in working with APA wood structural panel products. They apply not only to this plan but to all projects you may undertake using APA trademarked panels. Since building methods and interpretation of suggestions may vary, APA – The Engineered Wood Association cannot accept responsibility for results of an individual's project efforts.

PLANNING. Before starting, study the plan carefully to make sure you understand all details.

LAYOUT. Following the panel layout, draw all parts on the panel using a straightedge and carpenter's square for accuracy. Use a compass to draw corner radii. Be sure to check the width of your saw cut and allow for saw kerfs when plotting dimensions.

CUTTING. When hand-sawing, support panel firmly with tile best side facing up. Use a 10 to 15 point cross-cut saw. Use a fine-toothed coping saw for curves. For inside cuts, start hole with a drill and use a coping or keyhole saw. When power sawing on a radial or table saw, the best side of the panel should be face up. A plywood blade works best but a sharp combination blade may be used. When using a portable power saw, the best side of the panel should be down. For curved cuts, use a jigsaw, bandsaw or saber saw. Be sure the blade enters the face of the panel. Use the finest tooth possible for a smooth and even cut. For prolonged cutting of nonveneer panels and those containing layers of reconstituted wood, a carbide-tipped blade is suggested.

Reduce panel to pieces small enough for easy handling with first cuts. Plan to cut matching parts with the same saw setting. Scrap lumber clamped or tacked securely in place beneath the panel prevents splintering on the back side.

Overlaid panels can be worked in the same manner as regular grades with these exceptions: sawing and drilling should always be done with the cutting edge of the tool entering the panel face. To minimize chipping at the point of tool exit, use a piece of scrap wood as a backup or place tape along the line of the cut.

DRILLING. Support panel firmly. Use brace and bit for larger holes. When point appears through panel, reverse and complete hole from back. Finish slowly to avoid splintering.

PLANING. Remember, edge grain of the panel runs in alternate directions so plane from ends toward center. Use shallow set blade.

SANDING. Many APA panels are sanded smooth in manufacture – one of the big time-savers in their use – so only minimum surface sanding is necessary. You may find it easier to sand cut edges smooth before assembling each unit. Use medium or finer sandpaper before sealer or flat undercoat is applied. Use fine sandpaper after sealing and in direction of grain only.

ASSEMBLY. Construction by section makes final assembly easier. Drawers, cabinet shells and compartments, for example, should be handled as individual units. For strongest possible joints, use glue with screws or nails. Check for a good fit by holding pieces together. Contact should be made at all points for lasting strength. Mark nail location along edge of piece to be nailed. In careful work where nails must be very close to an edge, predrill using a drill bit slightly smaller than nail size. Always predrill for screws.

Apply glue to clean surfaces according to manufacturer's instructions. Press surfaces firmly together until bead appears. Check for square, then nail and apply clamps if possible to maintain pressure until glue sets. For exterior exposure, use resorcinol-type (waterproof) glue; for interior work, use liquid resin (white) or urea resin-type glues. Other glues are available for special gluing needs.

FINISHING FOR INTERIOR USE.

Little, if any, surface preparation is usually required. Sanded panels require only light sanding to remove blemishes or to smooth fillers which might be used to patch any dents or openings in the surface. Sand in the direction of the grain only with fine sandpaper. If an opaque finish is to be used, cover any knots, pitch streaks, or sap spots with shellac or a stain-resistant sealer. Do not apply finishes over dust, glue or spots of oil.

Three types of finishing systems may be used for interior applications: paints, stains and natural finishes.

When using paint systems, a solvent-thinned (oil-based) primer should be used to minimize grain raise and prevent staining. Gloss and semi-gloss enamel top coat provide a washable, durable surface. The top coat may be oil-based or alkyd-based (solvent-thinned) or latex (water-thinned), provided it is compatible with the primer.

Panels used for natural finishes should be carefully selected for pattern and appearance. For the most natural appearance, use two coats of a clear finish, such as a urethane, varnish or clear sealer. To pleasantly subdue any grain irregularities or repairs, a light stain finish may be applied either by color toning, which uses companion stain and non-penetrating sealer, or light staining, which uses a pigmented sealer, tinting material (stain, thin enamel or undercoat), and finish coat (varnish or lacquer). Finish Medium Density Overlaid (MDO) panels with a solid color acrylic latex stain or two-coat paint system (primer plus companion top coat).

FINISHING FOR EXTERIOR USE.

A top quality stain or paint will help maintain the panel's appearance and protect it from weathering. Since end grain absorbs and loses moisture rapidly, panels should be edge-sealed to help minimize possible damage. Use paint primer to seal panels to be painted, or use a paintable water-repellent preservative for panels which are to be stained.

For rough or textured panels, either high quality stain or acrylic house paint systems are recommended. Use a solvent-thinned semi-transparent stain for maximum grain show-through. Use only acrylic latex solid-color stain when it is desirable to hide the grain and color of the wood surface, but not its texture. Maximum protection of the wood is obtained by using a house paint system which consists of a stain-resistant primer and one or more acrylic latex top coats. Finish Medium Density Overlaid (MDO) panels with solid-color acrylic latex stain or a two-coat paint system (primer plus companion top coat).

Best performance is achieved by applying the first coat of finish by brushing. If the first coat of finish is sprayed on, it should be back-brushed or back-rolled to work it well into the wood surface. Additional coats may be sprayed without back-brushing.

Whatever finishing method is used – paint or stain – always use top quality materials and follow the manufacturer's instructions.