

8 x 10 Timber-frame Garden Shed

Includes: Step-By-Step Instructions, Complete Details & Materials Lists



Timber-framing is a traditional building method that uses a simple framework of heavy timber posts and beams connected with hand-carved joints. From the outside, a timber-frame building looks like a standard, stick-framed structure, but the stout, rough-sawn members give the interior the feel of an 18th-century barn or workshop.

This 8 × 10-ft. shed has the same rough-sawn timbers and basic design used in traditional timber-framing, but with joints that are easy to make. In addition to an attractive interior, the shed has a homemade skylight and a large side window that make it a bright, inviting space. If staying cool is a concern, install operable windows, or adapt the shed frame to add more windows. Adding roof vents can improve ventilation, as well.

The roof frame in this project is made with standard 2 × 4s, but if you're willing to pay a little more to improve the appearance, you can use rough-cut 2 × 4s or 4 × 4s for the roof framing.

Materials		
Description	Quantity/Size	Material
Foundation		
Drainage material	25 cu. ft.	Compactible gravel
Skids	3 @ 10'-0"	4 × 4 treated timbers
Floor Framing		
Rim joists	2 @ 10'-0"	2 × 6 pressure-treated
Joists	9 @ 8'-0"	2 × 6 pressure-treated
Joist clip angles	18	3 × 3 × 3" × 18-gauge galvanized
Floor sheathing	3 sheets 4 × 8'	3/4" tongue-&-groove ext.-grade plywood
Wall Framing		
Posts	6 @ 8'-0"	4 × 4 rough-sawn cedar
Window posts	2 @ 4'-0"	4 × 4 rough-sawn cedar
Girts	2 @ 10'-0", 2 @ 8'-0"	4 × 4 rough-sawn cedar
Beams	2 @ 10'-0", 2 @ 8'-0"	4 × 6 rough-sawn cedar
Braces	8 @ 2'-0"	4 × 4 rough-sawn cedar
Post bases	6, with nails	Simpson BC40
Post-beam connectors	8 pieces, with nails	Simpson LCE
L-connectors	4, with nails	Simpson A34
Roof Framing		
Rafters	12 @ 7'-0"	2 × 4
Collar ties	1 @ 10'-0"	2 × 4
Ridge board	1 @ 10'-0"	2 × 6
Metal anchors- rafters	8, with nails	Simpson H1
Gable-end blocking	4 @ 7'-0"	2 × 2
Exterior Finishes		
Siding	2 @ 14'-0", 8 @ 12'-0", 10 @ 10'-0", 29 @ 9'-0"	1 × 8 T&G V-joint rough-sawn cedar
Corner trim	8 @ 9'-0"	1 × 4 rough-sawn cedar
Fascia	4 @ 7'-0", 2 @ 12'-0"	1 × 6 rough-sawn cedar
Fascia trim	4 @ 7'-0", 2 @ 12'-0"	1 × 2 rough-sawn cedar

Subfascia	2 @ 12'-0"	1 × 4 pine
Plywood soffits	1 sheet 4 × 8'	3/4" cedar or fir plywood
Soffit vents	4 @ 4 × 12"	Louver with bug screen
Flashing (door)	4 linear ft.	Galvanized—18 gauge
Roofing		
Roof sheathing	6 sheets 4 × 8'	1/2" ext.-grade plywood
Asphalt shingles	1.7 squares	250# per square (min.)
15# building paper	140 sq. ft.	
Metal drip edge	2 @ 12'-0", 4 @ 7'-0"	Galvanized metal
Roof vents (optional)	2 units	
Roofing cement	1 tube	
Skylight		
Frame	1 @ 12'-0"	2 × 8
Glazing tape	24 linear ft.	
Stops	1 @ 12'-0"	1 × 2 clear redwood
Glass	1 piece—field measure	5/16" tempered, clear (Optional: 1/4" plexiglass, clear)
Flashing	14 linear ft.	Prefinished metal-24 gauge
Window		
Frame	4 @ 6'-0"	3/4 × 4 1/4" (actual) S4S cedar
Mullion	1 @ 4'-0"	2 × 4 S4S cedar
Stops	8 @ 6'-0"	1 × 2 S4S cedar
Glazing tape	44 linear ft.	Glazing tape
Glass	2 pieces—field measure	1/4" tempered, clear
Trim	4 @ 6'-0", 4 @ 4'-0"	1 × 3 rough-sawn cedar
Door		
Frame	2 @ 7'-0", 1 @ 4'-0"	3/4 × 4 1/4" (actual) S4S cedar
Stops	2 @ 7'-0", 1 @ 4'-0"	1 × 2 S4S cedar
Panel material	7 @ 7'-0"	1 × 6 T&G V-joint rough-sawn cedar
Z-brace	2 @ 6'-0", 1 @ 8'-0"	1 × 6 rough-sawn cedar
Strap hinges	3	
Trim	5 @ 7'-0"	1 × 3 rough-sawn cedar

Fasteners		
60d common nails	16 nails	
20d common nails	32 nails	
16d galvanized common nails	3 1/2 lbs.	
10d common nails	1 lb.	
10d galvanized casing nails	1/2 lb.	
8d galvanized box nails	1 1/2 lbs.	
8d galvanized finish nails	7 lbs.	
8d box nails	1/4 lb.	
6d galvanized finish nails	40 nails	
3d galvanized finish nails	50 nails	
1 1/2" joist hanger nails	72 nails	
2 1/2" deck screws	25 screws	
1 1/2" wood screws	50 screws	
7/8" galvanized roofing nails	2 lbs.	
3/8" × 6"lag screws	16 screws	
Silicone- latex caulk	2 tubes	
Construction adhesive	4 tubes	

FRONT FRAMING ELEVATION

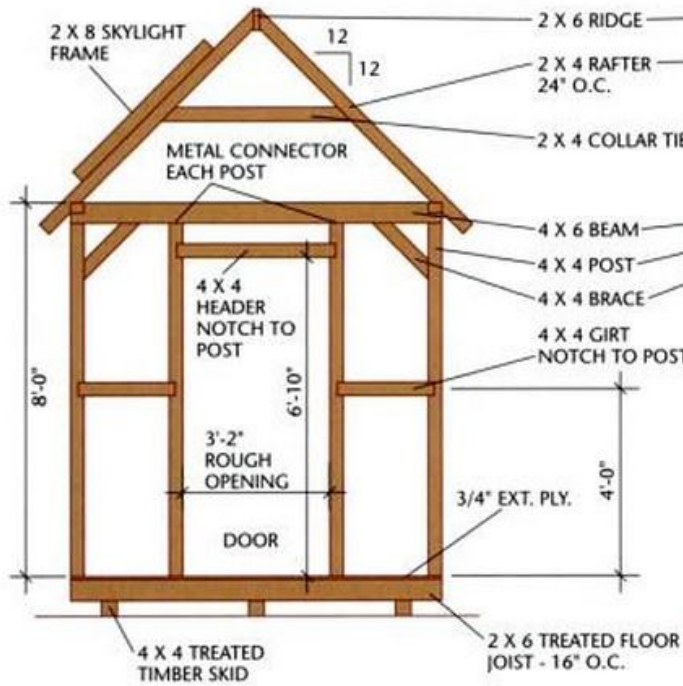

LEFT SIDE FRAMING ELEVATION

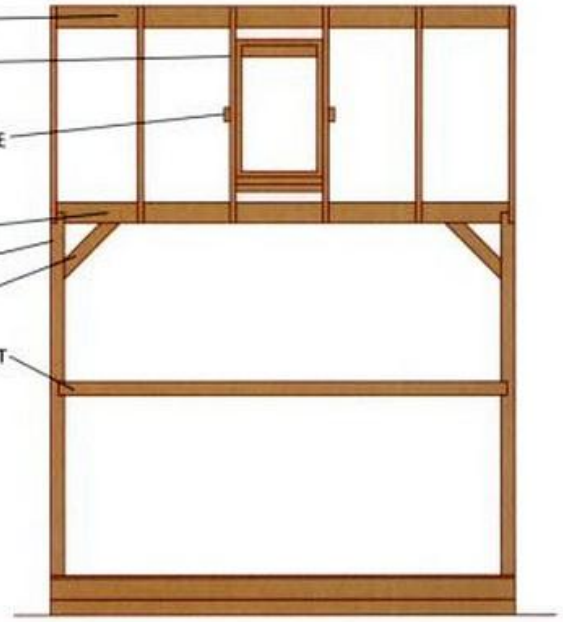

REAR FRAMING ELEVATION

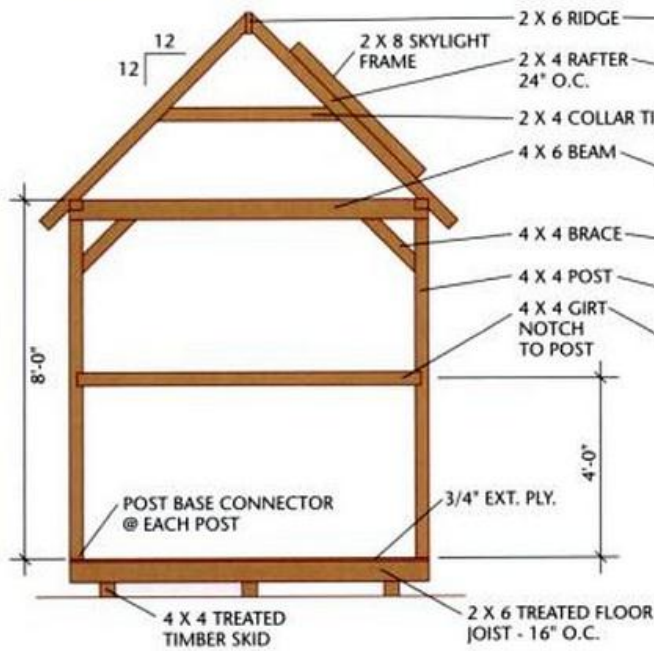

RIGHT SIDE FRAMING ELEVATION

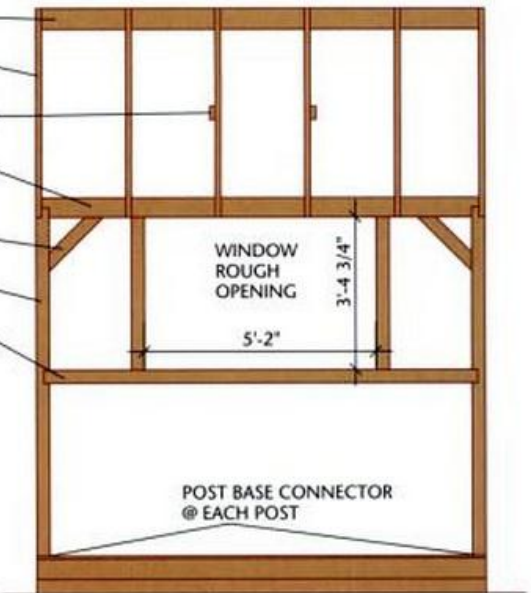

BUILDING SECTION

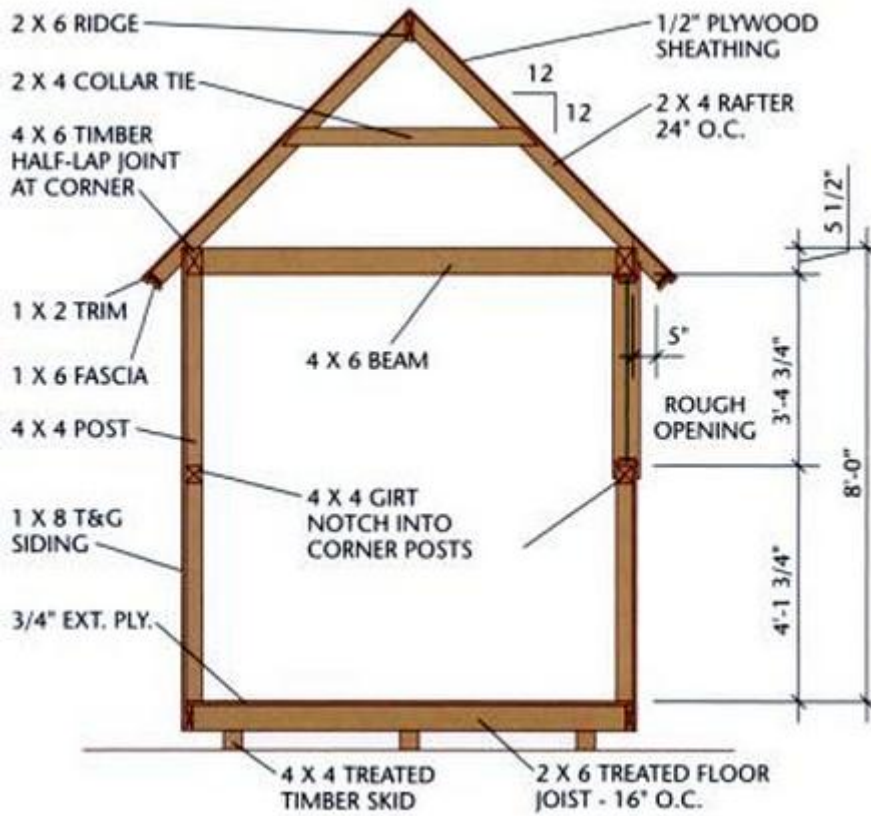

RAFTER TEMPLATE

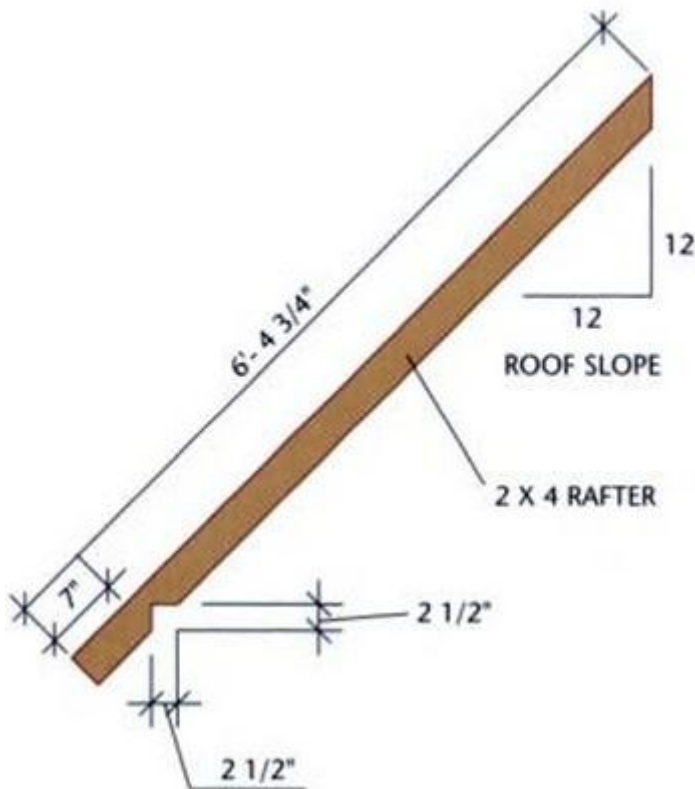

FLOOR FRAMING PLAN

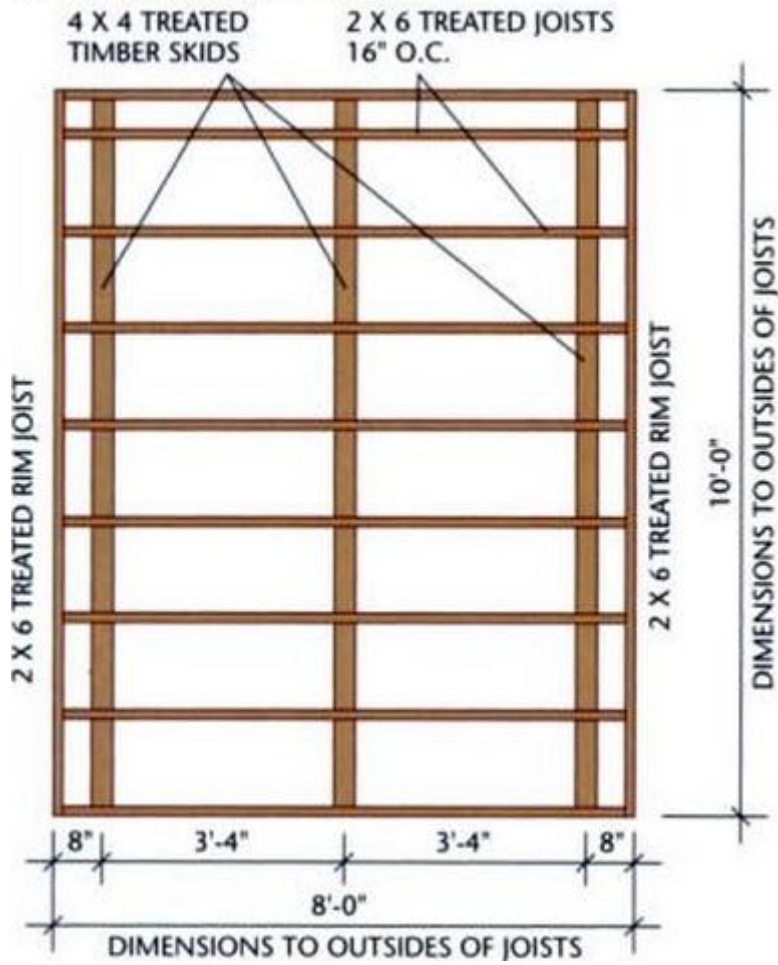

FLOOR PLAN

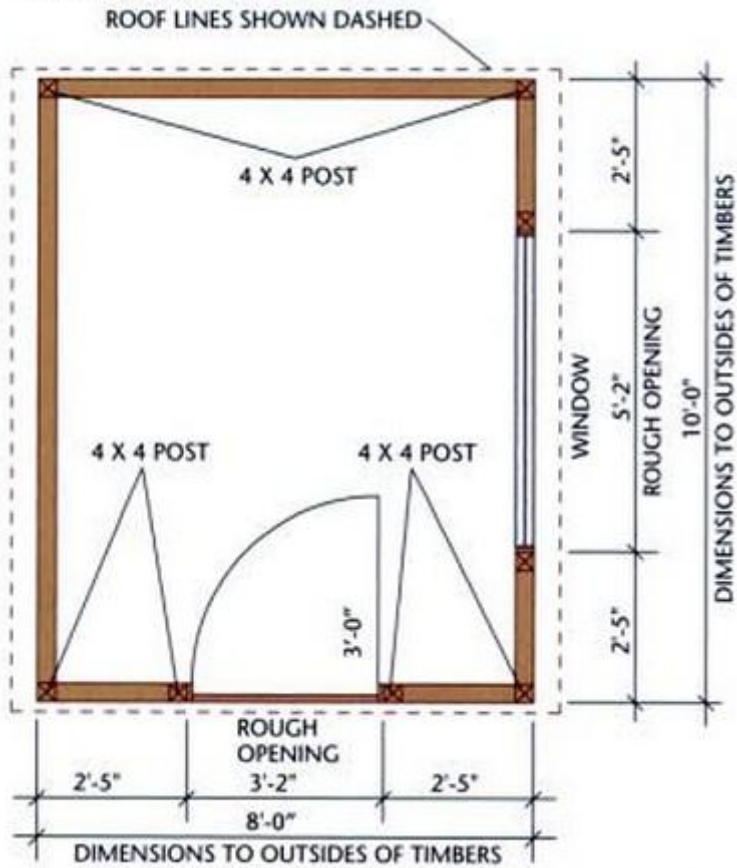

FRONT ELEVATION

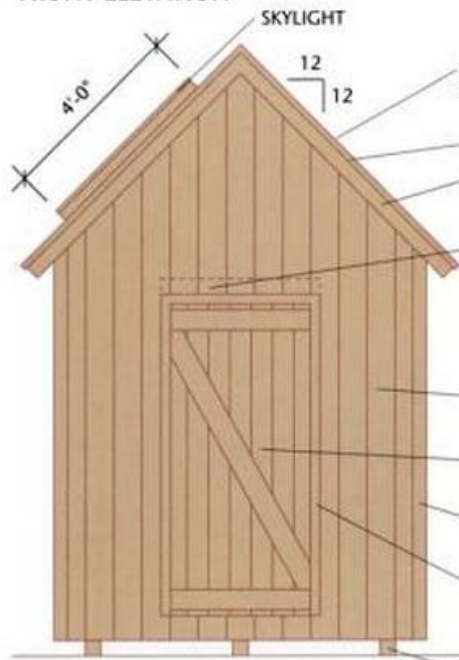

LEFT SIDE ELEVATION

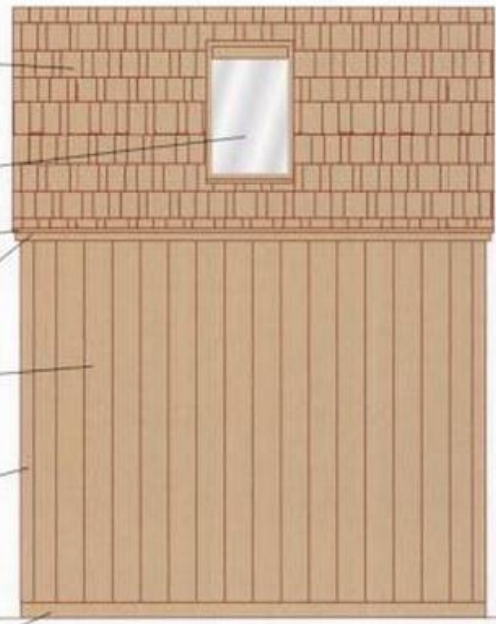

- ASPHALT SHINGLES
- 1 X 2 TRIM
- 1 X 6 FASCIA
- SKYLIGHT
- FLASHING
- 1 X 2 TRIM
- 1 X 6 FASCIA
- 1 X 8 T&G SIDING
- HOMEMADE DOOR
- 1 X 4 TRIM
- 1 X 3 TRIM
- 4 X 4 TREATED TIMBER SKID

REAR ELEVATION



RIGHT SIDE ELEVATION

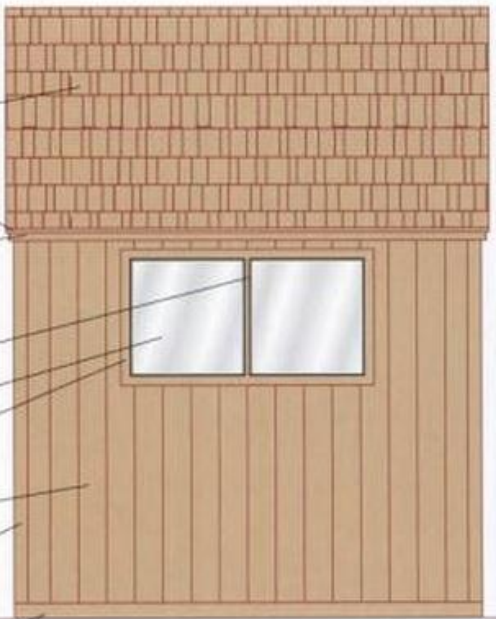

- SKYLIGHT
- ASPHALT SHINGLES
- 1 X 2 TRIM
- 1 X 6 FASCIA
- 2 X 4 MULLION
- HOMEMADE WINDOW
- 1 X 3 TRIM
- 1 X 8 T&G SIDING
- 1 X 4 TRIM
- 4 X 4 TREATED TIMBER SKID

GABLE OVERHANG DETAIL

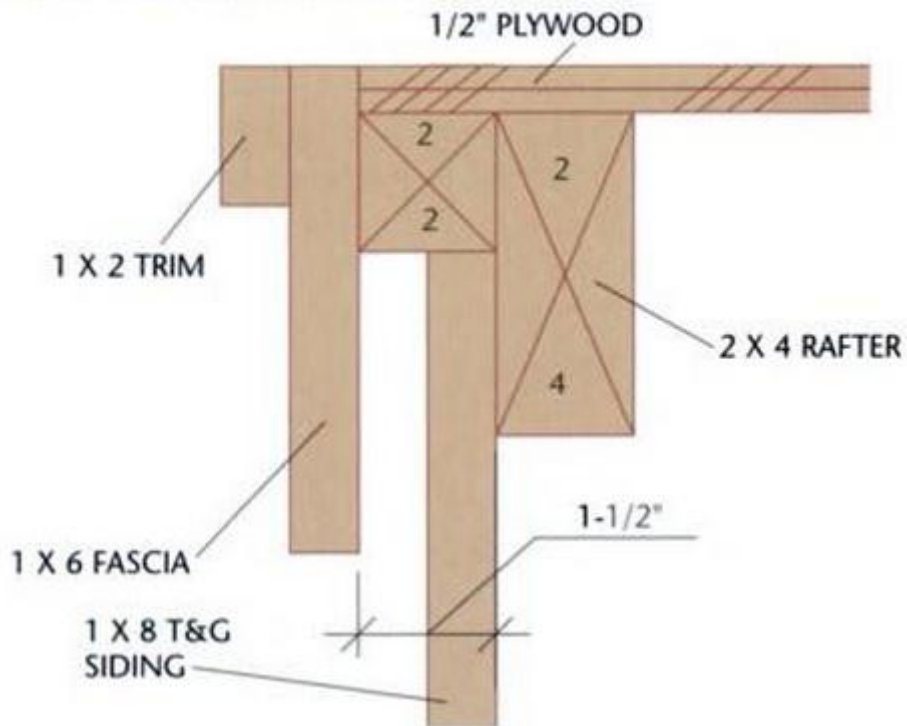

EAVE DETAIL

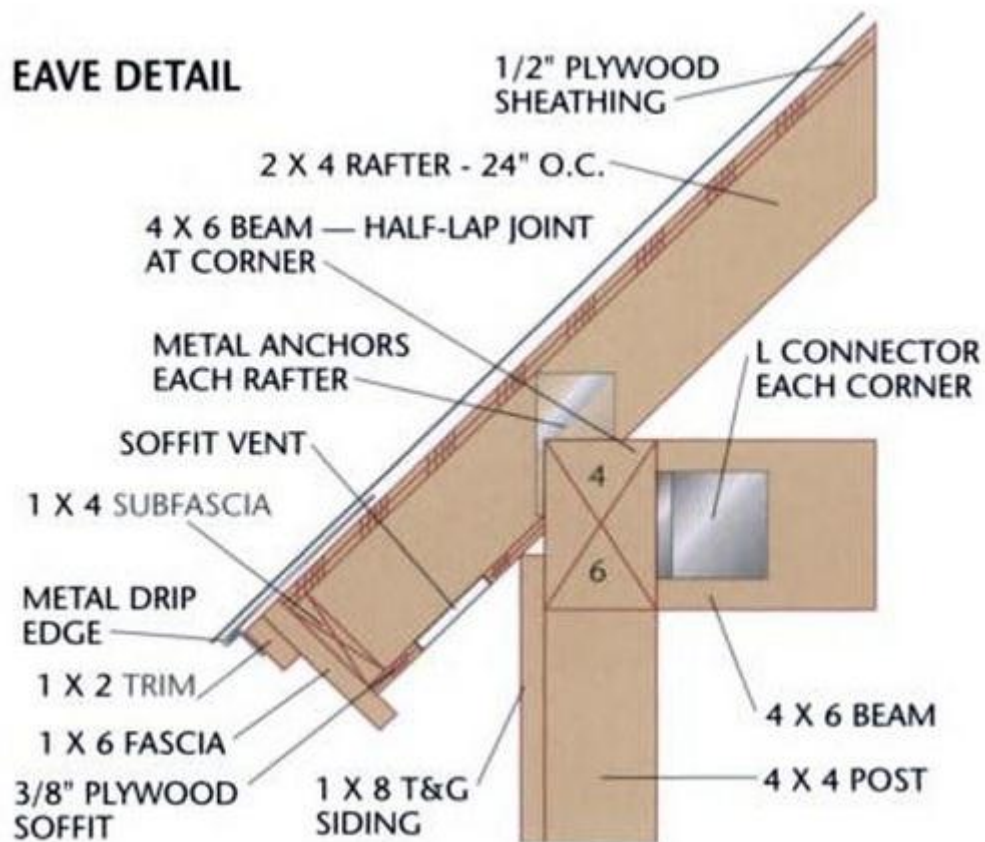

DOOR JAMB DETAIL

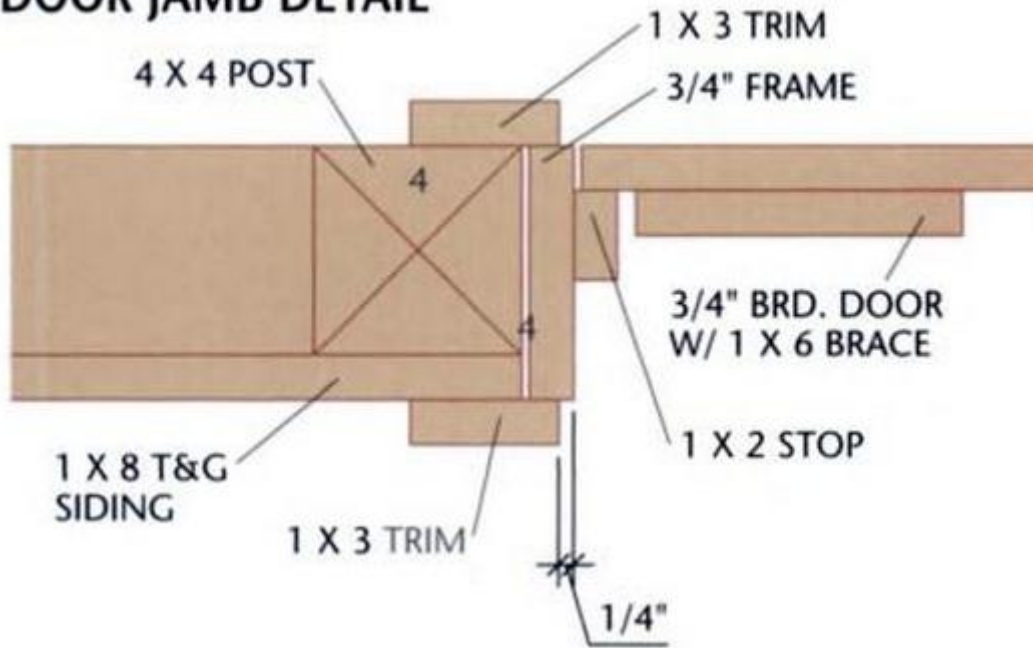

WINDOW JAMB DETAIL

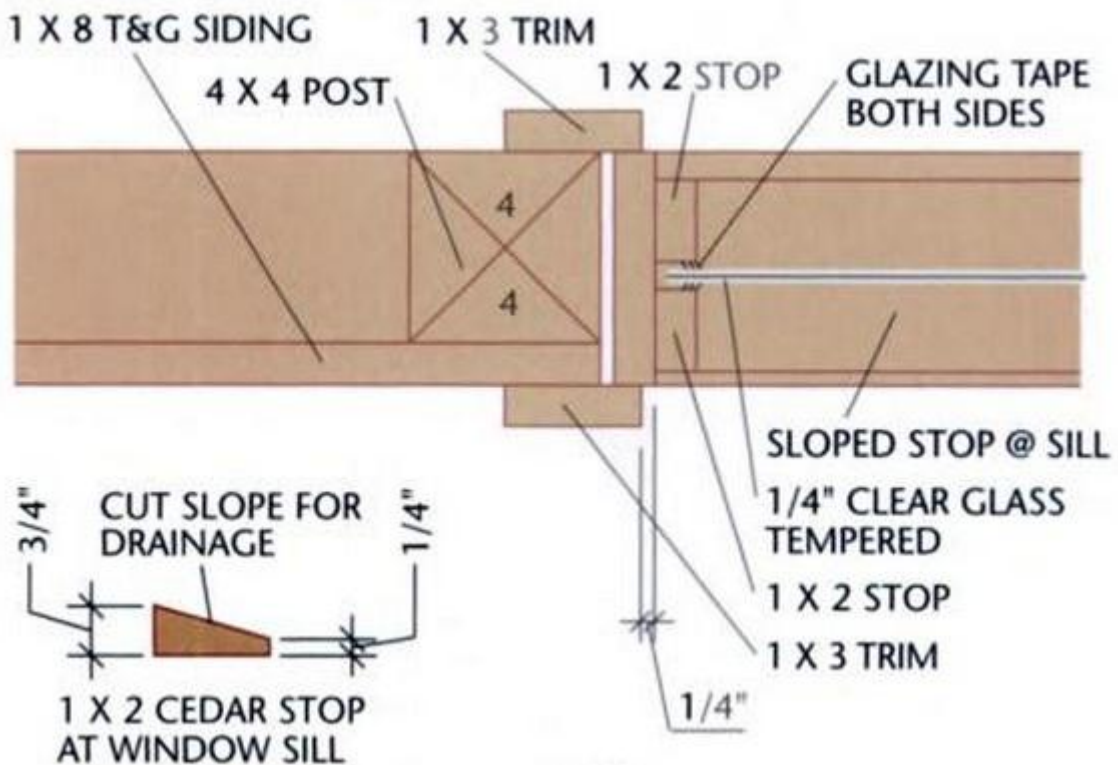

SKYLIGHT DETAIL

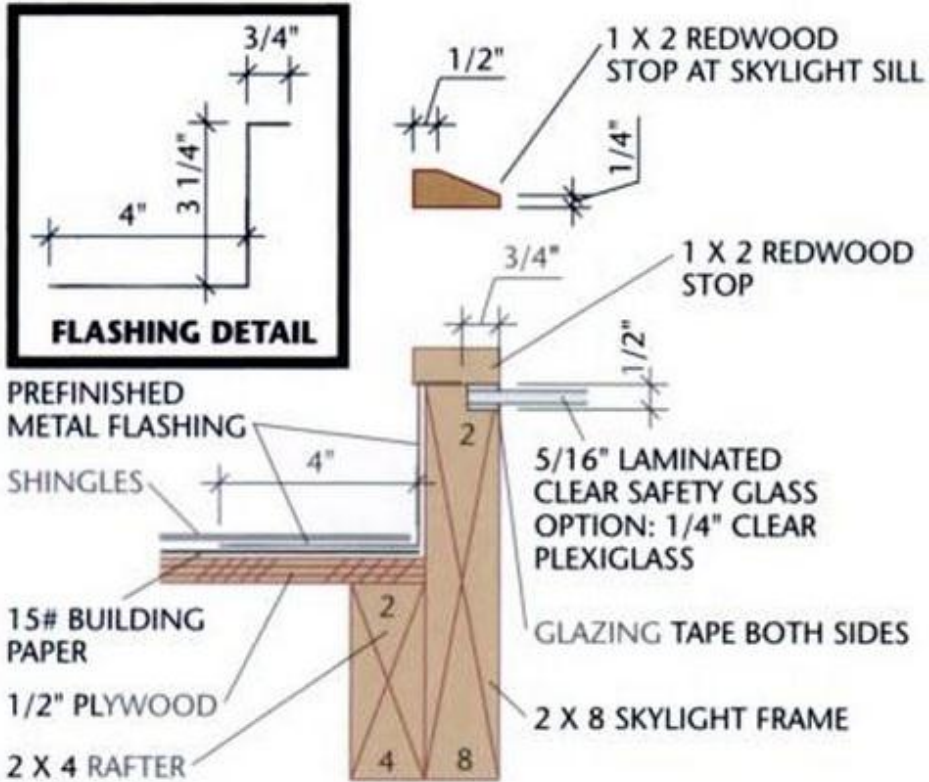

DOOR DETAIL

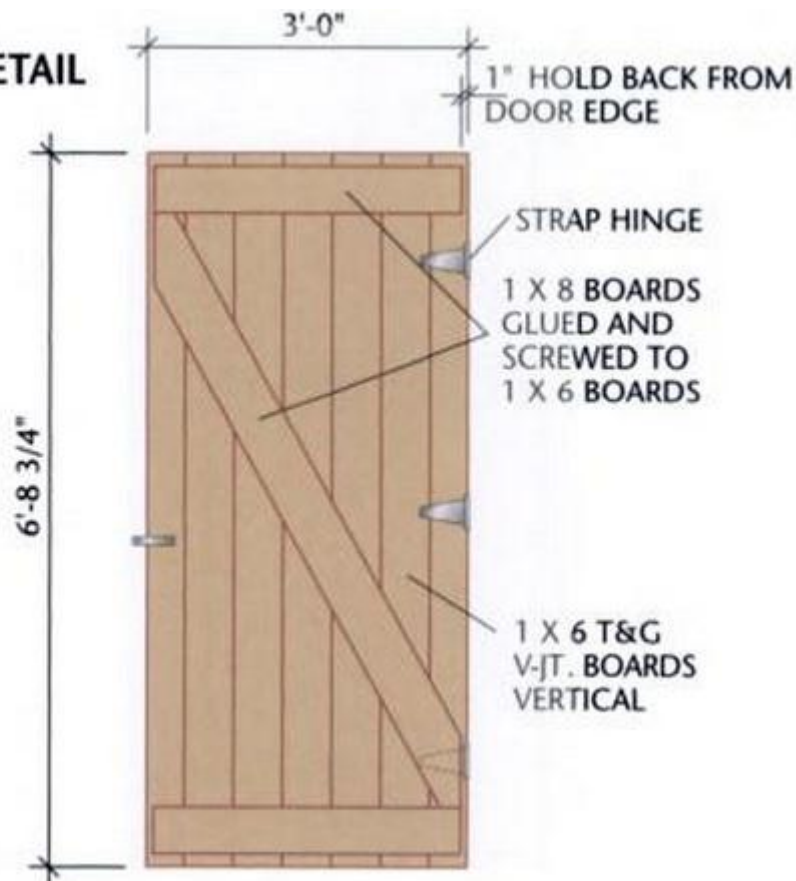

BUILDING THE TIMBER-FRAME GARDEN SHED

Step A: Build the Foundation & Floor Frame

1. Excavate the building site and add a 4" layer of compactible gravel. Tamp the gravel thoroughly, making sure it is level.
2. Cut three 4 × 4 treated timber skids at 120". Arrange and level the skids on the gravel bed, following the FLOOR FRAMING PLAN.
3. Cut 2 × 6 rim joists at 120" and nine joists at 93". Mark the joist layout onto the rim joists, following the plan. Assemble the frame with 16d galvanized common nails—be sure to check each joist for crowning and install it with the crowned edge up.
4. Set the floor frame on top of the skids and measure the diagonals to make sure it's square. Install joist clip angles at each joist along the two outer skids, using 1 1/2" joist hanger nails. Toenail each joist to the center skid with 16d galvanized nails.
5. Install the tongue-and-groove floor sheathing, starting with a full sheet at one corner of the frame. Use 8d galvanized box nails driven every 6" along the edges and every 12" in the field.



Secure the floor frame to the foundation skids with angles (outside skids) and toenails (center skid).



Start the notches with a series of saw cuts, then remove the material with a sharp wood chisel.

Step B: Cut & Notch the Posts

1. Cut six 4 × 4 posts at 90 1/2", making sure both ends are square.
2. The four corner posts have 3 1/2"-long × 1 1/2"- deep notches on two adjacent sides, to accept the girts (note that the notches overlap each other by 1 1/2"). Mark the bottoms of the notches at 46 1/4" from the bottom ends of the posts. Use a square to mark the complete outline of the notches.

The two door-frame posts each have one notch for a girt and one for the door header, also 3 1/2"- long × 1 1/2"-deep. Mark the bottom of the girt notches at 46 1/4" and the bottom of the header notches at 82".

3. Set a circular saw to cut exactly 1 1/2" deep. Cut the notches one at a time: first make the cuts at the top and bottom of the notch, then make a series of cuts to remove the material in between. Clean out the notch with a sharp chisel. Test-fit the notch using the end of a 4 × 4—it should fit snugly.

4. Cut and test-fit the remaining notches.

Step C: Install the Posts

1. Position the post bases using a scrap piece of post. Fasten the bases to the floor with 16d galvanized common nails, making sure the post sides are flush with the outside edges of the floor.

2. Install the door-post bases so the inside faces of the posts are 29" from the floor sides.

3. Set each post in its base, hold it plumb, and tack in one 16d galvanized nail. Nail temporary cross-braces to the post. Use a level to set the post perfectly plumb, secure the braces, then fasten the post to the base with the recommended nails.



Anchor the six posts to the floor with metal post bases. Use galvanized nails to fasten the bases and posts.

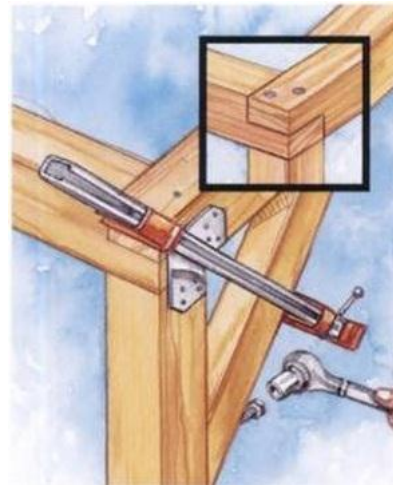

Join the beams with half-lap joints (inset). Fasten the braces to the posts and beams with lag screws.

Step D: Cut & Install the Beams & Braces

1. Cut two 4 × 6 beams at 120" and two at 96", using a circular saw and handsaw or a power miter saw.

2. Cut the notches for the half-lap joints at the beam ends. Measure the width (4" nominal) and depth (6" nominal) of the beams, and mark the

notches to equal the width \times 1/2 of the depth. Orient the notches as shown in the FRAMING ELEVATIONS. Start the cuts with a circular saw, complete them with a handsaw, and smooth the notches with a chisel. Assemble the beams on the ground to test-fit the notches.

3. Set a 96" beam onto the front-wall posts and tack it in place with one 16d nail at each end. Measure the diagonals of the wall frame to make, sure it's square. Drill pilot holes and drive two 60d common nails through each notch and into the post. Install the other 96" beam on the rear posts.

4. Set the 120" beams on top of the short beams, and check the side walls for squareness. Secure each half-lap joint with two 60d nails. Install a post-beam connector on the outside of each corner and on both sides of the door posts, using the recommended nails. Install an L-connector on the inside of each corner (see the EAVE DETAIL), using the recommended nails.

5. Cut eight 4 \times 4 corner braces at 20", mitering the ends at 45°. Position each brace at a corner so the ends are flush with the sides of the post and beam, and secure it with a bar clamp.

6. Drill a counterbored pilot hole 4 1/2" from each end of the braces and fasten them to the beams and posts with 3/8" \times 6" lag screws.

Step E: Install the Girts

1. Cut the 4 \times 4 girts to fit between the posts.

2. To allow the girts to meet at the corner posts, notch both ends of the rear-wall girt and the outside end of each of the front-wall girts. Use a circular saw to cut the notches 1 1/2"-wide \times 1 1/2" deep.

3. Test-fit the girts in the post notches. Apply construction adhesive to the notches and install the girts. Drill pilot holes and endnail the girts with two 20d nails driven through the outsides of the posts.

4. Cut and install the 4 \times 4 door header in the same fashion. Cut the posts for the window rough opening. Position them following the FLOOR PLAN, and fasten them with 20d toenails.

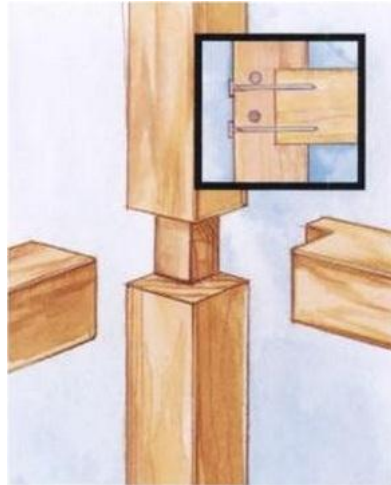

Notch one girt end for each corner joint. Secure the girts to the posts with adhesive and 20d nails (inset).



Install blocks between the two middle rafters, then build the skylight frame from notched 2 x 8s

Step F: Frame the Roof

1. Cut two pattern rafters, following the RAFTER TEMPLATE. Test-fit the rafters using a 2 x 6 spacer block to represent the ridge, then cut the ten remaining rafters.
2. Cut the 2 x 6 ridge board at 120". Draw the rafter layout onto the beams and ridge board, using 24" on-center spacing.
3. Install the rafters. Reinforce the rafter-beam connections with metal anchors on all but the four outer rafters, using the recommended nails.
4. Cut two 2 x 4 collar ties at 58", mitering the ends at 45°. Position the ties on the outside faces of the two middle rafters so they are level and their ends are 1/2" away from the tops of the rafters. Facenail them to the rafters with three 10d common nails at each end.
5. Cut four 2 x 2s to extend from the roof peak to the rafter ends (see the GABLE OVERHANG DETAIL). Nail the 2 x 2s to the rafters with the top edges flush, using 10d nails.
6. Build the skylight frame, starting with the header and sill blocks. Measure from the ends of the two middle rafters and mark their inside faces at 16" and 64". Cut two 2 x 4 blocks to fit between the rafters at these marks. Set the blocks with their inside faces on the marks and their edges flush with the rafters, and endnail them with two 16d nails at each end (the blocks should be 48" apart).
7. Using a router or a table saw, cut a 3/4"-wide x 1/2"-deep continuous notch into the top, corner edge of the skylight frame stock (see the SKYLIGHT DETAIL). Cut the frame pieces to length, mitering the ends at 45°. Position the frame pieces flush with the bottom edges of the rafters and facenail them with 10d nails.

8. Measure the frame at the notches and order the skylight glass to fit. Also order the metal flashing for the skylight frame.

Step G: Install the Siding on the Gable Ends

1. Install the 1 × 8 tongue-and-groove siding on the gable ends, starting at the comers. Hold the siding 3/4" below the bottom of the floor frame and extend it up to the 2 × 2 blocking on the end rafters. Fasten the siding with 8d galvanized finish nails. Cut the boards flush to the insides of the door frame, but do not nail the siding to the door header in this step.

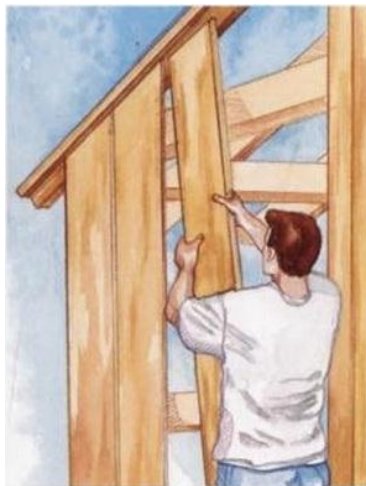

Add the siding to the end walls, fastening it to the rafters and timber framing with two facenails at each support.



Install the subfascia along the eaves, then add the fascia and 1 × 2 trim along the top fascia edges.

Step H: Install the Fascia, Soffits & Remaining Siding

1. Cut and install the 1 × 4 subfascia along the eaves (see the EAVE DETAIL), using 8d box nails. Keep the ends flush with the outsides of the end rafters, and the top edges flush with the top rafter edges.

2. Install the 1 × 6 fascia and 1 × 2 trim along the gable overhangs, then along the eaves, using 8d galvanized finish nails. Hold the fascia 1/2" above the rafters so it will be flush with the sheathing.

3. Rip the 3/8" plywood soffit panels to fit between the wall framing and the fascia (see the EAVE DETAIL). Fasten the soffits to the rafters with 3d galvanized box nails.

4. Cut holes for four soffit vents: locate one vent in each of the two outer rafter bays, on both sides of the building. Install the vents.

5. Install the siding along the side walls. Do not nail the siding to the window header in this step.

Step I: Install the Roofing

1. Install the 1/2" plywood sheathing, starting at a lower corner of the roof—use 8d box nails driven every 6" along the edges and every 12" in the field of the sheets.
2. Attach drip edge along the eaves, then apply 15# building paper over the sheathing. Add drip edge along the gable ends, on top of the paper.
3. Install the asphalt shingles up to the bottom edge of the skylight frame.
4. Add the pre-formed flashing around the skylight frame. Cut the bottom piece 8" longer than the width of the frame. Snip the horizontal flanges and bend the ends so they lie flat against the frame sides (the bottom piece goes on top of the shingles). At each end, drive one roofing nail through the vertical flange into the frame side. Repeat this process to install the side flashing pieces, then the top piece. Seal all of the joints and nail heads with roofing cement.
5. Install the remaining shingles. If desired, install roof vents.



Cut the horizontal flanges of the bottom piece of skylight flashing and wrap the ends around the frame sides.



Lay the glass into the skylight frame and secure it with redwood stops. Use a beveled stop for the bottom piece.

Step J: Complete the Skylight

1. Apply glazing tape to the notches of the skylight frame. Set the glass over the tape, then apply tape along the glass edges (see the SKYLIGHT DETAIL).
2. Using a table saw, circular saw, or hand plane, taper one side of a 26"-long piece of 1 × 2 stop material, as shown in the SKYLIGHT DETAIL.
3. Cut the stops to fit around the frame, using the tapered stop for the bottom (sill) piece. Drill pilot holes and attach the stops with 6d galvanized finish nails.

4. Caulk the nail holes and along the stop edges.

Step K: Build & Install the Window

1. Using 3/4" × 4 1/4" stock, cut the window frame pieces to form a rectangular frame that is 1/2" shorter and narrower than the rough opening. Assemble the frame with 2 1/2" deck screws. Cut and install a 2 × 4 mullion in the center of the frame.

2. Install the window frame in the rough opening, using shims and a level to make sure the frame is plumb and level and the jambs are straight. Fasten the frame with 10d galvanized casing nails.

3. Cut sixteen 1 × 2 stops. Bevel the two outer sill stops as shown in the WINDOW JAMB DETAIL. Attach the inner stops with 6d galvanized finish nails. Order the glass to fit.

4. Install the glass and outer stops, applying glazing tape to the stops on both sides of the glass.



Attach the outer window stops, with the beveled stop at the bottom. Nail the center stops to the mullion.

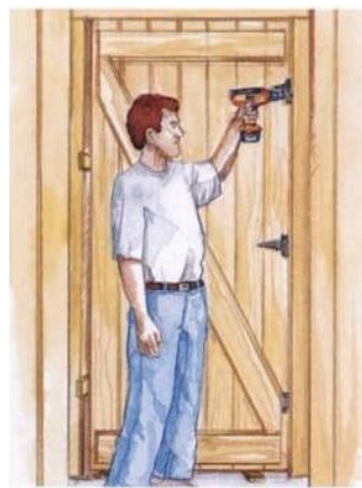

Use shims to set the gaps along the door edges, and mount the door hinges with galvanized screws.

Step L: Build the Door & Install the Trim

1. Cut the head jamb for the door frame at 37 5/8" and the two side jambs at 80 7/8". Position the head jamb over the ends of the side jambs and fasten the pieces with 2 1/2" deck screws. Cut the 1 × 2 stops and install them 3/4" from the inside edges of the frame (see the DOOR JAMB DETAIL). If you want the door to swing out, install the stops 3/4" from the outside edges.

2. Install the frame in the rough opening, using shims and 10d galvanized casing nails. Make sure the frame is square and plumb.

3. Cut seven pieces of 1 × 6 siding at 80 3/4". Fit the boards together with their ends flush, then mark the two end boards for trimming so that the total width is 36". Trim the end boards.

4. Cut the Z-brace boards following the DOOR DETAIL. Lay the door on a flat surface and attach the brace boards using construction adhesive and 1 1/4" wood screws. Install the bottom hinge before the cross brace. Install the remaining hinges and hang the door.

5. Install flashing above the door, nail off the siding, then install the 1 × 3 door trim. Install the 1 × 3 window trim and the 1 × 4 corner trim.