

# GARDEN STORAGE SHED



# GARDEN STORAGE SHED

Is your garage overrun by garden tools, hoses, and empty flower pots? The Garden Storage Shed is an attractive solution that you can build yourself. It has space for lawn and garden tools and a counter that's perfect for potting plants. You can even get a head start on your vegetable and flower gardens in the greenhouse window. The feeling of spaciousness inside belies the shed's 8- x 12-foot exterior dimensions. Straightforward lumber and plywood construction simplifies the project. The easy-to-build barn door, constructed of plywood siding, provides a wide entry to the shed. Inside, clerestory windows and a Plexiglas skylight lend a greenhouse atmosphere to the shed. Want to design storage shelves and bins that meet your unique storage requirements? This plan gives you a good start with deep, easy-access bins for firewood, bark dust or peat moss, and a storage bin for rakes, hoes and brooms.

## MATERIALS LIST

### STRUCTURAL PANELS

QUANTITY	DESCRIPTION
5	1/2 inch x 4 ft x 8 ft APA Rated Sheathing
1	3/4 inch x 4 ft x 8 ft APA A-C Plywood
12	4 ft x 8 ft APA Rated Siding (T1-11)
3	3/4 inch x 4 ft x 8 ft Tongue-and-Groove APA Rated Sheathing for subfloor

### OTHER MATERIALS

QUANTITY	DESCRIPTION
	Gravel or concrete for foundation
470 lin. ft	2x4 lumber (approximate quantity)
104 lin. ft	2x4 treated lumber as needed for floor platform with gravel foundation
200 lin. ft	1x4 lumber trim
18 lin. ft	2x6 lumber
40 lin. ft	1x6 lumber
2 sheets	1/8-inch Plexiglas for skylight (cut each skylight from 30- x 60-inch sheet)
2	36- x 15-inch aluminum awning sash windows
1	30- x 24-inch aluminum awning sash window
	Metal flashing (use 6- x 6-inch flashing for roof and 2- x 2-inch flashing for windows)
	Shingles or roofing material
1 set	Hardware for sliding barn door
2 pair	2-1/2-inch door hinges
2	Magnetic catches
2	Door handles
1 pair	4-inch T-hinges for bench
	Chain support for bench
	Eye bolts
1 tube	Clear caulk for Plexiglas skylight
2 sheets	1/4-inch pegboard (optional)
100 ft	3/4- x 3/4-inch blocking for pegboard
As required	Chicken wire for top of storage bin
As required	Nails and screws (16d galvanized nails are recommended for the floor. Use galvanized nails with plywood siding, and 6d nails with roof sheathing.)
As required	Paint or stain

# PROJECT NOTES

## Preparing the Site and Foundation:

Select the area in your yard where you would like to place the Garden Storage Shed. Make sure the site is level. There are two types of foundations you can use: concrete slab or gravel. If a concrete slab is used, the bottom plates can be anchored to the concrete. In the gravel foundation, floor joists are laid down on the gravel, and a plywood floor is built over the joists. It is important that the joists be treated lumber. Place them 16 inches on center. Apply the plywood flooring before beginning wall construction.

## Shed Construction:

The 8-foot end walls can be fabricated complete with plywood siding on the ground and then lifted into place. Space the studs 16 inches on center. Next, erect framing for the long walls and twin storage bins. Apply APA 303 Siding to the framing. When applying the siding, leave openings for the storage bins and doors. See construction details for window installation.

### Clockwise from upper left:

1. A sliding barn door provides a wide entry to the shed.
2. Inside, skylights and clerestory windows create a greenhouse atmosphere.
3. The door is hung with standard barn door hardware.

When all the walls are up, install the center beam and clerestory. To construct center beam at bottom of clerestory, install outer 2x4, toenailing the 2x4 to lumber framing of the outside wall. Nail rafters of lower roof to the center beam and top plate of the outside wall. Rafters should be spaced 24 inches on center. Nail a second 2x4 to the inside of the first beam, creating a double center beam. Frame the clerestory, allowing space for the windows. Nail clerestory framing to the center beam. Fasten the upper roof rafters to the top plate of the clerestory and top plate of the outside wall. Nail a 2x6 to the rafter ends to finish the overhang. Apply plywood siding to the clerestory and plywood or OSB sheathing on the roof. Install awning windows in the clerestory.

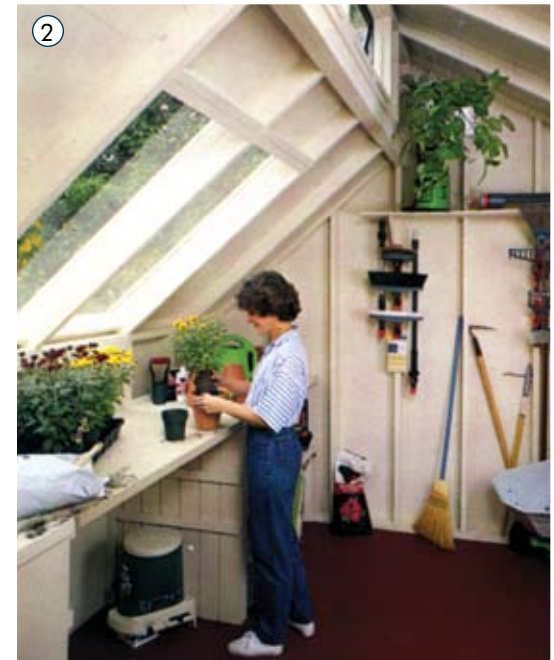

Install Plexiglas skylight panels according to plan details and pictures on following pages. Add lumber trim, flashing and roofing material of your choice. Follow the manufacturer's recommendations for roofing application.

Inside, install the adjustable potting bench between the storage bins. The tops of the bins will also create handy workspace. A pegboard is recommended for storage of hand tools. Install shelving as desired.

Finishing details can also be added to the outside. The plan includes a fold-down bench and a storage bin for long-handled tools. Finish the APA 303 Siding with a paint or stain of your choice.



**Clockwise from upper left:**

- 4.** Construct the nonventing (fixed) skylight frame on site. The framework is routed to receive the Plexiglas panel, which is bedded in silicone caulk. Install the Plexiglas before the caulk sets; the silicone sealant remains permanently flexible.
- 5.** Flex the panel under the drip cap and seat in caulk.
- 6.** Install trim, taking care not to nail through the Plexiglas.



**PANEL LAYOUTS**

(unless otherwise specified, cut one of each panel layout)

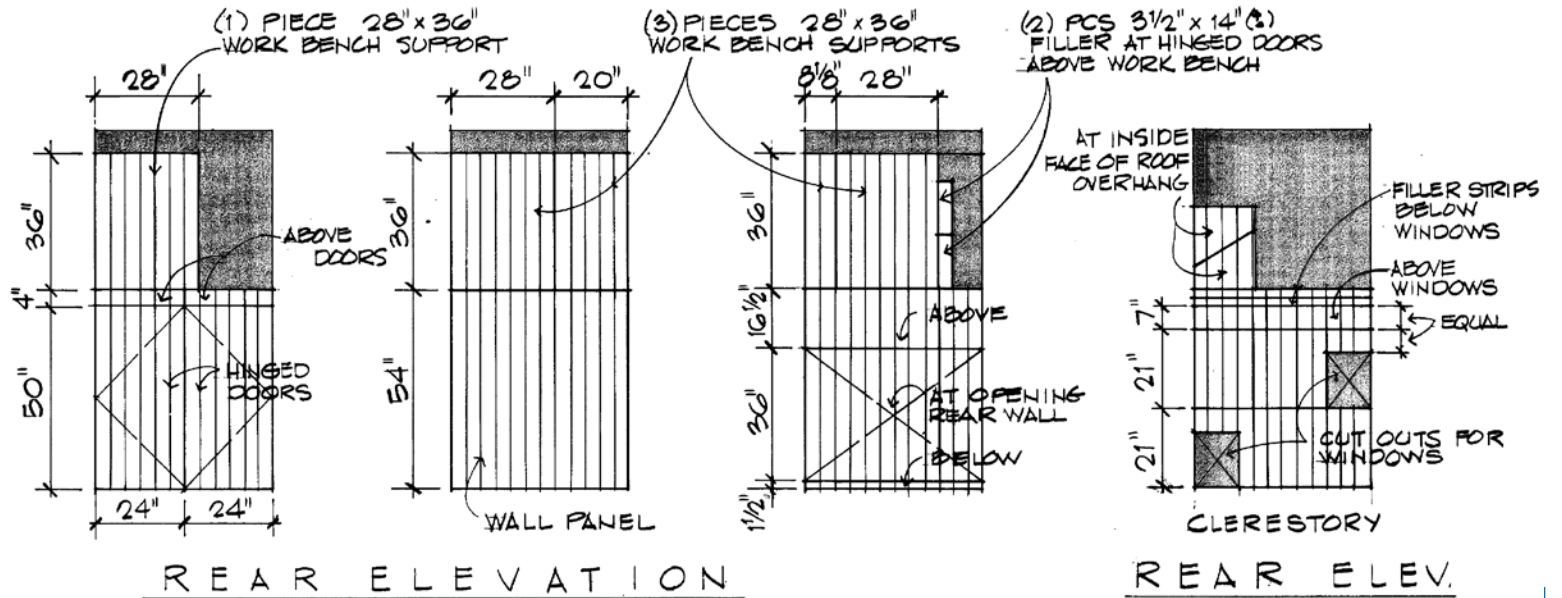

(4) SHEETS 4° x 8° T-1-11 SHEATHING

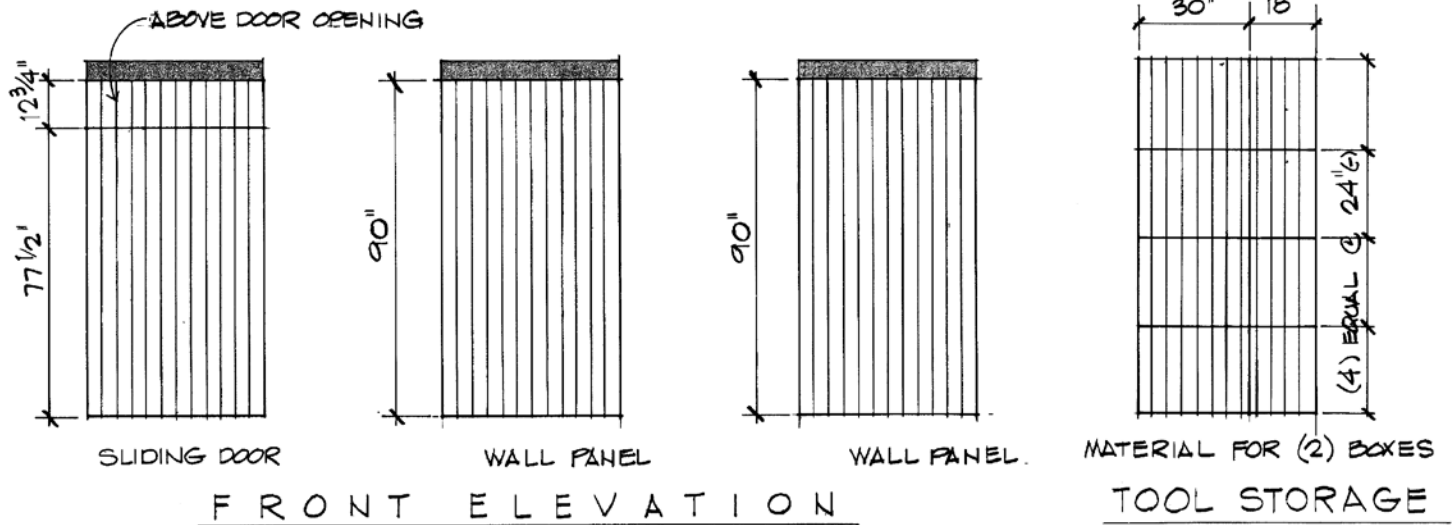

(4) SHEETS 4° x 8° T-1-11 SHEATHING

**PANEL LAYOUTS**

(unless otherwise specified, cut one of each panel layout)

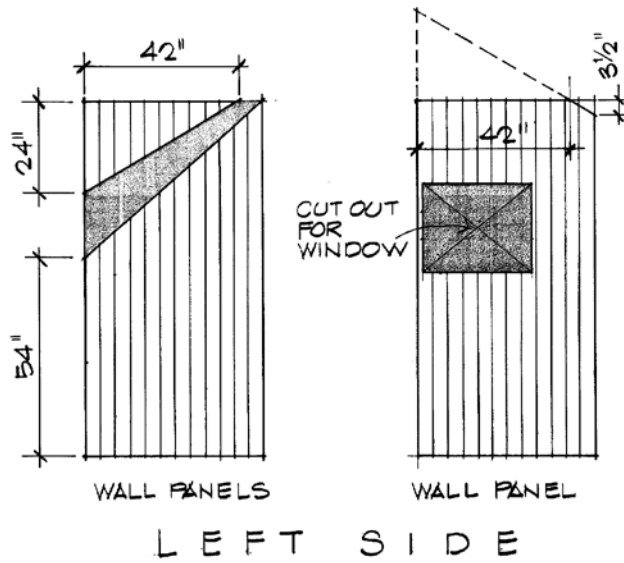
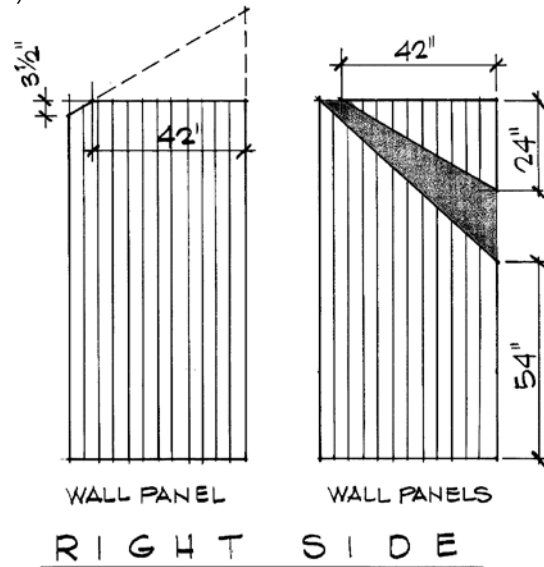

(4) SHEETS 4'x8' T-11 SHEATHING

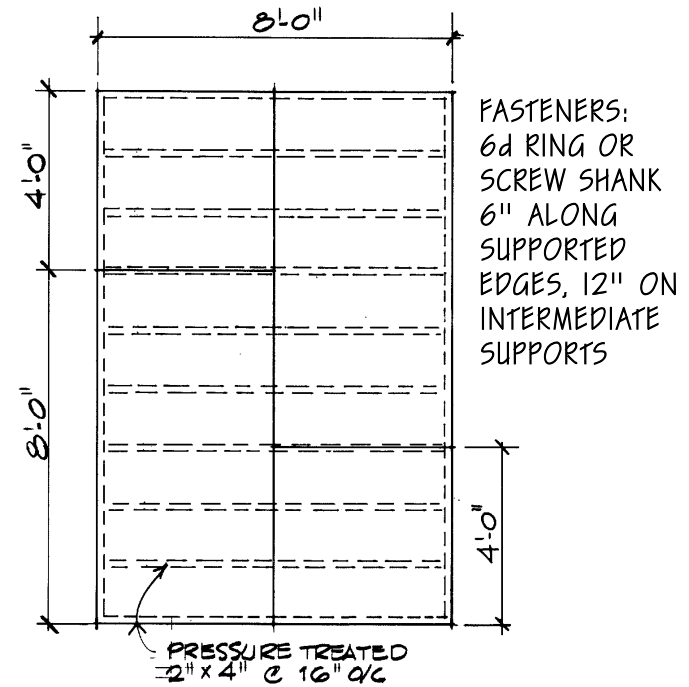

**FLOOR PLATFORM**

(3) SHEETS 4'x8' 3/4" T&G  
SUBFLOOR SHEATHING  
CUT & INSTALL AS SHOWN

## PANEL LAYOUTS

(unless otherwise specified, cut one of each panel layout)

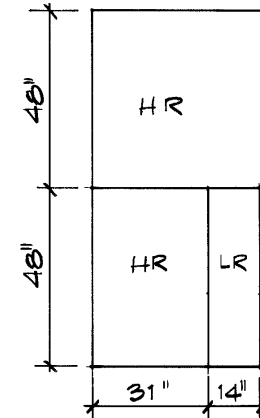
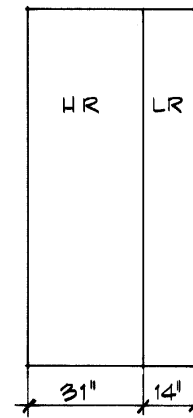
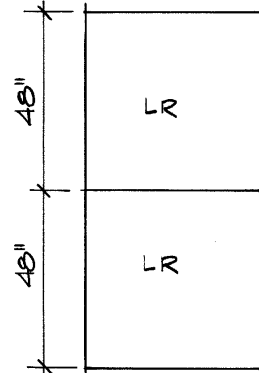
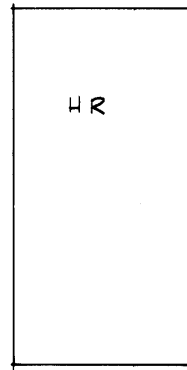

HR = HIGH ROOF  
LR = LOW ROOF

## ROOF SHEATHING

(4) SHEETS 4° x 8° 1/2" SHEATHING

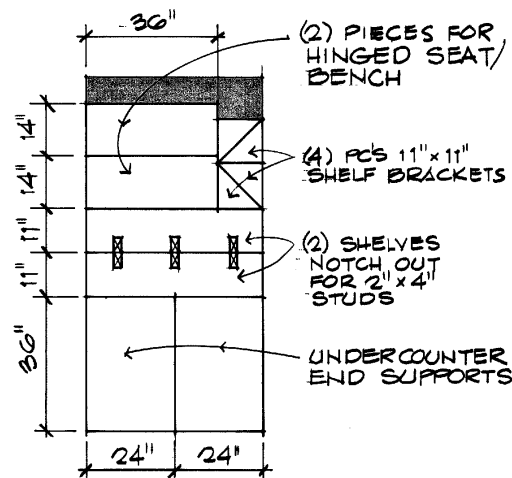

(1) SHEET 4° x 8° 1/2" SHEATHING

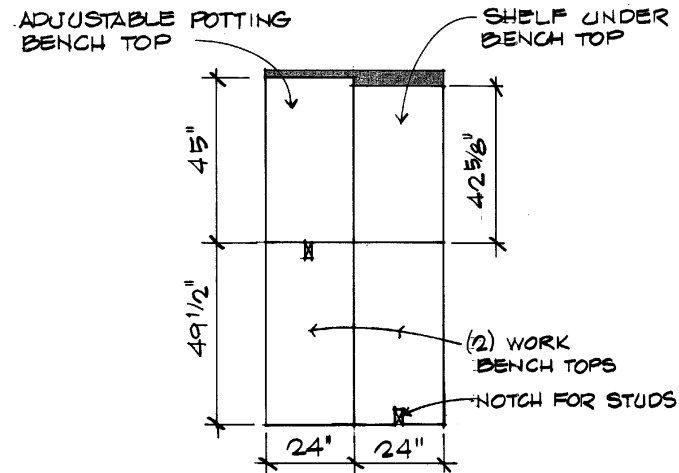

(1) SHEET 4° x 8° 3/4" AC

## WORK BENCHES

Elevation Left Side

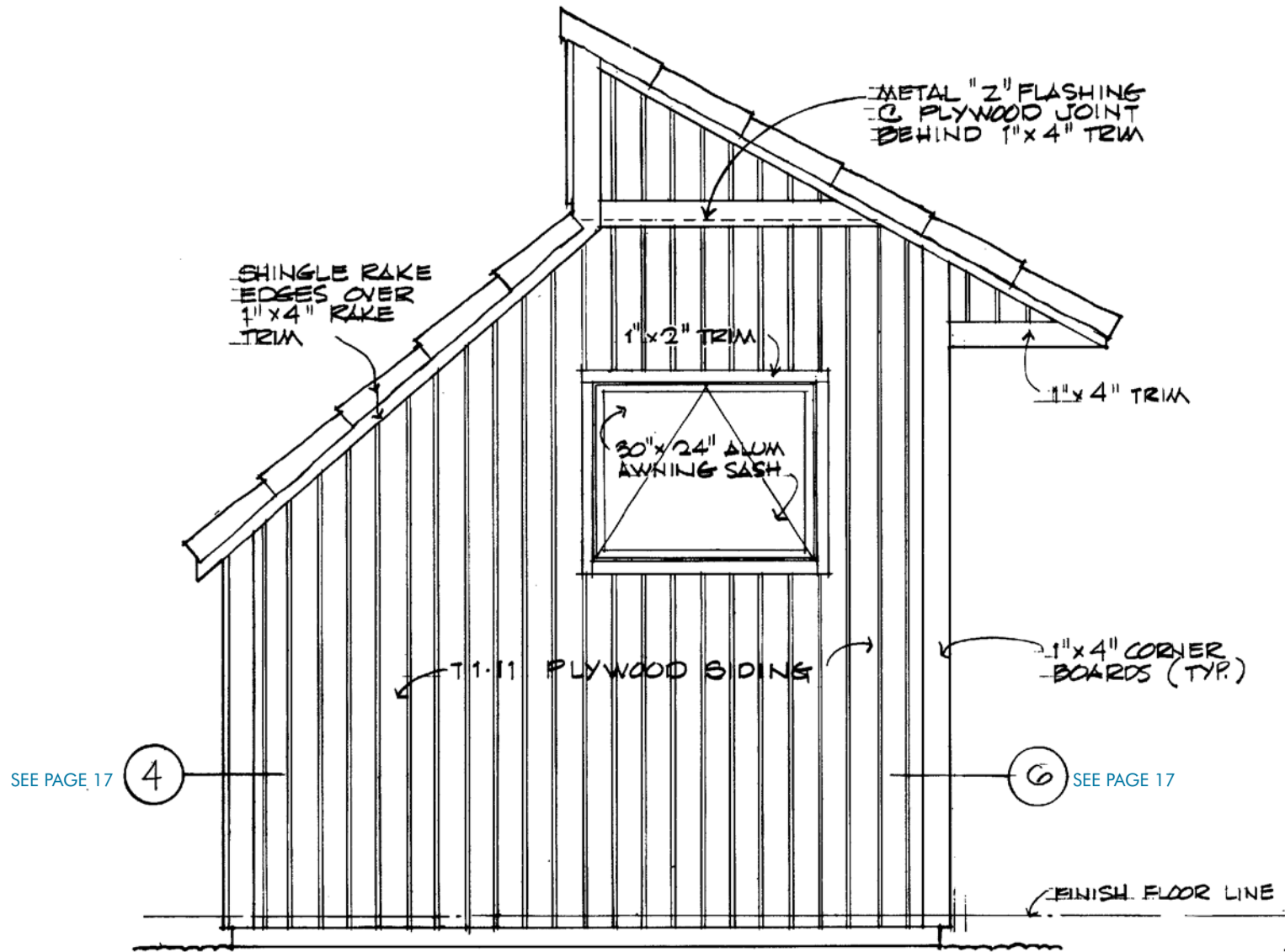

Elevation Front

SEE PAGE 13



SEE PAGE 14



SEE PAGE 15

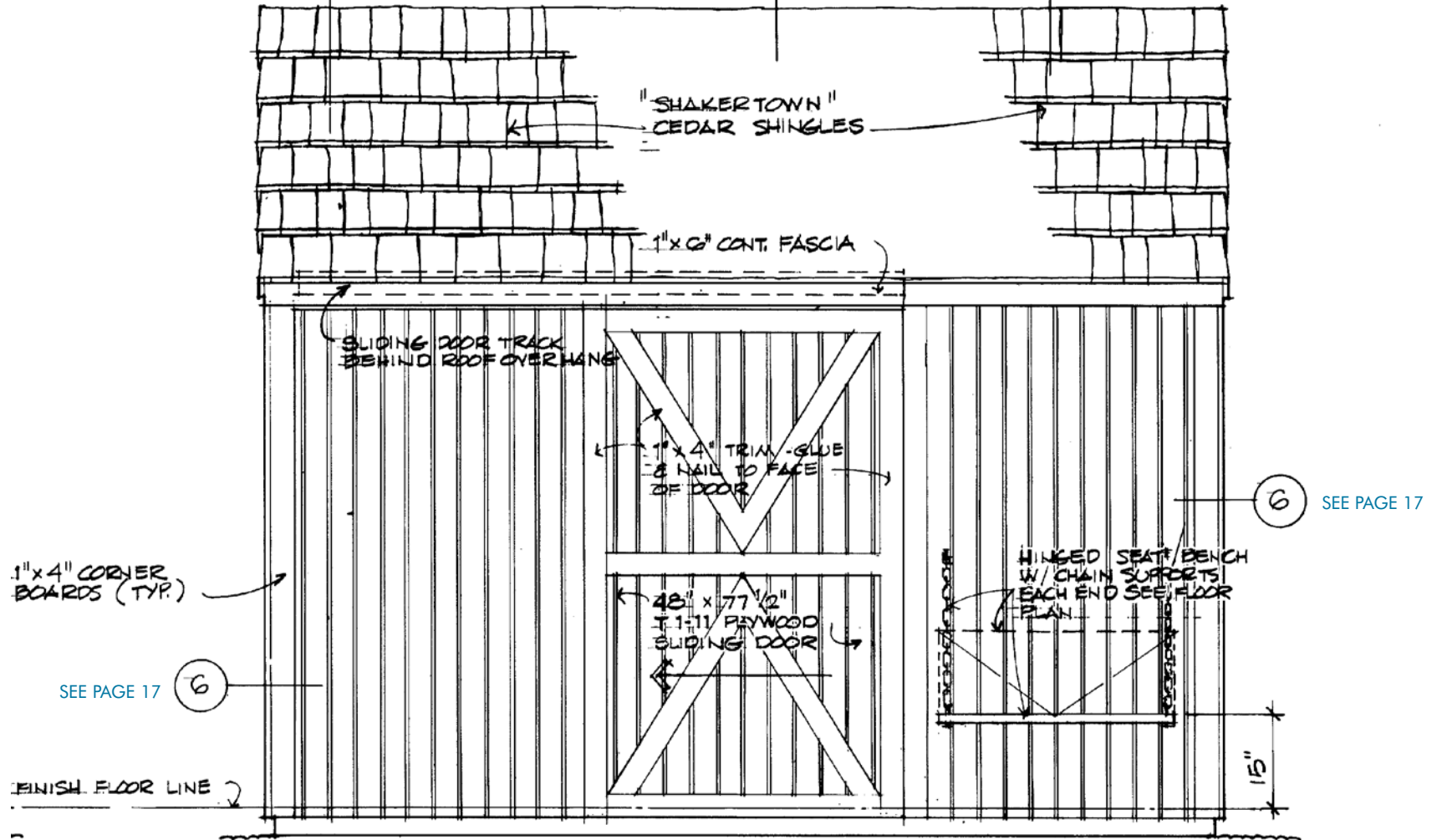

Elevation Right Side

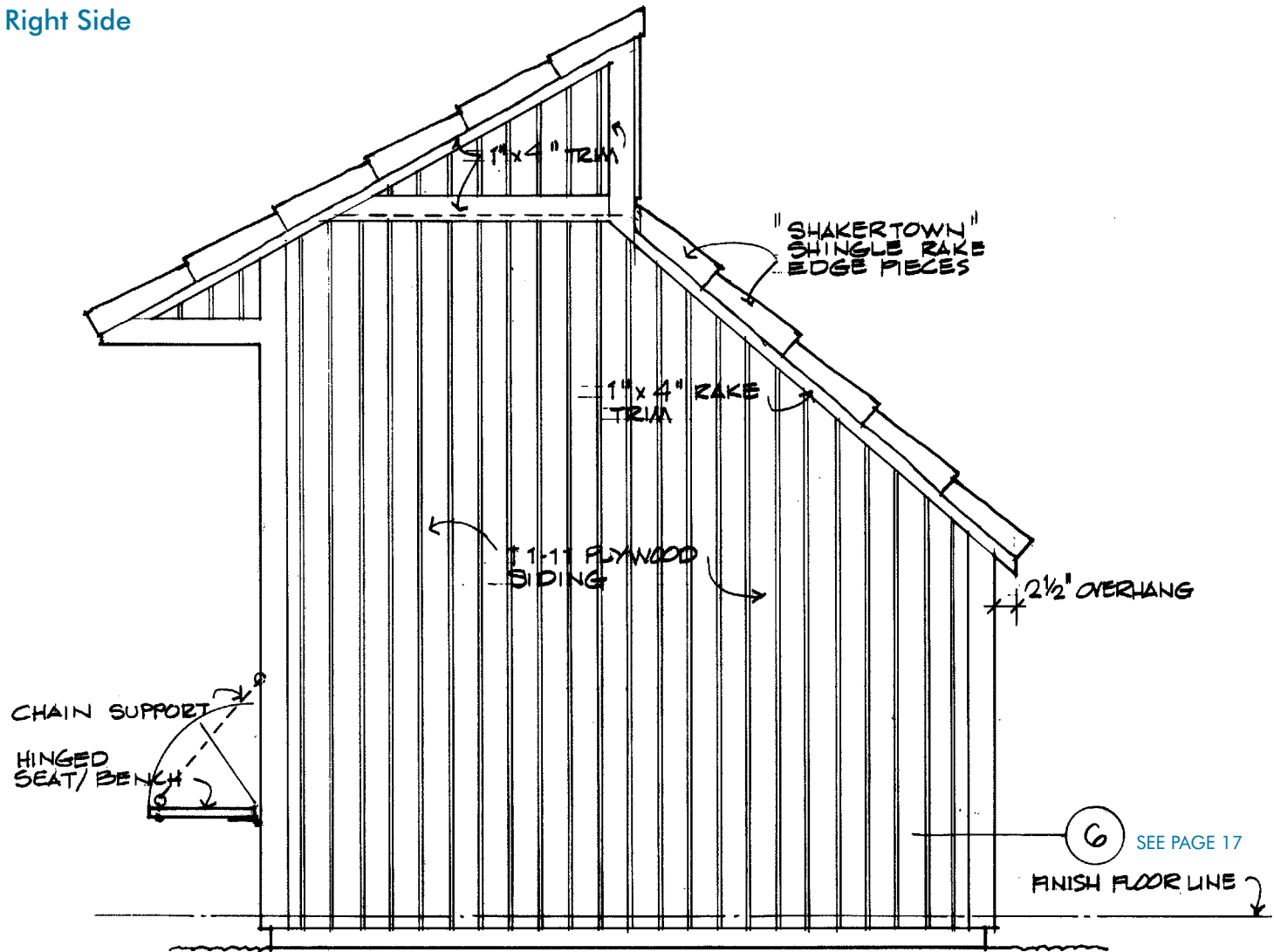

# Elevation Rear

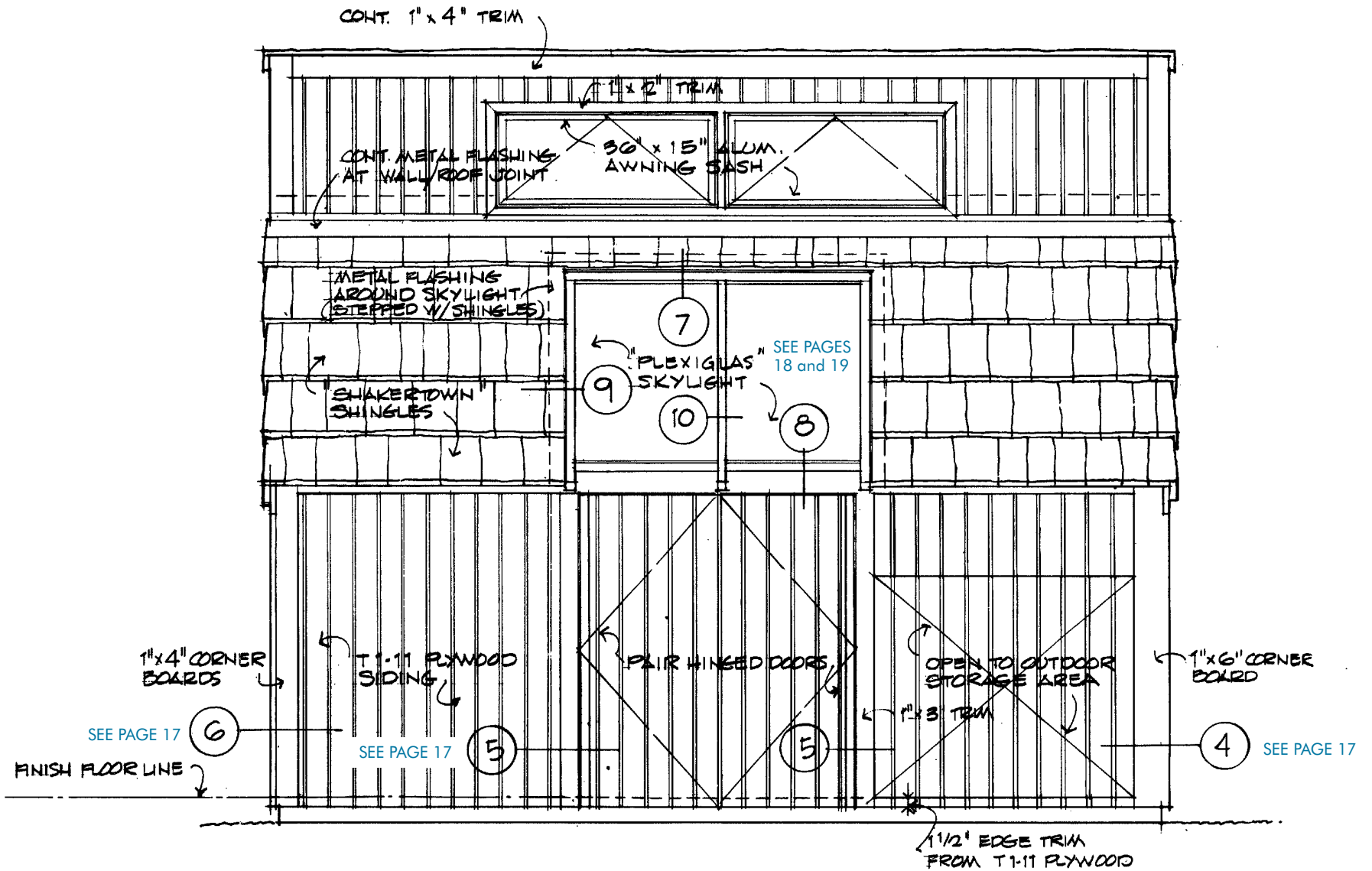

# Floor Plan

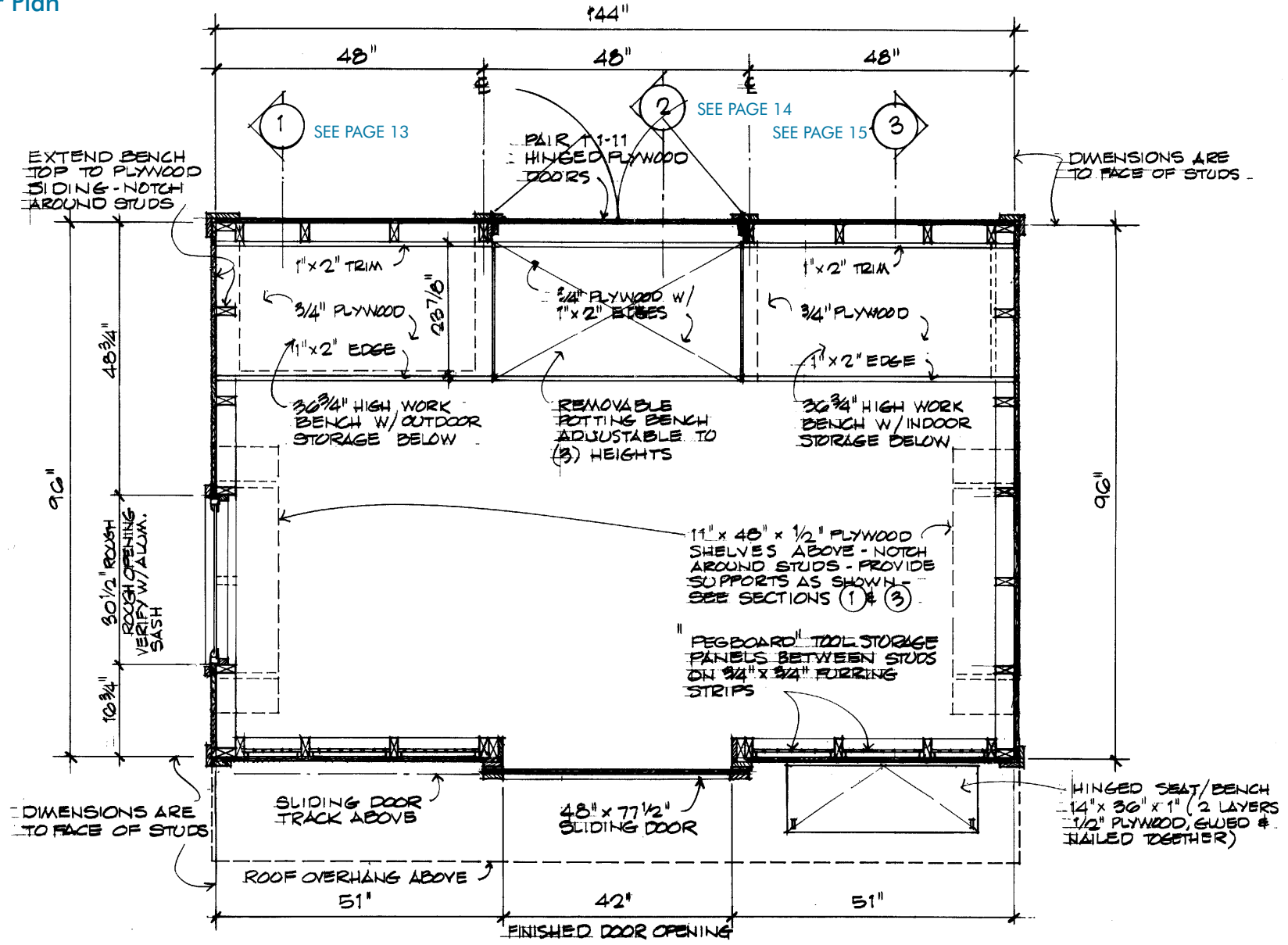



Section ②

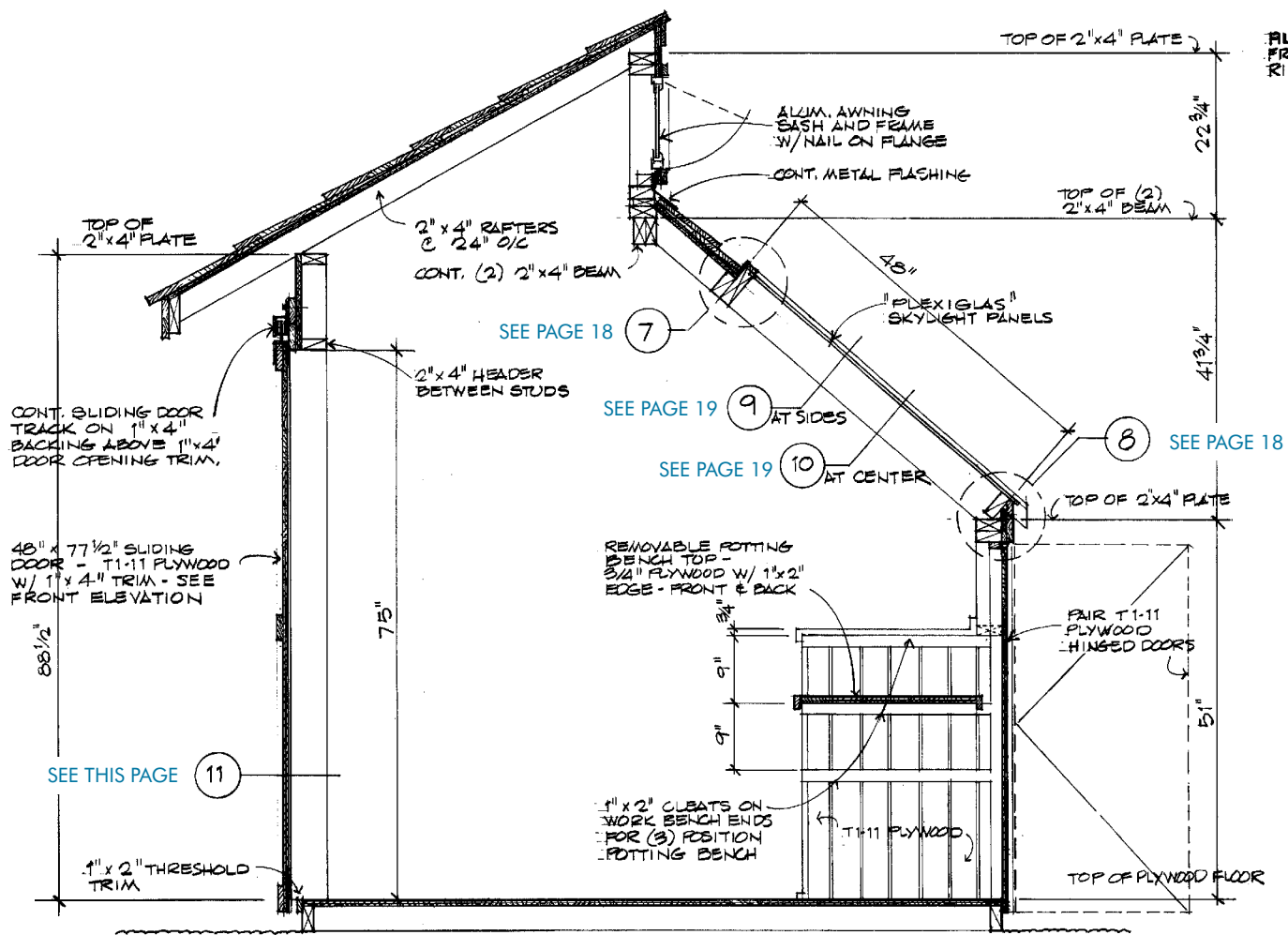
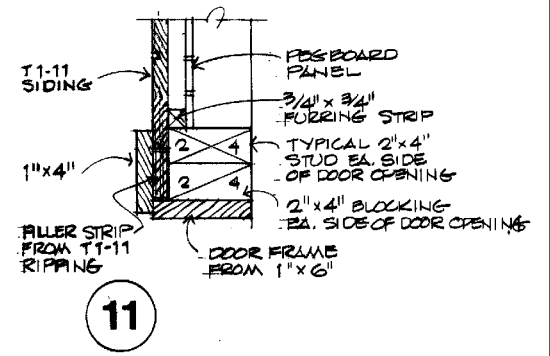

SEE PAGE 18

SEE PAGE 19

SEE PAGE 19

SEE PAGE 18

SEE THIS PAGE

Section ③

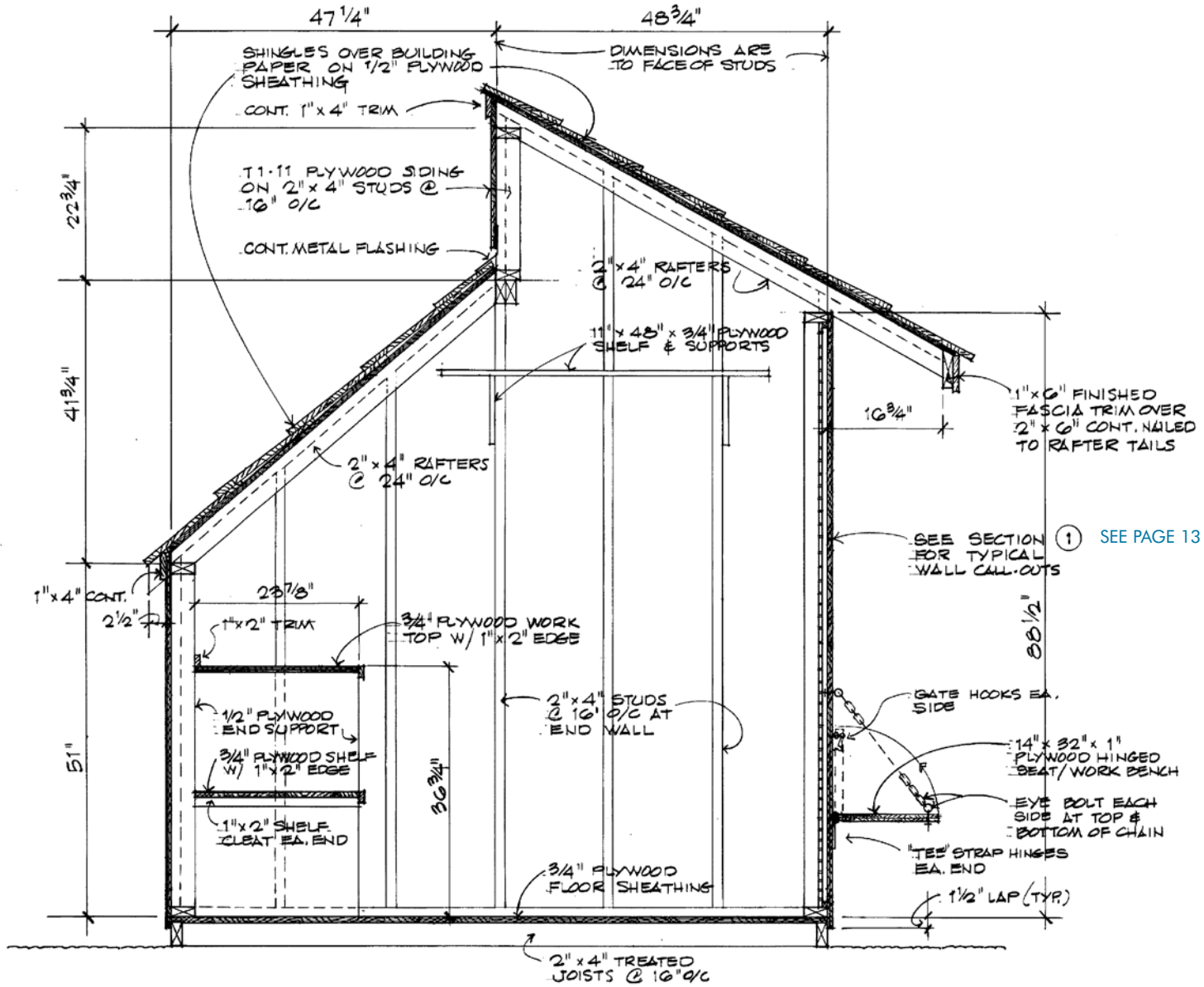

# End Wall Framing Layout

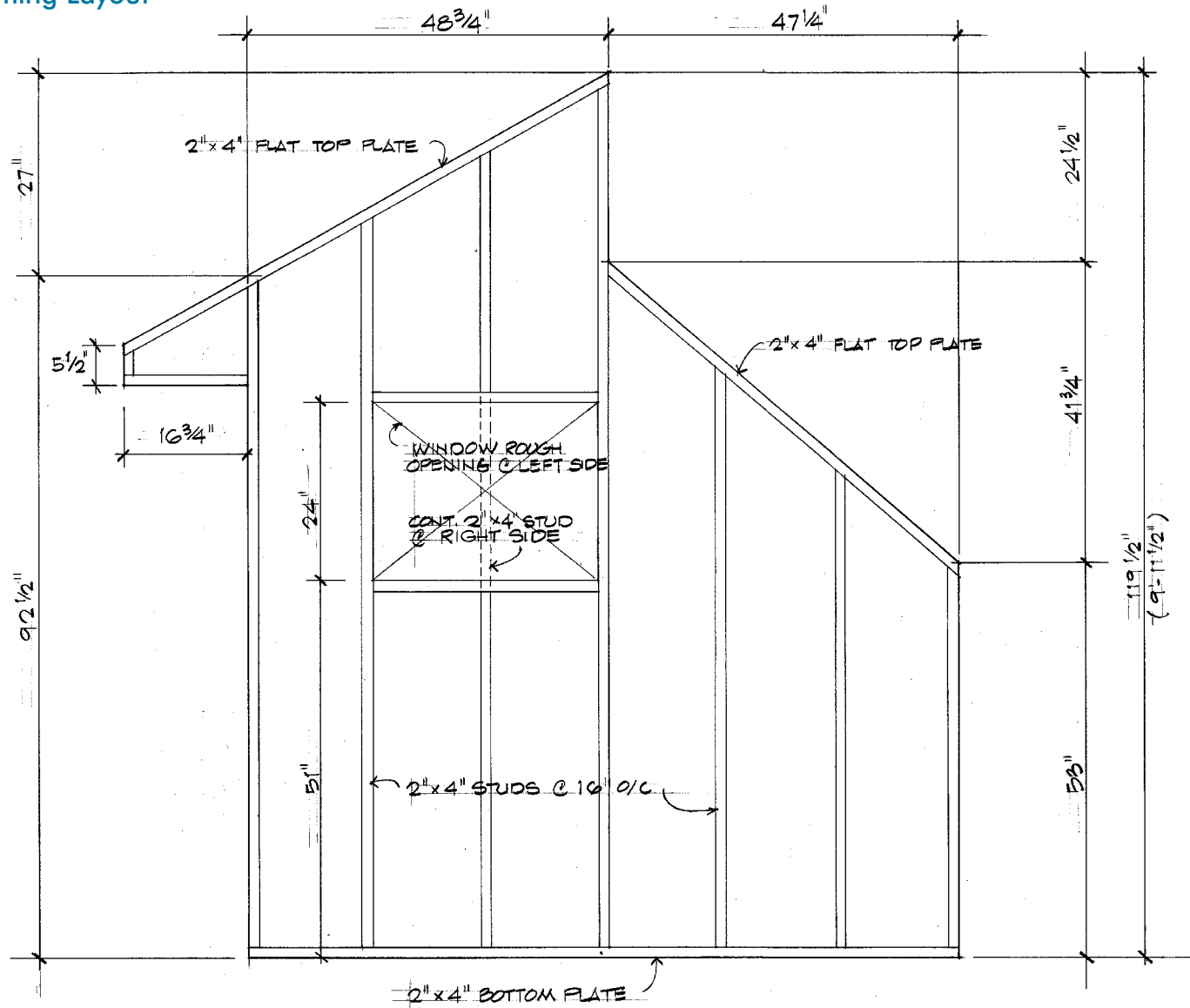

# Plan Below Bench Tops

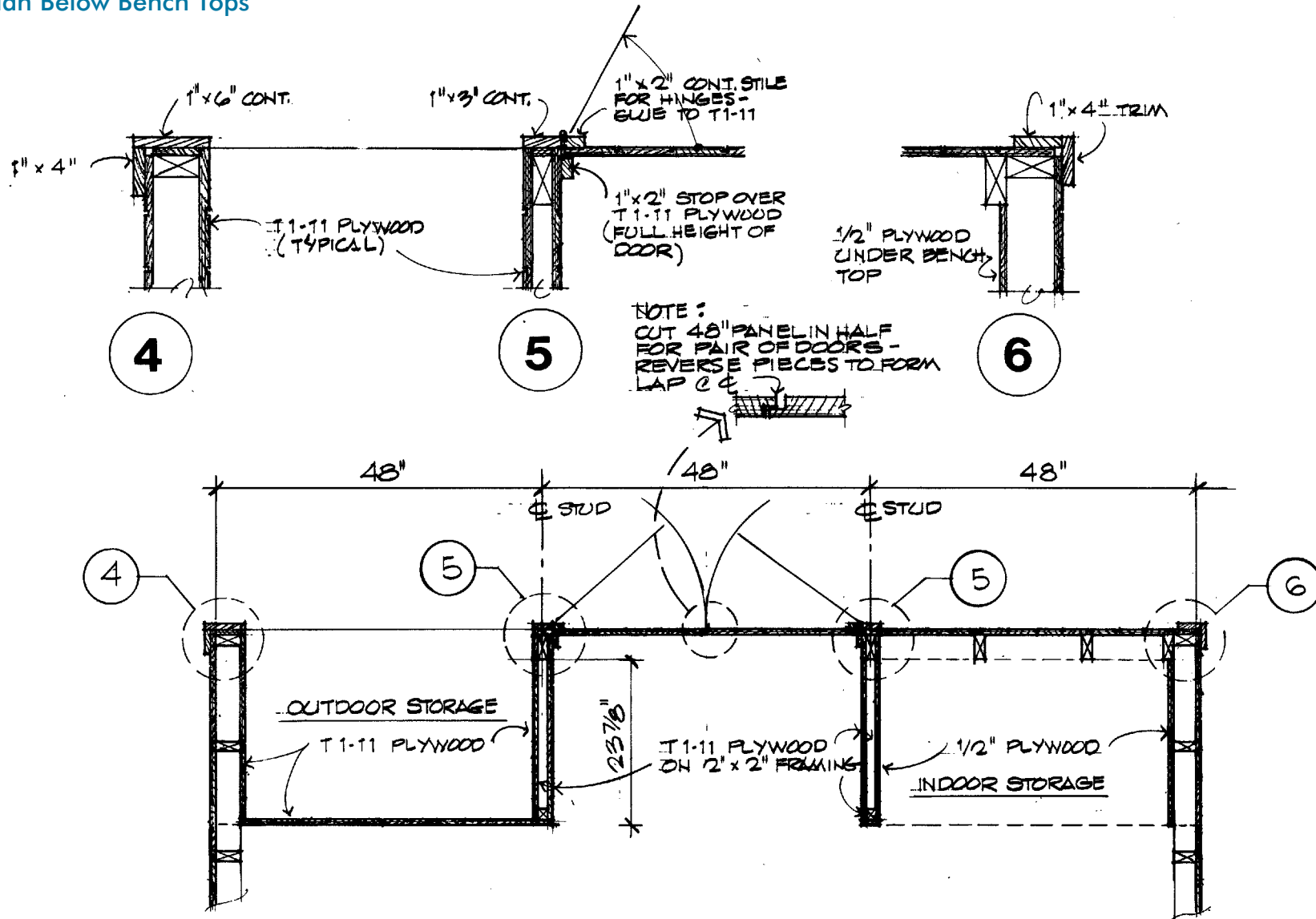

# Roof Details

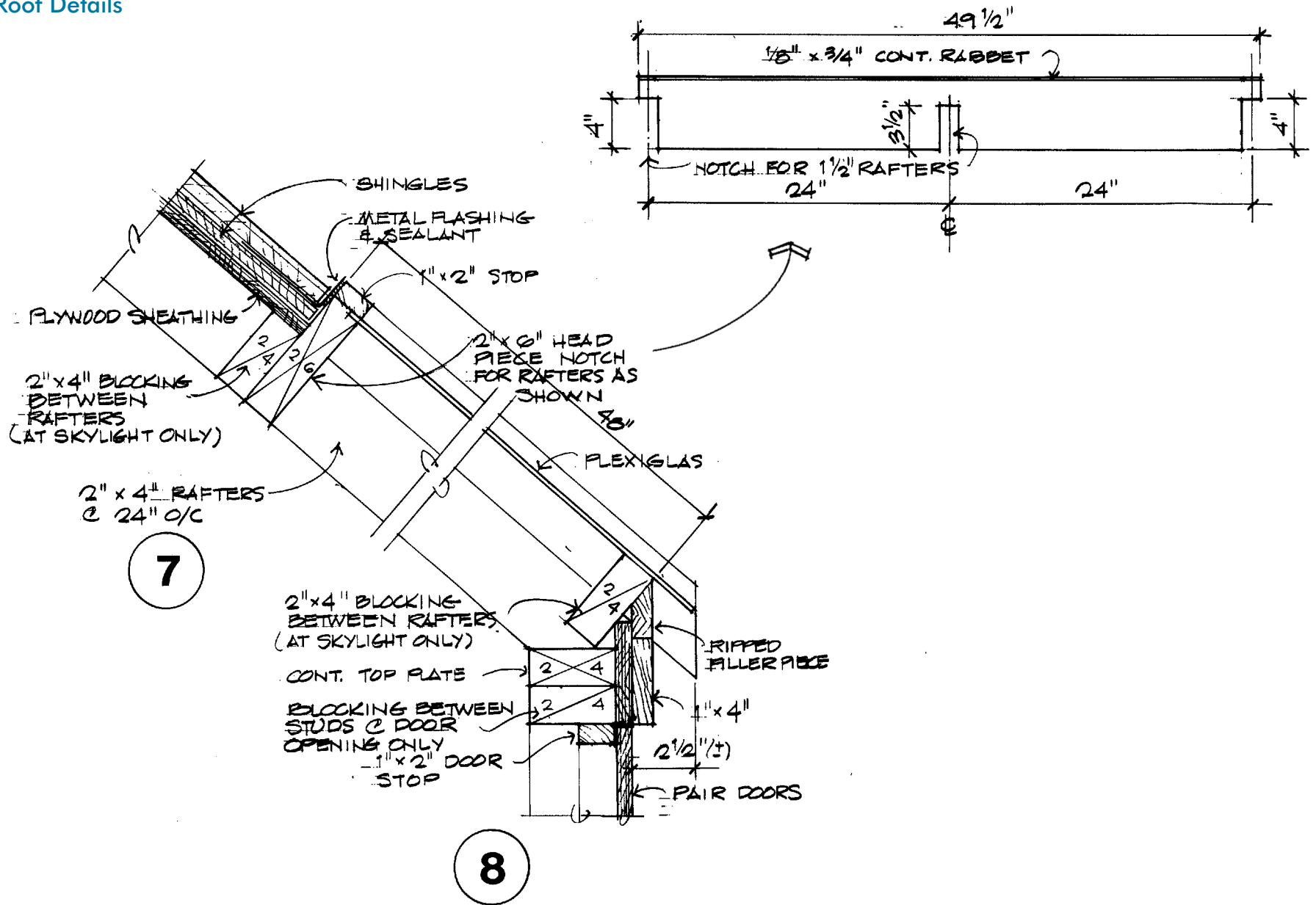

## Plexiglas Skylight

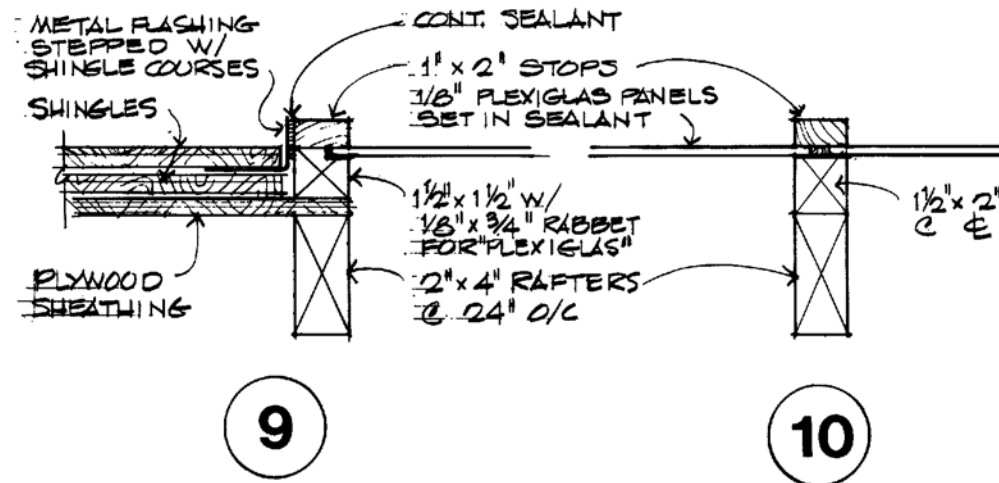

# Garden Tool Storage Box

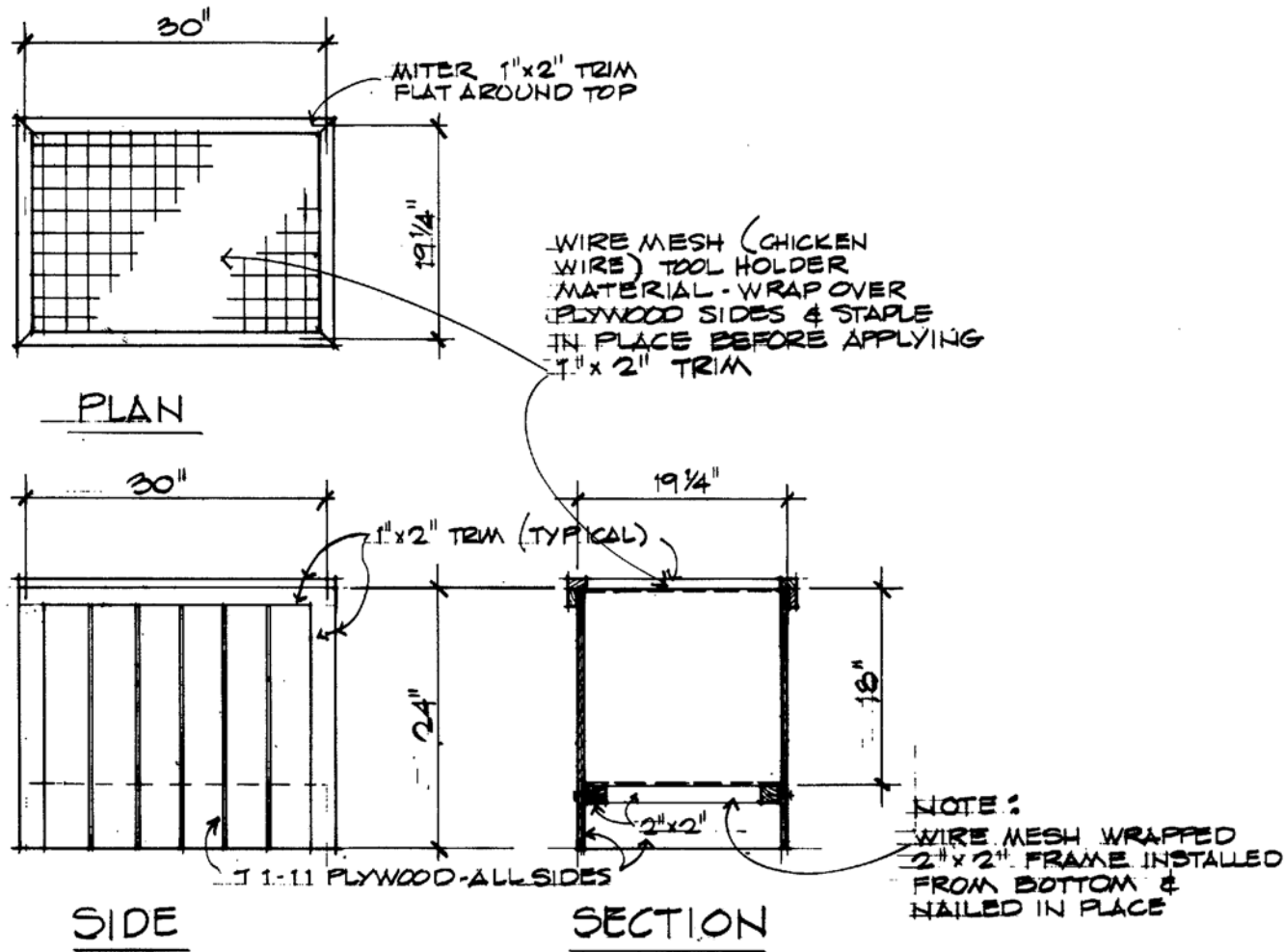

# BUILDING HINTS

These general hints will help you achieve the best possible results in working with APA wood structural panel products. They apply not only to this plan but to all projects you may undertake using APA trademarked panels. Since building methods and interpretation of suggestions may vary, APA cannot accept responsibility for results of an individual's project efforts.

**PLANNING.** Before starting, study the plan carefully to make sure you understand all details.

**MAKING LAYOUT.** Following the panel layout, draw all parts on the panel using a straightedge and carpenter's square for accuracy. Use a compass to draw corner radii. Be sure to check the width of your saw cut and allow for saw kerfs when plotting dimensions.

**CUTTING.** When hand-sawing, support panel firmly with the best side facing up. Use a 10 to 15 point cross-cut saw. Use a fine-toothed coping saw for curves. For inside cuts, start hole with a drill and use a coping or keyhole saw. When power sawing on a radial or table saw, the best side of the panel should be face up. A plywood blade works best, but a sharp combination blade may be used. When using a portable power saw, the best side of the panel should be down. For curved cuts, use a jigsaw, bandsaw or saber saw. Be sure the blade enters the face of the panel. Use the finest tooth possible for a smooth and even cut. For prolonged cutting of nonveneer panels and those containing layers of reconstituted wood, a carbide-tipped blade is suggested.

Reduce panel to pieces small enough for easy handling with first cuts. Plan to cut matching parts with the same saw setting. Scrap lumber clamped or tacked securely in place beneath the panel prevents splintering on the back side.

Overlaid panels can be worked in the same manner as regular grades with these exceptions: sawing and drilling should always be done with the cutting edge of the tool entering the panel face. To minimize chipping at the point of tool exit, use a piece of scrap wood as a backup or place tape along the line of the cut.

**DRILLING.** Support panel firmly. Use brace and bit for larger holes. When point appears through panel, reverse and complete hole from back. Finish slowly to avoid splintering.

**PLANING.** Remember, edge grain of the panel runs in alternate directions so plane from ends toward center. Use shallow set blade.

**SANDING.** Many APA panels are sanded smooth in manufacture – one of the big time-savers in their use – so only minimum surface sanding is necessary. You may find it easier to sand cut edges smooth before assembling each unit. Use medium or finer sandpaper before sealer or flat undercoat is applied. Use fine sandpaper after sealing and in direction of grain only.

**ASSEMBLY.** Construction by section makes final assembly easier. Drawers, cabinet shells and compartments, for example, should be handled as individual units. For strongest possible joints, use glue with screws or nails. Check for a good fit by holding pieces together. Contact should be made at all points for lasting strength. Mark nail location along edge of piece to be nailed. In careful work where nails must be very close to an edge, predrill using a drill bit slightly smaller than nail size. Always predrill for screws.

Apply glue to clean surfaces according to manufacturer's instructions. Press surfaces together until bead appears. Check for square, then nail and apply clamps if possible to maintain pressure until glue sets. For exterior exposure, use resorcinol-type (waterproof) glue; for interior work, use liquid resin (white) or urea resin-type glues. Other glues are available for special gluing needs.

## **FINISHING FOR INTERIOR USE.**

Little, if any, surface preparation is usually required. Sanded panels require only light sanding to remove blemishes or to smooth fillers which might be used to patch any dents or openings in the surface. Sand in the direction of the grain only with fine sandpaper. If an opaque finish is to be used, cover any knots, pitch streaks, or sap spots with shellac or a stain-resistant sealer. Do not apply finishes over dust, glue, or spots of oil.

Three types of finishing systems may be used for interior applications: paints, stains and natural finishes.

When using paint systems, a solvent-thinned (oil-based) primer should be used to minimize grain raise and prevent staining. Gloss and semi-gloss enamel top coat provide a washable, durable surface. The top coat may be oil-based or alkyd-based (solvent-thinned) or latex (water-thinned), provided it is compatible with the primer.

Panels used for natural finishes should be carefully selected for pattern and appearance. For the most natural appearance, use two coats of a clear finish, such as a urethane, varnish or clear sealer. To pleasantly subdue any grain irregularities or repairs, a light stain finish may be applied either by color toning, which uses companion stain and non-penetrating sealer, or light staining, which uses a pigmented sealer, tinting material (stain, thin enamel or undercoat) and finish coat (varnish or lacquer). Finish Medium Density Overlaid (MDO) panels with solid-color acrylic latex stain or a two-coat paint system (primer plus companion top coat).

## **FINISHING FOR EXTERIOR USE.**

A top quality stain or paint will help maintain the panel's appearance and protect it from weathering. Since end grain absorbs and loses moisture rapidly, panels should be edge-sealed to help minimize possible damage. Use paint primer to seal panels to be painted, or use a paintable water-repellent preservative for panels which are to be stained.

For rough or textured panels, either high quality stain or acrylic house paint systems are recommended. Use a solvent-thinned semi-transparent stain for maximum grain show-through. Use only acrylic latex solid-color stain when it is desirable to hide the grain and color of the wood surface, but not its texture. Maximum protection of the wood is obtained by using a house paint system which consists of a stain-resistant primer and one or more acrylic latex top coats. Finish Medium Density Overlaid (MDO) panels with solid-color acrylic latex or a two-coat paint system (primer plus companion top coat).

Best performance is achieved by applying the first coat of finish by brushing. If the first coat of finish is sprayed on, it should be back-brushed or back-rolled to work it well into the wood surface. Additional coats may be sprayed without back-brushing.

Whatever finishing method is used – paint or stain – always use top quality materials and follow the manufacturer's instructions.