

# Colonial Washstand Circa 1760

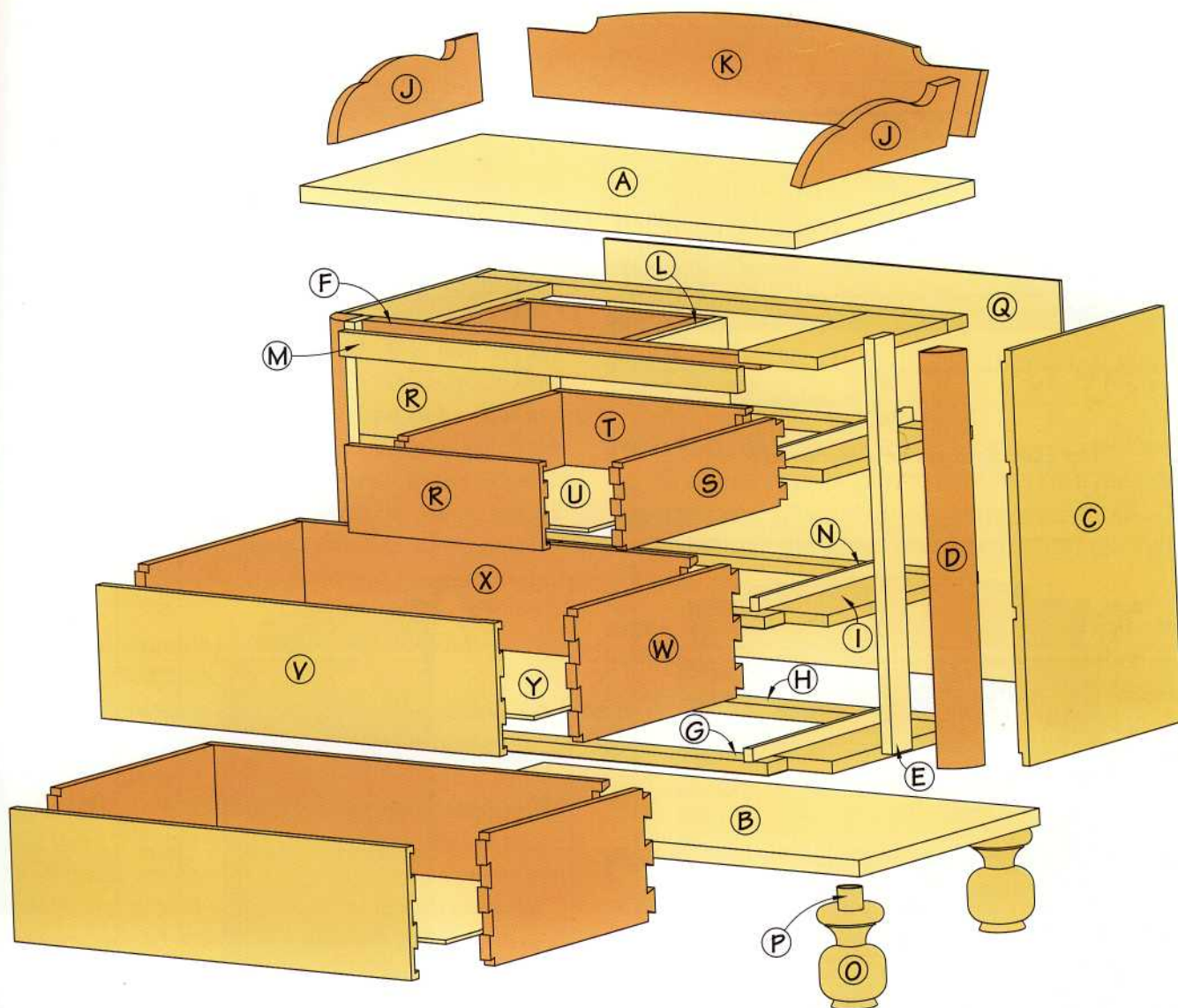

I found the original of this piece while on vacation on Jekyll Island in Georgia. It was one of a pair in a conference room at the Jekyll Island Club Hotel, part of the island's historic district, and was probably

made during the middle of the eighteenth century. It was, as ours is, made from pine. The patina was a lovely buttery color. Close inspection failed to reveal traces of any finish other than many years of wax polishing. Most



## MATERIALS LIST

### Colonial Washstand

No.	Letter	Item	Dimensions T W L	No.	Letter	Item	Dimensions T W L
1	A	Top	$\frac{3}{4}$ " $\times$ 18" $\times$ 36"	1	N	Trim	$\frac{3}{4}$ " $\times$ 1 $\frac{1}{2}$ " $\times$ 29"
1	B	Base	$\frac{3}{4}$ " $\times$ 18" $\times$ 36"	6	O	Drawer Guides	$\frac{3}{4}$ " $\times$ 1 $\frac{3}{4}$ " $\times$ 15"
2	C	Sides	$\frac{3}{4}$ " $\times$ 15 $\frac{1}{4}$ " $\times$ 25"	4	P	Feet	4" $\times$ 4" $\times$ 6"
2	D	Pilasters	2" $\times$ 2" $\times$ 25"	4	Q	Feet	$\frac{3}{4}$ " $\times$ 1 $\frac{1}{4}$ " dowels
2	E	Pilaster Fillers	$\frac{3}{4}$ " $\times$ 2" $\times$ 25"	1	R	Back	$\frac{1}{4}$ " $\times$ 24 $\frac{1}{2}$ " $\times$ 33 $\frac{1}{8}$ "
1	F	Web Frames	$\frac{3}{4}$ " $\times$ 1 $\frac{1}{4}$ " $\times$ 29"	2	S	Drawer Front	$\frac{3}{4}$ " $\times$ 5 $\frac{1}{4}$ " $\times$ 14 $\frac{1}{4}$ "
3	G	Web Frames	$\frac{3}{4}$ " $\times$ 2" $\times$ 29"	4	T	Drawer Sides	$\frac{3}{4}$ " $\times$ 5 $\frac{1}{4}$ " $\times$ 16 $\frac{1}{2}$ "
4	H	Web Frames	$\frac{3}{4}$ " $\times$ 2" $\times$ 34 $\frac{1}{2}$ "	2	U	Drawer Backs	$\frac{3}{4}$ " $\times$ 4 $\frac{3}{4}$ " $\times$ 14 $\frac{1}{4}$ "
9	I	Web Frames	$\frac{3}{4}$ " $\times$ 5 $\frac{3}{4}$ " $\times$ 13"	2	V	Drawer Bottoms	$\frac{1}{4}$ " $\times$ 16" $\times$ 13 $\frac{1}{4}$ "
2	J	Gallery	$\frac{3}{4}$ " $\times$ 5" $\times$ 16"	2	W	Drawer Front	$\frac{3}{4}$ " $\times$ 8" $\times$ 29"
1	K	Gallery	$\frac{3}{4}$ " $\times$ 6" $\times$ 33"	4	X	Drawer Sides	$\frac{3}{4}$ " $\times$ 8" $\times$ 16 $\frac{1}{2}$ "
1	L	Drawer Partition	$\frac{3}{4}$ " $\times$ 6" $\times$ 15 $\frac{1}{2}$ "	2	Y	Drawer Backs	$\frac{3}{4}$ " $\times$ 7 $\frac{1}{2}$ " $\times$ 29"
1	M	Facing	$\frac{3}{4}$ " $\times$ 1 $\frac{1}{2}$ " $\times$ 5 $\frac{1}{4}$ "	2	Z	Drawer Bottoms	$\frac{1}{4}$ " $\times$ 16" $\times$ 27"

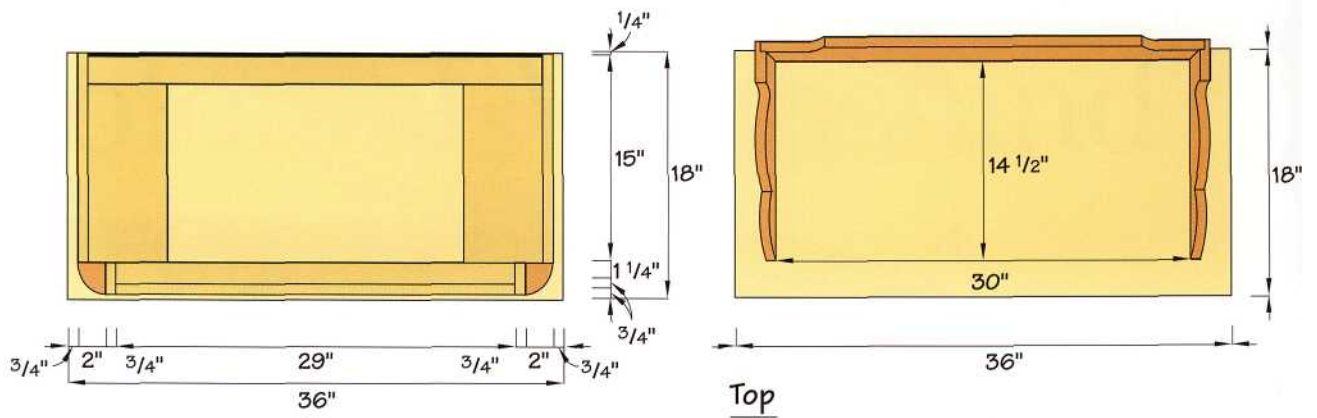

Top (top and gallery removed)

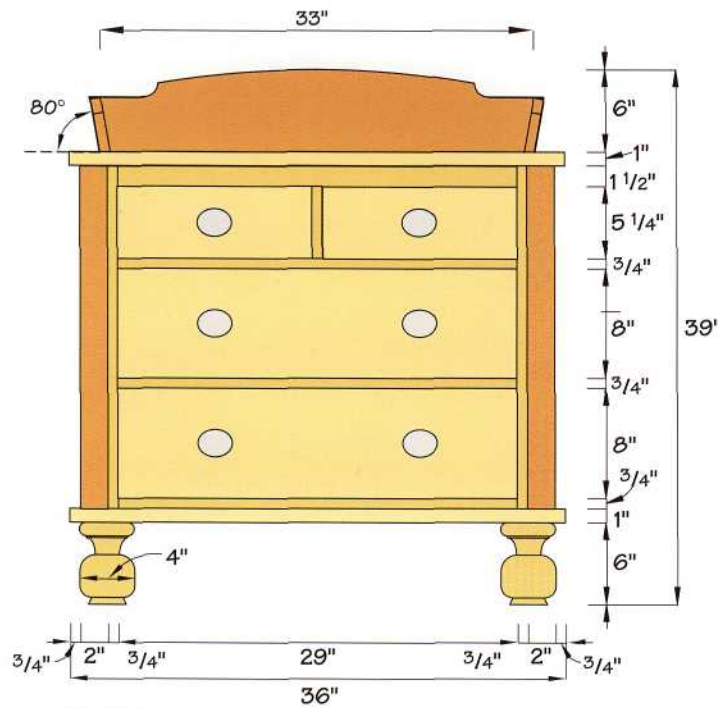

Front

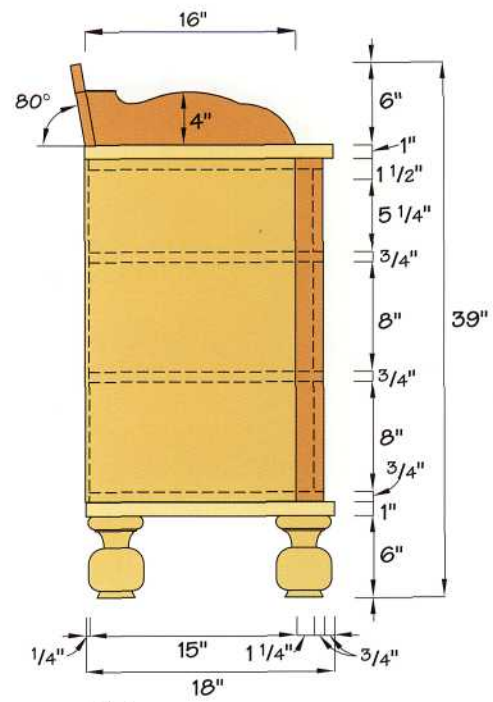

Side

pieces like this, however, would have been painted. I've chosen a scrubbed finish, a look I've seen often on such pieces.

Before the advent of hot and cold running water, washstands like this one would have been an essential part of most early and Victorian American bedroom suites. Towels, washcloths and other linens would have been kept in the drawers while the galleried top would have been home to a large ceramic bowl and water jug. It's a look that's often duplicated to good effect today. This washstand is a faithful copy of the one I found on Jekyll Island. I've searched the books but have not been

able to find anything quite like it. In other words, it seems to be unique.

## CONSTRUCTION OUTLINE

At first glance this is a simple piece, but first glances can often be misleading. To make it you will need to use almost every tool in the shop. When it's finished it will provide you with a unique piece, as well as a real sense of achievement.

Basically, this is a small chest of drawers with turned feet, a nicely shaped gallery and rounded quarter pilasters. The web frames are offset to accommodate the pilaster and attached to the sides with glue and biscuits (dowels would work just as well). The top is made from furniture-grade pine a full 1" thick. The kicker is also a solid piece of stock, nominally 1" thick, upon which the carcass sits. There were no dust panels in the original. The drawers were constructed using lap joints, but, as I felt this was a quality piece, I've taken a liberty and used dovetails. The feet are glued and doweled to the kicker.

There are a couple of tricky areas: the pilasters and the construction of the carcass.

The pilasters are made from two pieces of stock, 25" long X 2" wide X 2" thick. The trick here is how to achieve the quarter-round cross-section. I did it by taking pieces of stock 36 1/2" long X 4" wide X 2" thick and gluing them together—only the first six inches at either end—to make a piece 4" X 4". I then placed the piece in the lathe and turned off the corners to give me what was essentially an eight-sided piece—four flats and four rounded corners. At that point I removed the stock from the lathe and cut off the first six inches at either end, thus the middle section split into two halves. From there it was simply a matter of cutting one of the two halves down the middle to give me the pilasters. The two six-inch 4" X 4" sections? These I turned on the lathe to make two of the four required feet.

The carcass itself is fairly simple to construct; just take care that the offset web frames are accurately measured, made and dadoed into the sides. **Note:** One web frame is 3/4" narrower than the other three. Attaching the pilasters and fillers to the carcass, however, needs special attention. First you'll glue and screw the spacers, edge on, to the carcass (see top photo page 80), then glue and screw the pilasters to the spacers (see bottom photo page 80). Quite simple really.

The gallery or splash-back, as it's often called, is cut from furniture-grade pine, a full 1" thick, and angled to slope away at 6°. The ends of the galleries are lap-jointed and secured together with glue and cut-steel masonry nails for authenticity. The hardware, which is also faith-

ful to the original washstand, was bought from the Woodworker's Store.

## BUILDING THE WASHSTAND

**STEP 1.** Cut and shape the pilasters (see Shop Tip below).

**STEP 2.** Cut the rest of the required pieces to size.

**STEP 3.** Run all the edges through the jointer.

**STEP 4.** Build the boards that will make the top, kicker (base) and two sides.

**STEP 5.** Build the four web frames as laid out in the drawing. Be careful to make one 3/4" narrower than the other three; this one will go at the top of the carcass. Also, be careful to make the offsets accurately as laid out in the drawing.

**STEP 6.** Take the two pieces of stock that will make the sides and cut rabbets 3/4" wide x 1/4" deep at the top and bottom edges to take the top and bottom web frames. Next, cut a rabbet down one long edge of each side 1/4" deep to receive the back—make sure you have a left and right side.

### SHOP TIP

#### Turning Pilasters



The pilasters are an important feature of this old washstand. You might be tempted to leave them out.

Don't. If you have a lathe they are quite simple and fun to make. To make your pilasters you'll need two pieces of stock 36 1/2" X 4" X 2". Apply glue to the first and last six inches of both pieces, put them together, clamp and leave overnight to cure. Find the center at each end and place the piece in the lathe. Turn the piece to round over the corners only leaving flats that measure roughly 1 1/2" across. While the piece is still in the lathe, sand the rounded corners smooth. Remove the piece from the lathe and cut off the first six inches at both ends; this will cause the center to fall apart into two sections, each with two 3/4" flats and a single 1 1/2" flat. On your table saw, split one of the pieces down the middle. This will give you two pilasters. The two 6" sections can be turned into feet.



Glue, assemble and clamp the carcass. Note how the front center clamp is set at an angle to pull the structure square.

**STEP 11.** Cut the biscuit slots to the pilasters and side panels

**STEP 12.** Glue, biscuit and clamp the pilasters to the side panels and screw the spacers to the pilasters

**STEP 13.** Set the piece of stock to be used for the top trim in place against the narrower web frame and mark for biscuits.

**STEP 14.** Cut the biscuit slots, then glue and clamp it in place.

**STEP 15.** Build the drawer guide by gluing and clamping the 3/4" X 3/4" facing strip to the end grain of the piece that measures 15 3/4 X 6 3/4".

**STEP 16.** Glue and screw the drawer partition in place as laid out in the drawing and top photo page 82. You can screw downward through the upper web and upward through the one below. The partition will also double as the two center drawer guides.

**STEP 17.** Build the drawer guides

**STEP 18.** Glue and screw the drawer guides to the carcass.

**STEP 19.** Turn the feet to the dimensions shown in the drawing.

**STEP 20.** Bore a 3/4" hole, 1" deep, in the top center of each foot to take the dowel that will secure the foot in place on the bottom of the washstand.

**STEP 21.** Using a 1/2" bit in your router, round over the front and side edges of the two boards that will be the top and kicker.

**STEP 22.** Bore four 3/4" holes at each corner of the kicker as laid out in the drawing.

**STEP 23.** Using one of the new polyurethane glues and four pieces of 3/4" x 1 3/4" dowel, assemble the feet to the kicker. Clamp and set aside overnight to fully cure.

**STEP 24.** Remove the excess glue from around the feet.

**STEP 25.** Take the three pieces that will make the gallery and cut one end of both of the short sections and both ends of the long piece to an angle of 10° as laid out in the drawing.

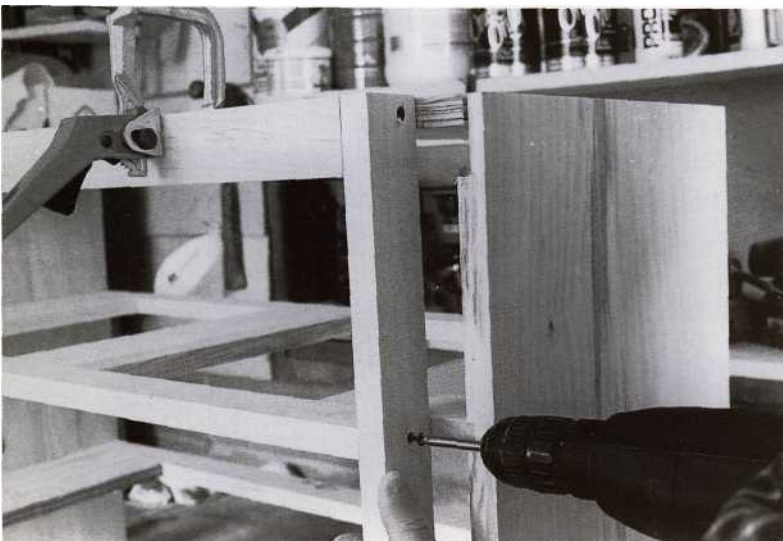

Glue and clamp the trim piece in place on the upper web frame, then fasten the two spacers in place on the web offsets using no. 6 screws.

**STEP 7.** Cut dados in the two side pieces as laid out in the drawing 3/4" wide x 1/4" deep to take the two center web frames.

**STEP 8.** Glue, assemble and clamp the four web frames to the two ends—make sure the narrower web is at the top. Square the structure, then set it aside to cure overnight.

**STEP 9.** Glue and screw the spacers to the webs as you see in photo above.

**STEP 10.** Set the pilasters in place between the spacers and the sides and mark them and the sides for biscuit slots.

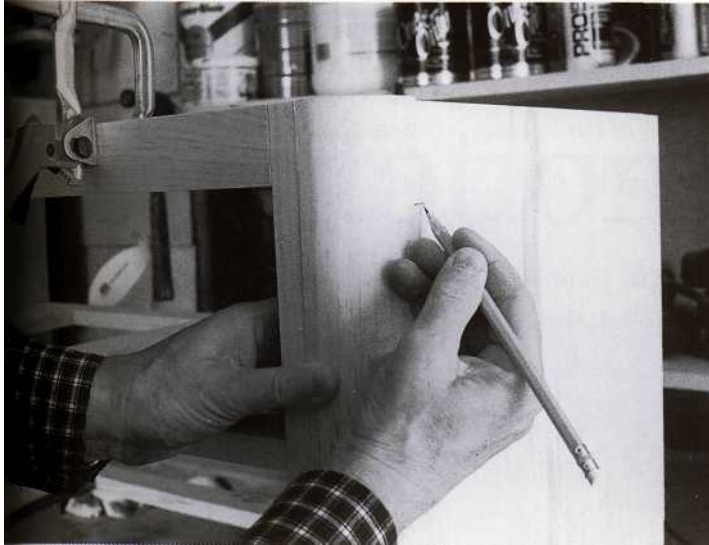

Once the spacers are securely fastened to the carcass, set the pilasters in place and mark them, one side only, and the carcass for biscuit slots.

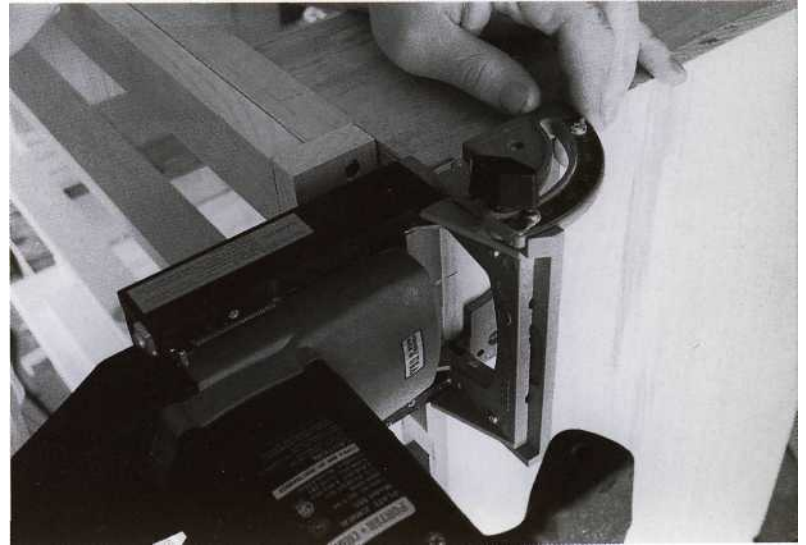

Cut the biscuit slots to the pilasters and side panels



Take extra care to ensure the plate jointer is square to the work when milling the biscuit slots to the pilasters.

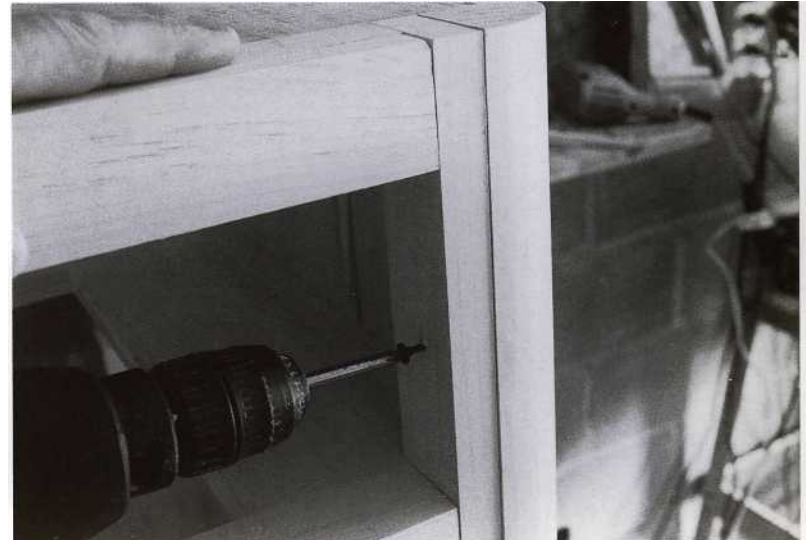

Glue the pilasters in place to the sides of the carcass and, from the inside, using glue and no. 6 screws, secure the pilasters to the spacers already screwed in place.

**STEP 26.** Using either your jointer or table saw, cut the bottom edges of all three pieces to 10° to give the gallery the desired tilt. Make sure you have a left and right section with the angle at the back.

**STEP 27.** Using the scale drawings, cut the details to the upper edges of the three gallery sections. The angle should be at the back of both end sections.

**STEP 28.** Cut rabbets 3/8" deep X 3/4" wide to the ends of the back section of the gallery as you see in the drawing.

**STEP 29.** Glue, nail with cut-steel nails and clamp the side of the gallery to the back (make sure the assembly is square), and set aside overnight to fully cure.

**STEP 30.** From the inside, screw the kicker (base) to the lower web frame of the carcass. Elongate the holes in the carcass and use small washers under the heads of the screws to allow for movement in the kicker.

**STEP 31.** Set the gallery in position on the top and mark the outline lightly with a pencil.

**STEP 32.** Remove the gallery from the top and, using the pencil lines as a guide, bore pilot holes through the top at an angle of 10° to line up with the angle of the tilted gallery.

**STEP 33.** Replace the gallery and secure it in place with screws from the underside.

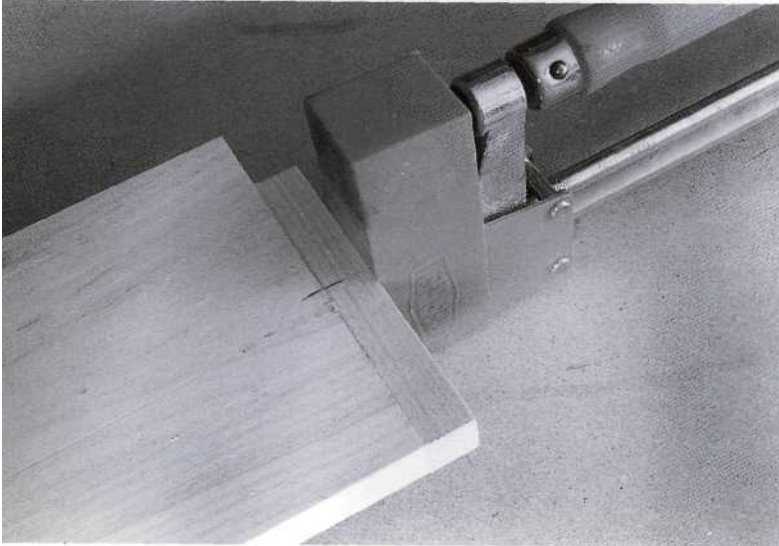

Using a #20 biscuit, fasten the face piece to the front edge of the drawer divider; note the offset.



Use 3/4" dowel and one of the new polyurethane glues to fasten the feet to the kicker.

**STEP 34.** Set the top in place on the carcass and secure with screws from the underside of the top web frame. Elongate the holes and put small washers under the heads of the screws to allow the top room to breathe.

**STEP 35.** Set the back in place inside the rabbets and secure in place with a few brads.

**STEP 36.** To build the drawers follow the procedure as laid out in the Shop

**STEP 37.** Go to finishing.

## FINISHING

I chose a scrubbed pine look for this piece (see chapter three). First you'll need to finish sand the entire piece, then do a little light distressing and finally apply some stain. I used Minwax's Golden Pecan. It gives the pine a delicate patina that shows through the polyurethane/paint solution quite nicely for a really authentic look. When you apply the finish, simply wipe it on and then wipe it off again, leaving only the barest film of pigment over the stain.

### SHOP TIP

## Making Drawer Guides



I make almost all of my drawer guides by taking two pieces of stock of the appropriate length and gluing and screwing them together (see the drawing). The guide piece should be made from a stock  $\frac{3}{4}$ "  $\times$  1" and the support from a section  $\frac{3}{4}$ "  $\times$  2"—sometimes it will need to be wider. Glue the edge of the guide section, assemble it to the support section and secure the resulting assembly with a couple of screws.

# If You Enjoyed This Plan You'll Loved The Full Plan On Teds Woodworking

[Want to get complete plan for this project.](#)

You'll get:

- All-inclusive Blueprints & Plans
- Step-By-Step Photos Detailing Every Step Along The Way
- Illustrated Drawing and Sketches
- Metric and Imperial Measurements
- Complete “Easy-To-Follow” instruction
- Insider tips, tricks, tactics and techniques that professionals use so you can cut corners, and get the job done faster
- 16,000 More Woodworking Plans

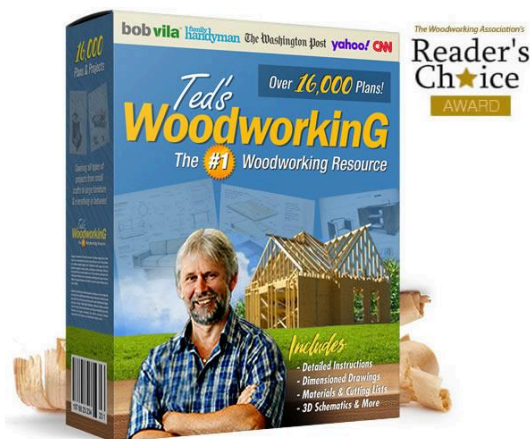

[Order TedsWoodworking today](#) and get full access to all the details of this plan PLUS 16,000 step-by-step woodworking plans

