



# PE Electrical: Power

## 25 Practice Problems & Solutions

### FREE BONUS



**Problem 1.** A circuit consists of a pure resistance connected in series with an unknown impedance. When the circuit is connected to a 480 V source, the pure resistance draws 12.5 kW and the unknown impedance draws 50 kW with a 0.8 power factor. The power factor of the overall circuit is, most nearly:

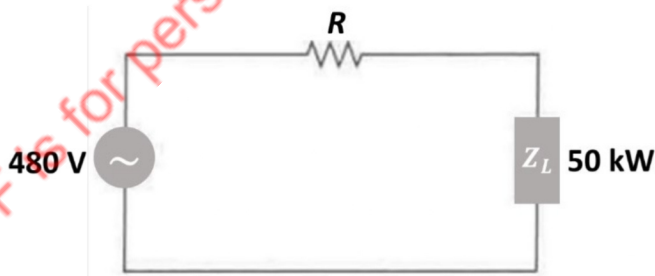

- (A) 0.50
- (B) 0.80
- (C) 0.86
- (D) 0.92

**Problem 2.** When the Wheatstone bridge illustrated below is used to find the resistance value of  $R_x$ , the galvanometer  $G$  displays zero current when  $R_1 = 70 \Omega$ ,  $R_2 = 35 \Omega$ , and  $R_3 = 100 \Omega$ . If  $R_3$  is known with  $\pm 10\%$  tolerance on its nominal value of  $100 \Omega$ , what is the range of  $R_x$  in ohms?

- (A) [45, 50]
- (B) [45, 55]
- (C) [50, 55]
- (D) [50, 65]

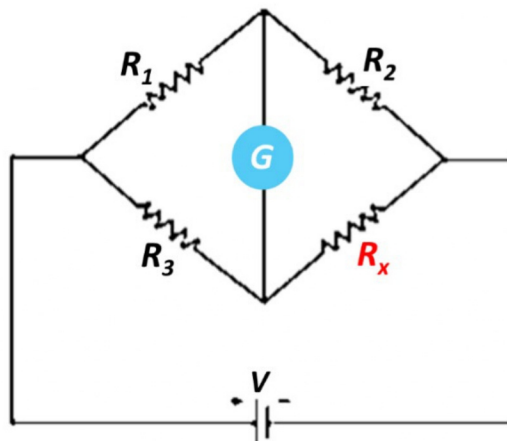

**Problem 3.** A composite parallel plate capacitor is made up of two different dielectrics with different thicknesses  $t_1$  and  $t_2$  as shown in the figure. The two different dielectric materials are separated by a conducting foil  $F$ . The voltage (V) in the conducting foil is, most nearly:

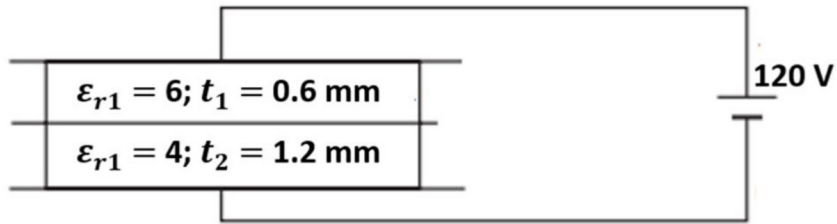

- (A) 30
- (B) 45
- (C) 60
- (D) 90

**Problem 4.** A circular turn of radius 2 m revolves at 30 rpm about its diameter aligned with the x-axis, as shown in the figure. The value of vacuum permeability may be taken as  $4\pi \times 10^{-7}$  H/m. If a uniform magnetic field  $\mathbf{H} = 5 \times 10^7 \vec{k}$  A/m is applied over the region in which the turn is located, the peak value (V) of the induced voltage is, most nearly:

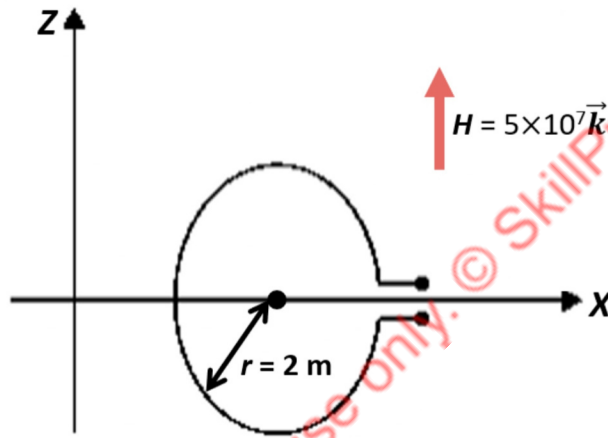

- (A) 1000
- (B) 1500
- (C) 2000
- (D) 2500

**Problem 5.** A single core cable is 5 km long and has an insulation resistance of 0.62 MΩ. The core diameter is 35 mm and the diameter of the cable including insulation is 75 mm. The resistivity of the insulating material ( $\Omega \cdot m$ ) is, most nearly:

- (A)  $2.5 \times 10^{10}$
- (B)  $6 \times 10^{10}$
- (C)  $8.5 \times 10^{10}$
- (D)  $2 \times 10^{11}$

**Problem 6.** A single-phase transmission line having a copper conductor of cross-section equal to  $0.9 \text{ cm}^2$  is designed to deliver a power of 400 kW at unity power factor and voltage equal to 3200 V. The efficiency of the transmission line is 64% and the specific resistance is  $2.0 \mu\Omega/\text{cm}$ . The maximum length of the line (km) is, most nearly:

- (A) 10.8
- (B) 16.2
- (C) 32.4
- (D) 41.2

**Problem 7.** When is maximum power transferred from a generator to the load through a transmission line?

- (A) When the reflection coefficient equals unity.
- (B) When the standing wave ratio equals zero.
- (C) When the load impedance is equal to the characteristic impedance of the line.
- (D) When corona losses are maximum.

**Problem 8.** Two ideal transmission lines with parameter sets  $(A_1, B_1, C_1, D_1)$  and  $(A_2, B_2, C_2, D_2)$  are connected in parallel. Which of the following alternatives contains the correct parameter  $A$  of this transmission line combination?

- (A)  $\frac{(A_1 B_2 + A_2 B_1)}{(B_1 + B_2)}$   
 (B)  $\frac{(A_1 B_1 + A_2 B_2)}{(B_1 + B_2)}$   
 (C)  $\frac{(B_1 + B_2)}{(A_1 B_2 + A_2 B_1)}$   
 (D)  $\frac{(B_1 + B_2)}{(A_1 B_1 + A_2 B_2)}$

**Problem 9.** A 810-kV transmission line has per-phase line inductance equal to 1.2 mH/km and per-phase line capacitance of 10.8 nF/km. Ignoring the length of the line, its ideal power transfer capability (MW) is, most nearly:

- (A) 1750  
 (B) 1980  
 (C) 2100  
 (D) 2230

**Problem 10.** The per-unit impedance in a power system network is  $X_1$ . If the apparent power is tripled and the applied voltage is doubled, the new p.u. impedance  $X_2$  becomes:

- (A)  $0.5X_1$   
 (B)  $0.75X_1$   
 (C)  $X_1$   
 (D)  $1.25X_1$

**Problem 11.** The  $A$ ,  $B$ ,  $C$  and  $D$  constants of a 220-kV line are  $A = D = 0.92\angle 1^\circ$ ,  $B = 144\angle 74^\circ$ , and  $C = 0.0012\angle 85^\circ$ . If sending end voltage of the line for a given load delivered at nominal voltage is 250 kV, then the percent voltage regulation of the line is, most nearly:

- (A) 16.5  
 (B) 20.0  
 (C) 23.5  
 (D) 27.0

**Problem 12.** The generalized circuit constants of a three-phase, 220-kV rated voltage, medium length transmission line are specified below.

$$A = D = 0.944 + j0.018 = 0.944\angle 1.09^\circ$$

$$B = 32.1 + j140 = 143.6\angle 77.4^\circ$$

$$C = (-5.16 + j889) \times 10^{-6} \Omega$$

If the load at the receiving end is 60 MW at 220 kV with a power factor of 0.85 lagging, then the magnitude of line-to-line send end voltage (kV) is, most nearly:

- (A) 226  
 (B) 243  
 (C) 270  
 (D) 281

**Problem 13.** The figure shows a 410-kV (line-to-line voltage) transmission line linking two systems. The theoretical maximum power that can be transferred from System A to System B is 5000 MW, which occurs when the power angle  $\delta = 90^\circ$ . The line current is then proportional to  $(V_A - V_B)$ . The reactive power losses (Mvar) in the transmission line during this transfer would be, most nearly:

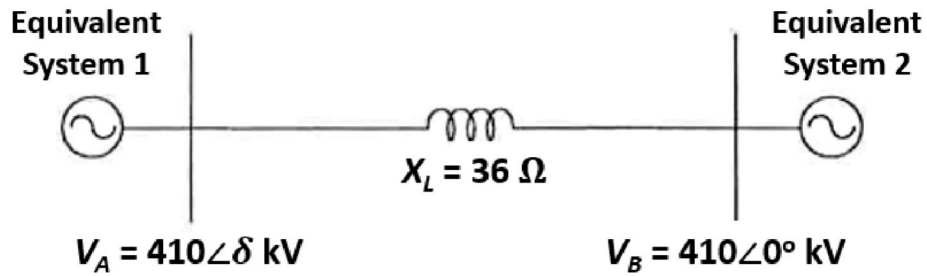

- (A) 7100
- (B) 8200
- (C) 9400
- (D) 11,000

**Problem 14.** At an industrial sub-station with a 5 MW load, a capacitor of 2.5 Mvar is installed to maintain the load power factor at 0.96 lagging. If the capacitor goes out of service, the load power factor becomes, most nearly:

- (A) 0.78 lag
- (B) 0.83 lag
- (C) 0.88 lag
- (D) 0.93 lag

**Problem 15.** A 3-phase, 220 kV, 50 Hz transmission line consists of a 3-cm radius conductor spaced 4.8 meters apart in an equilateral triangle arrangement. The surrounding temperature is 40°C and the atmospheric pressure is 760 mmHg. Take 120 kV as the critical disruptive voltage. The corona loss (kW/km) per kilometer of line in all three phases is, most nearly:

- (A) 1.10
- (B) 2.20
- (C) 2.75
- (D) 3.15

**Problem 16.** The bus admittance matrix of a three-bus, three-line system is shown below.

$$\mathbf{Y} = j \begin{bmatrix} -14 & 11 & 6 \\ 11 & -18 & 11 \\ 6 & 11 & -14 \end{bmatrix}$$

If each transmission line between the two buses is represented by an equivalent  $\pi$ -network, the magnitude of the shunt susceptance of the line connecting buses 1 and 2 is

- (A) 1
- (B) 2
- (C) 3
- (D) 4

**Problem 17.** The bus admittance matrix for a power system network is given below.

$$\mathbf{Y} = j \begin{bmatrix} -39.9 & 20 & 20 \\ 20 & -39.9 & 20 \\ 20 & 20 & -39.9 \end{bmatrix} \text{ pu}$$

Part of the system consists of a transmission line, connected between buses 1 and 3, which is represented by the following circuit:

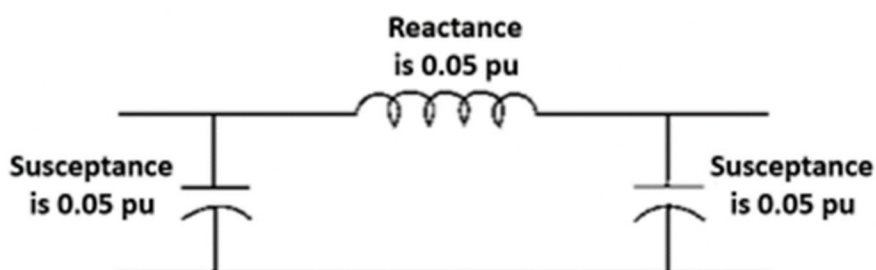

If this transmission line is removed from service, what is the modified bus admittance matrix?

$$(A) \begin{bmatrix} -j19.9 & j20 & 0 \\ j20 & -j39.9 & j20 \\ 0 & j20 & -j19.9 \end{bmatrix} \text{ pu} \quad (B) \begin{bmatrix} -j39.95 & j20 & 0 \\ j20 & -j39.9 & j20 \\ 0 & j20 & -j39.95 \end{bmatrix} \text{ pu}$$

$$(C) \begin{bmatrix} -j19.95 & j20 & 0 \\ j20 & -j39.9 & j20 \\ 0 & j20 & -j19.95 \end{bmatrix} \text{ pu} \quad (D) \begin{bmatrix} -j19.95 & j20 & j20 \\ j20 & -j39.9 & j20 \\ j20 & j20 & -j19.95 \end{bmatrix} \text{ pu}$$

**Problem 18.** For the single-line diagram shown, buses 1 to 4 are described by the following table. The acceleration factor is 1.5. Using the Gauss-Seidel method, the voltage phasor at bus 2 obtained in the first iteration is, most nearly:

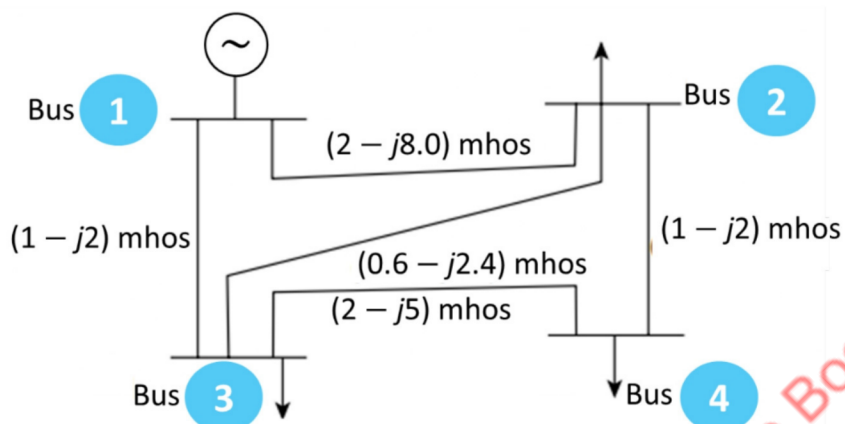

Bus No.	$P$ Real power (pu)	$Q$ Reactive power (pu)	$V$ Bus voltage (pu)
1	—	—	1.05
2	0.4	0.2	1.0
3	0.3	0.1	1.0
4	0.2	0.1	1.0

- (A)  $1.0 \angle -6.84^\circ$   
 (B)  $1.0 \angle -4.12^\circ$   
 (C)  $1.0 \angle -1.65^\circ$   
 (D)  $1.0 \angle -0.82^\circ$

**Problem 19.** An IDMT overcurrent relay has a current setting of 125% and a time multiplier setting of 0.75. The relay's primary is connected to the secondary of a current transformer of ratio 400/5. The time-current characteristic of the relay is shown to the side. The time of operation (secs) if the circuit carries a fault current of 5000 A is, most nearly:

- (A) 1.0  
 (B) 1.5  
 (C) 2.0  
 (D) 2.5

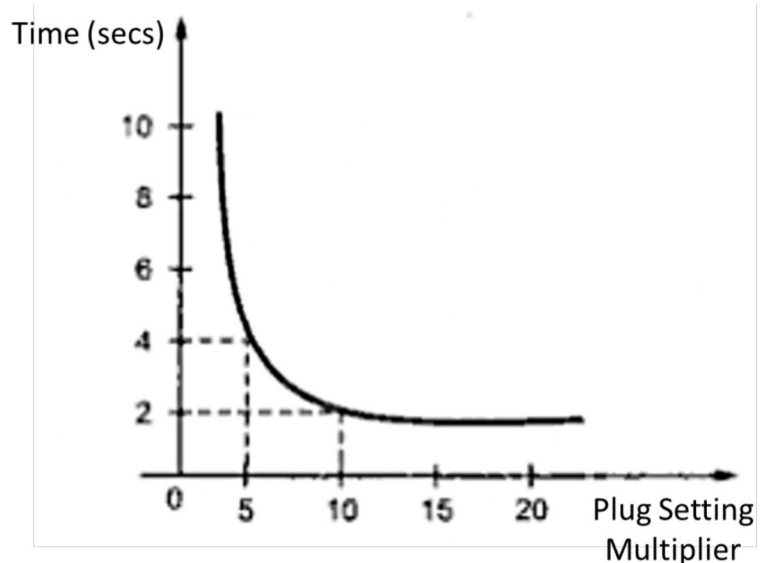

**Problem 20.** A 3-phase, 60-Hz induction motor has a nameplate speed of 1100 rpm. This motor has how many poles?

- (A) 2.0  
 (B) 4.0  
 (C) 4.5  
 (D) 6.0

**Problem 21.** A 60-Hz generating unit has H-constant equal to 2.2 MJ/MVA. The machine is initially operating in steady state at synchronous speed and producing 1 pu of real power. The initial value of the rotor angle  $\delta$  is  $6^\circ$ . Suddenly, a bolted three-phase-to-ground short circuit fault occurs at the terminal of the generator. Assuming the input mechanical power must remain at 1 pu, the value of  $\delta$  (degrees), 0.04 seconds after the fault, is most nearly:

- (A) 8
- (B) 10
- (C) 12
- (D) 14

**Problem 22.** If the slip in a motor decreases while the torque remains constant, what is the effect on the motor's speed and power?

- (A) Speed increases; power increases
- (B) Speed decreases; power increases
- (C) Speed increases; power decreases
- (D) Speed decreases; power decreases

**Problem 23.** Below we have the power-angle curve  $P_{elec}$  for a synchronous generator initially operating at rotor angle  $\delta_{ini}$ . The horizontal line refers to the mechanical power input  $P_m$  to the generator. Suddenly, a three-phase fault causes the rotor angle to accelerate from  $\delta_{ini}$  to a new value  $\delta_1$ . Which of the colored areas is considered directly proportional to the kinetic energy added to the machine's rotor during the fault?

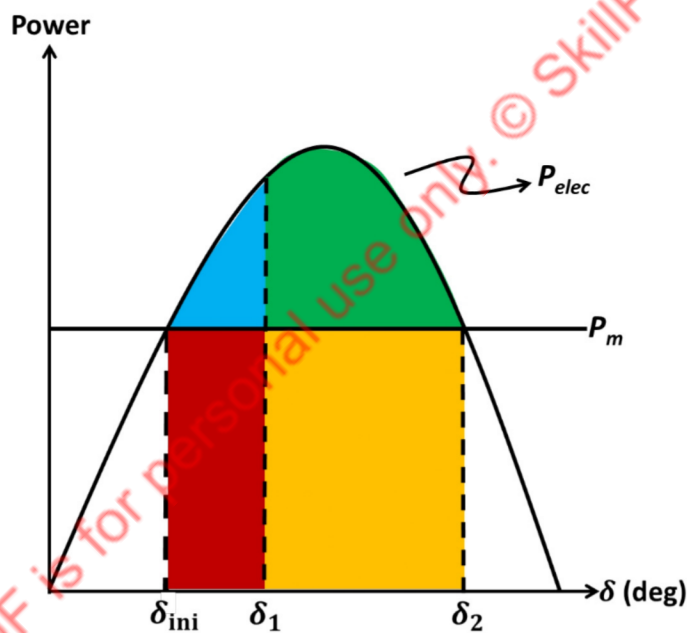

- (A) The blue area.
- (B) The red area.
- (C) The green area.
- (D) The yellow area.

**Problem 24.** A load center is equidistant from two thermal generating stations  $\Gamma_1$  and  $\Gamma_2$ , as illustrated below. The fuel cost characteristics of the two generating stations are given by the quadratic expressions

$$F_1(P_1) = a + bP_1 + cP_1^2 \text{ (dollars per hour)}$$

$$F_2(P_2) = a + bP_2 + 3cP_2^2 \text{ (dollars per hour)}$$

where  $P_1$  and  $P_2$  are the powers (MW) supplied by generators 1 and 2, respectively. Ignore any losses. For most economic generation, the values of  $P_1$  and  $P_2$  for a combined power supply equal to 500 MW are, respectively:

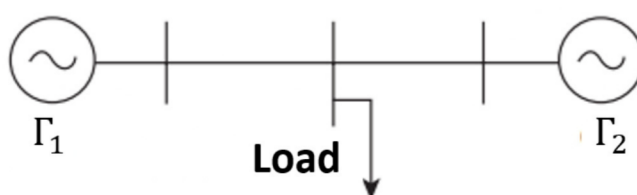

- (A) 125, 375
- (B) 200, 300
- (C) 300, 200
- (D) 375, 125

**Problem 25.** Incremental fuel costs (in some appropriate unit) for a power plant consisting of three generating units are expressed as

$$IC_1 = 20 + 0.4P_1$$

$$IC_2 = 30 + 0.3P_2$$

$$IC_3 = 30$$

where  $P_i$  is the power in MW generated by unit  $i$ , with  $i = 1, 2, 3$ .

Assume that all three units are operating all the time. The minimum and maximum loads on each unit are 60 MW and 360 MW, respectively. If the plant is operating on economic load dispatch to supply a total power demand of 840 MW, which of the following alternatives lists the power values generated by each unit?

(A)  $P_1 = 260$  MW,  $P_2 = 220$  MW,  $P_3 = 360$  MW

(B)  $P_1 = 220$  MW,  $P_2 = 260$  MW,  $P_3 = 360$  MW

(C)  $P_1 = 230$  MW,  $P_2 = 250$  MW,  $P_3 = 360$  MW

(D)  $P_1 = 225$  MW,  $P_2 = 265$  MW,  $P_3 = 350$  MW

### ► ANSWER KEY

Problem	Answer	Problem	Answer
1	C	14	A
2	B	15	B
3	D	16	C
4	D	17	C
5	A	18	B
6	C	19	B
7	C	20	D
8	A	21	B
9	B	22	A
10	B	23	B
11	C	24	D
12	B	25	B
13	C		

### ► SOLUTIONS

1 → C

The power triangle for the unknown impedance is shown below.

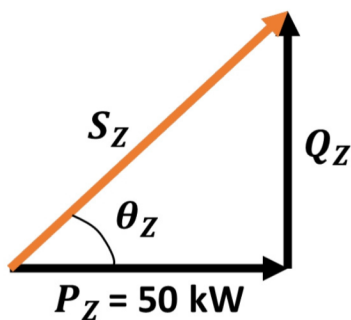

Noting that  $\theta_Z = \arccos(pf) = \arccos(0.8) = 36.9^\circ$ , the reactive power  $Q_Z$  can be determined from the geometry of the triangle:

$$Q_Z = P_Z \tan \theta_Z = 50 \times \tan(36.9^\circ) = 37.5 \text{ kVAR}$$

The power triangle of the overall system is shown next.

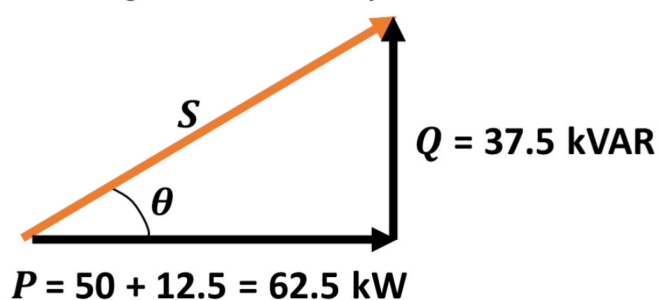

From elementary trigonometry,

$$\theta = \arctan\left(\frac{Q}{P}\right) = \arctan\left(\frac{37.5}{62.5}\right) = 31.0^\circ$$

Finally,

$$\text{Power factor} = \cos \theta = \cos(31.0^\circ) = \boxed{0.857}$$

## 2 → B

Recall that a Wheatstone bridge such as the one we were given is balanced when  $R_1R_x = R_2R_3$ . If resistance  $R_3$  has a tolerance of 10 percent, its value varies from  $90 \Omega$  to  $110 \Omega$ . Substituting  $R_{3,\min}$  into the Wheatstone bridge equation gives

$$R_1R_x = R_2R_{3,\min} \rightarrow R_x = \frac{R_2R_{3,\min}}{R_1}$$

$$\therefore R_x = \frac{35 \times 90}{70} = \underline{45 \Omega}$$

Similarly, if  $R_{3,\max} = 110 \Omega$ ,

$$R_x = \frac{35 \times 110}{70} = \underline{55 \Omega}$$

Thus,  $R_x \in [45, 55] \Omega$ .

## 3 → D

The capacitance of either dielectric layer is given by  $C = \epsilon_r \epsilon_0 A/t$ . When two capacitors are connected in series, the charge is the same in each one. Recalling that  $Q = CU$ , we may write

$$\begin{aligned} Q_1 &= Q_2 \rightarrow C_1(120 - U) = C_2U \\ \therefore \frac{\epsilon_{r,1} \cancel{\epsilon_0 A}}{t_1} (120 - U) &= \frac{\epsilon_{r,2} \cancel{\epsilon_0 A}}{t_2} U \\ \therefore \frac{\epsilon_{r,1}}{t_1} (120 - U) &= \frac{\epsilon_{r,2}}{t_2} U \\ \therefore \frac{6}{0.6} (120 - U) &= \frac{4}{1.2} U \\ \therefore \boxed{U = 90 \text{ V}} \end{aligned}$$

## 4 → D

The intensity of the magnetic field is  $\mathbf{B} = \mu_0 \mathbf{H} = (4\pi \times 10^{-7}) \times (5 \times 10^7) = 20\pi \vec{k}$  T. The area of the circular turn that is exposed to the field varies as  $A = \pi r^2 \sin \omega t$ , so the flux  $\phi$  is such that

$$\phi = BA = 20\pi \times \pi r^2 \sin(\omega t) = 20\pi^2 r^2 \sin(\omega t)$$

Differentiating the flux with respect to time gives the induced voltage:

$$\begin{aligned} V &= -\frac{d\phi}{dt} = -20\pi^2 r^2 \times [-\cos(\omega t)\omega] \\ \therefore V &= 20\pi^2 \omega r^2 \cos(\omega t) \end{aligned}$$

The maximum induced voltage occurs when  $\cos(\omega t) = 1$ , therefore

$$\begin{aligned} |V| &= 20\pi^2 \omega r^2 = 20\pi^2 \times \frac{2\pi N}{60} \times r^2 \\ \therefore |V| &= 20\pi^2 \times \frac{2\pi \times 30}{60} \times 2^2 = \boxed{2480 \text{ V}} \end{aligned}$$

## 5 → A

All we have to do is evoke the resistance law

$$R = \frac{\rho}{2\pi \ell} \ln\left(\frac{r_2}{r_1}\right)$$

and solve for the resistivity  $\rho$ , giving

$$\rho = \frac{2\pi \ell R}{\ln(r_2/r_1)}$$

$$\therefore \rho = \frac{2\pi \times 5000 \times (0.62 \times 10^6)}{\ln[(75/2)/(35/2)]} = \boxed{2.56 \times 10^{10} \Omega \cdot \text{m}}$$

### 6 → C

As stated, the line supplies a power of 400 kW. For a transmission efficiency of 64%, the sending-end power becomes  $400/0.64 = 625$  kW. We also need the line losses, namely  $625 - 400 = 225$  kW, and the line current, namely

$$I = \frac{400,000}{3200} = 125 \text{ A}$$

The resistance of the line is then

$$\text{Line losses} = 2RI^2 \rightarrow R = \frac{\text{Line losses}}{2I^2}$$

$$\therefore R = \frac{225,000}{2 \times 125^2} = 7.2 \Omega$$

It remains to compute the line length  $L$  using Ohm's law:

$$R = \frac{\rho L}{A} \rightarrow L_{\max} = \frac{RA}{\rho}$$

$$\therefore L_{\max} = \frac{7.2 \times 0.9}{2.0 \times 10^{-6}} = 3.24 \times 10^6 \text{ cm} = \boxed{32.4 \text{ km}}$$

### 7 → C

When maximum power is transferred to the load, the incident wave is entirely absorbed by the load and there is no reflected power. This happens only when the characteristic impedance of the line,  $Z_0$ , and the load impedance,  $Z_L$ , are the same. Accordingly, option C is true.

The reflection coefficient  $\Gamma$  is given by  $(Z_L - Z_0)/(Z_L + Z_0)$ . When  $Z_L$  and  $Z_0$  are equal, the reflection coefficient is zero. Thus, option A is false.

The standing wave ratio is equal to  $(1 + |\Gamma|)/(1 - |\Gamma|)$ . When the reflection coefficient is zero, the standing wave ratio is one. Thus, option B is false.

It goes without saying that increasing corona losses does not favor power supply through a transmission line. Thus, option D is false.

### 8 → A

It can be shown that for a parallel combination of two ideal transmission lines, the receiving-end voltages, the sending-end voltages, and the corresponding currents are related as

$$(B_2 + B_1)V_S = (A_1B_2 + A_2B_1)V_R + B_1B_2(I_{R1} + I_{R2})$$

This can be restated as

$$V_S = \frac{(A_1B_2 + A_2B_1)}{B_1 + B_2}V_R + \frac{B_1B_2}{B_1 + B_2}I_R$$

so that, comparing with the corresponding relationship for a single line,

$$V_S = AV_R + BI_R$$

we conclude that

$$\underline{A_{\text{comb}}} = \frac{A_1B_2 + A_2B_1}{B_1 + B_2} ; \underline{B_{\text{comb}}} = \frac{B_1B_2}{B_1 + B_2}$$

### 9 → B

The surge impedance is such that

$$Z = \sqrt{\frac{L}{C}} = \sqrt{\frac{1.2 \times 10^{-3}}{10.8 \times 10^{-9}}} = 333 \Omega$$

and the ideal power transfer equals

$$\Pi = \frac{V^2}{Z} = \frac{810^2}{333} = \boxed{1970 \text{ MW}}$$

**10 → B**

Noting that

$$X_1 = \frac{(MVA)_1}{(kV_1)^2}$$

we may write

$$X_2 = \frac{(MVA)_2}{(kV_2)^2} = \frac{3(MVA)_1}{[k \times (2V_1)]^2} = \frac{3(MVA)_1}{4 \underbrace{(kV_1)^2}_{=X_1}}$$

$$\therefore \boxed{X_2 = 0.75X_1}$$

**11 → C**

By definition, percent voltage regulation is given by

$$\% \text{ Volt. Reg.} = \frac{V_{r(\text{no load})} - V_{r(\text{full load})}}{V_{r(\text{full load})}} \times 100\%$$

Here,  $V_{r(\text{no load})} = V_s/|A| = 250/0.92 = 271.7 \text{ V}$  and  $V_{r(\text{full load})} = 220 \text{ kV}$ , giving

$$\% \text{ Volt. Reg.} = \frac{271.7 - 220}{220} \times 100\% = \boxed{23.5\%}$$

**12 → B**

In view of the transmission line parameters and given data, we have  $P_R = 60 \text{ MW}$ ,  $V_r = 220 \text{ kV}$ ,  $\alpha = 1.09^\circ$ ,  $\beta = 77.4^\circ$ , and  $p_f = 0.85$  lag. We know that the rated power can be expressed as

$$P_r = \frac{|V_s||V_r|}{|B|} \cos(\beta - \delta) - \frac{|A||V_r|^2}{|B|} \cos(\beta - \alpha)$$

$$\therefore P_r = \frac{|V_s| \times 220}{143.6} \times \cos(77.4^\circ - \delta) - \frac{0.944 \times 220^2}{143.6} \cos(77.4^\circ - 1.09^\circ) = 60$$

$$\therefore P_r = 1.53|V_s| \cos(77.4^\circ - \delta) - 75.3 = 60$$

$$\therefore |V_s| \cos(77.4^\circ - \delta) = 88.43 \quad (\text{I})$$

For reactive power, in turn, we write

$$Q_r = P_R \tan \phi = P_R \tan(\cos^{-1} \phi)$$

$$\therefore Q_r = P_R \tan \phi = 60 \tan(\cos^{-1} 0.85) = 37.2 \text{ MW}$$

$$Q_r = \frac{|V_s||V_r|}{|B|} \sin(\beta - \delta) - \frac{|A||V_r|^2}{|B|} \sin(\beta - \alpha) = 37.2$$

$$\therefore Q_r = \frac{|V_s| \times 220}{143.6} \sin(77.4^\circ - \delta) - \frac{0.944 \times 220^2}{143.6} \sin(77.4^\circ - 1.09^\circ) = 37.2$$

$$\therefore Q_r = 1.53|V_s| \sin(77.4^\circ - \delta) - 309.1 = 37.2$$

$$\therefore |V_s| \sin(77.4^\circ - \delta) = 226.34 \quad (\text{II})$$

Combining (I) and (II), we get the absolute value of the sending-end voltage:

$$|V_s| = \sqrt{88.43^2 + 226.34^2} = \boxed{243.0 \text{ kV}}$$

**13 → C**

We first compute the reactive current:

$$I_{\text{Transf}} = \frac{410 \angle 90^\circ - 410 \angle 0^\circ}{\sqrt{3} \times (36 \angle 90^\circ)} = 6.58 + j6.58 \text{ A}$$

or,

$$I_{\text{Transf}} = 9.31 \angle 45^\circ \text{ A}$$

The reactive power losses are then

$$\text{VAR} = 3 \times 9.31^2 \times 36 = \boxed{9360 \text{ Mvar}}$$

**14 → A**

We have  $P_L = 5$  MW,  $Q_C = 2.5$  Mvar, and an initial power factor equal to 0.96 lagging, we have

$$\cos \phi = 0.96 \rightarrow \phi = \cos^{-1} 0.96 = 16.3^\circ$$

or

$$\tan \phi = \tan 16.3^\circ = 0.292$$

so that

$$\tan \phi = \frac{Q_L - Q_C}{P_L} = 0.292$$

$$\therefore \frac{Q_L - 2.5}{5} = 0.292$$

$$\therefore Q_L = 3.96 \text{ Mvar}$$

$$\therefore \phi = \tan^{-1} \left( \frac{Q_L}{P_L} \right) = \tan^{-1} \left( \frac{3.96}{5} \right) = 38.4^\circ$$

$$\therefore \cos(38.4^\circ) = \boxed{0.784 \text{ lag}}$$

**15 → B**

The corona loss is given by Peek's correlation,

$$P = 241 \times 10^{-5} \left( \frac{f + 25}{\delta} \right) \sqrt{\frac{r}{d}} (V - V_c)^2$$

where  $f$  is the voltage supply frequency,  $\delta$  is the air density correction factor,  $r$  is the conductor radius,  $d$  is the distance between two adjacent conductors,  $V$  is the operating voltage, and  $V_c$  is the critical disruptive voltage. The correction factor  $\delta$  is a function of atmospheric pressure (in cmHg) and temperature ( $^\circ\text{C}$ ), namely

$$\delta = \frac{3.93 p_{\text{atm}}}{273 + T} = \frac{3.93 \times 76}{273 + 40} = 0.954$$

The voltage supply per phase is  $V = 220/\sqrt{3} = 127$  V. Substituting these and other variables into the equation for  $P$  brings to

$$P = 241 \times 10^{-5} \times \left( \frac{50 + 25}{0.954} \right) \times \sqrt{\frac{3}{480}} \times (127 - 120)^2 = 0.734 \text{ kW/km/phase}$$

Accounting for the three phases, we obtain  $P_t = 3 \times 0.734 = 2.20$  kW/km.

**16 → C**

Let  $Y_{\text{line}}$  denote the shunt susceptance we aim for. With reference to the bus admittance matrix, we have

$$(Y_{12} + Y_{\text{line}}) + Y_{11} + Y_{13} = 0 \rightarrow (j11 + Y_{\text{line}}) - j14 + j6 = 0$$

$$\therefore Y_{\text{line}} = -j3$$

$$\therefore \boxed{|Y_{\text{line}}| = 3}$$

**17 → C**

Initially, we have  $Y_{13} = j20$ . Once the line between (1) and (3) is removed,

$$Y_{13} = 0 \text{ (New value)}$$

$$Y_{11} = -j39.9 \text{ (Old value)}$$

$$Y_{11(\text{new})} = -j39.9 - (-j20) - j0.05 = -j19.95$$

$$Y_{33(\text{new})} = -j39.9 - (-j20) - j0.05 = -j19.95$$

Thus, the updated bus admittance matrix is given in option C.

**18 → B**

Applying the Gauss-Seidel method, we have, for a first iteration,

$$V_2' = \frac{1}{y_{22}} \left[ \frac{P_2 - jQ_2}{V_2^*} - y_{21}V_1^o - y_{23}V_3^o - y_{24}V_4^o \right]$$

$$\therefore V_2' = \frac{1}{3.5 - j10.4} \left[ \begin{array}{l} \frac{-0.4 + j0.2}{1.0} - (-2 + j6) \times 1.05 - (-0.5 + j2.4) \times 1.0 \\ -(-1 + j2) \times 1.0 \end{array} \right]$$

$$\therefore V_2' = 1.0 - j0.0288 \text{ pu}$$

or, in phasor form:

$$\therefore V_2' = 1.0 \angle -1.651^\circ$$

For an acceleration factor equal to 1.5 pu, we ultimately obtain

$$V_{2,\text{acc}}' = 1.0 \angle -1.651^\circ + 1.5(1.0 \angle -1.651^\circ - 1.0 \angle 0)$$

$$\therefore V_{2,\text{acc}}' = 1.0 \angle (-0.0720 \text{ rad})$$

$$\therefore \boxed{V_{2,\text{acc}}' = 1.0 \angle -4.12^\circ}$$

### 19 → B

The fault current observed in the relay coil is

Fault current in relay coil = Actual fault curr. × CT ratio

$$\therefore \text{Fault current in relay coil} = 5000 \times \frac{5}{400} = 62.5 \text{ A}$$

so that, given the rated secondary of CT = 5 A and the current setting = 150%, we obtain the PSM

$$PSM = \frac{62.5}{5 \times 1.25} = 10$$

Entering this PSM value into the graph, we read a time equal to 2 sec. Lastly, we multiply this quantity by the time setting multiplier, which is 0.75, giving

$$\text{Actual operation time} = 2.0 \times 0.75 = \boxed{1.5 \text{ s}}$$

### 20 → D

The synchronous speed, expressed in rpm, is given by

$$\frac{120f}{n_p} = \text{Sync. spd.}$$

where  $f$  is the angular frequency (Hz) and  $n_p$  is the number of poles. An induction motor will slip slightly when operating under load. Accordingly, it will run at a speed slightly less than synchronous. The synchronous speed just above 1100 rpm that corresponds to 60 Hz and an even number of poles is 1200 rpm. The corresponding number of poles is 6.

$$\text{In[419]:= Solve}[120 * 60 / np == 1200, np]$$

$$\text{Out[419]:= } \{ \{ np \rightarrow 6 \} \}$$

### 21 → B

Noting that  $\delta_o = 6^\circ = 0.105 \text{ rad}$ , the equation to use is

$$t_{cr} = \sqrt{\frac{2H(\delta_{cr} - \delta_o)}{\pi f P_m}} = \sqrt{\frac{2 \times 2.2 \times (\delta_{cr} - 0.105)}{\pi \times 60 \times 1.0}} = 0.04 \text{ s}$$

Squaring both sides and solving the equation yields  $\delta_{cr} \approx 0.174 \text{ rad} \approx 9.97^\circ$ .

$$\text{In[562]:= Solve}\left[\sqrt{\frac{2 * 2.2 * (\delta_{cr} - 0.105)}{\text{Pi} * 60 * 1.0}} == 0.04, \delta_{cr}\right]$$

$$\text{Out[562]:= } \{ \{ \delta_{cr} \rightarrow 0.173544 \} \}$$

$$\text{In[563]:= } 0.174 / ^\circ$$

$$\text{Out[563]:= } 9.96947$$

### 22 → A

From the definition of slip,

$$\text{Slip} = \frac{(n_s - n)}{n_s}$$

where  $n_s$  is synchronous speed and  $n$  is motor speed. Solving for  $n$  brings to

$$n = n_s (1 - \text{slip})$$

so we conclude that decreasing slip *increases* the speed of the motor. Now, proceeding similarly with power  $\Pi$ , we have

$$\begin{aligned} \Pi &= T\Omega = T \times \left( \frac{60 \text{ s/min}}{2\pi \text{ rad/rev}} \right) \times n \\ \therefore \Pi &= T \times \left( \frac{60 \text{ s/min}}{2\pi \text{ rad/rev}} \right) \times n_s (1 - \text{slip}) \end{aligned}$$

Decreasing slip causes the rightmost factor in the equation above to increase; accordingly, the power of the motor *increases* as the slip decreases.

### 23 → B

The fault reduces the electrical power  $P_{elec}$  to zero while keeping the mechanical power  $P_m$  constant. As a result, the rotor accelerates with the additional kinetic energy stored in the rotating inertia of the rotor until the fault is cleared at  $\delta_1$  and the additional kinetic energy can be released into the grid. The red area is proportional to the kinetic energy added to the rotor during the fault.

### 24 → D

Needless to say, powers  $P_1$  and  $P_2$  must add up to the desired value of 500 MW:

$$P_1 + P_2 = 500 \quad (\text{I})$$

Also, for economical operation,

$$\begin{aligned} \frac{dF_1}{dP_1} &= \frac{dF_2}{dP_2} \rightarrow b + 2cP_1 = b + 6cP_2 \\ \therefore 2cP_1 &= 6cP_2 \\ \therefore P_1 &= 3P_2 \end{aligned}$$

Substituting into (I),

$$\begin{aligned} P_1 + P_2 &= 500 \rightarrow 4P_2 = 500 \\ \therefore P_2 &= \underline{125 \text{ MW}} \end{aligned}$$

Finally,

$$P_1 = 3 \times 125 = \underline{375 \text{ MW}}$$

### 25 → B

For optimal power generation, the power  $\Pi_3$  generated by plant 3 is fixed at the maximum load, namely 360 MW. Further, we set  $IC_1$  equal to  $IC_2$ , giving

$$\begin{aligned} IC_1 &= IC_2 \rightarrow 20 + 0.4P_1 = 30 + 0.3P_2 \\ \therefore 0.4P_1 - 0.3P_2 &= 10 \quad (\text{I}) \end{aligned}$$

Since the three units must supply a combined power of 720 MW, we also have

$$\begin{aligned} P_1 + P_2 + P_3 &= 840 \\ \therefore P_1 + P_2 + 360 &= 840 \\ \therefore P_1 + P_2 &= 480 \\ \therefore P_2 &= 480 - P_1 \end{aligned}$$

Substituting in (I) brings to

$$\begin{aligned} 0.4P_1 - 0.3 \times (480 - P_1) &= 10 \\ P_1 &= \underline{220 \text{ MW}} \end{aligned}$$

Finally,

$$P_2 = 840 - P_1 - P_3 = 840 - 220 - 360 = \underline{260 \text{ MW}}$$

In summary, the power values supplied by the three units are  $P_1 = 220$  MW,  $P_2 = 260$  MW, and  $P_3 = 360$  MW.